

MFD-Titan

MFD-CP4-CO

MFD-80-...

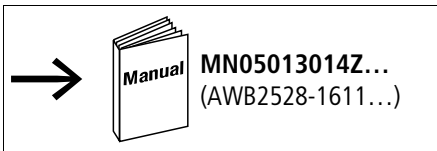

-25...+55 °C

-13...+131 °F

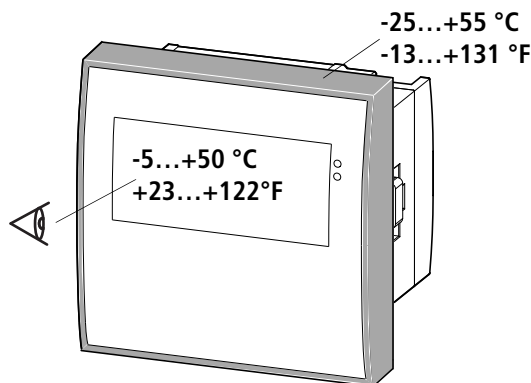
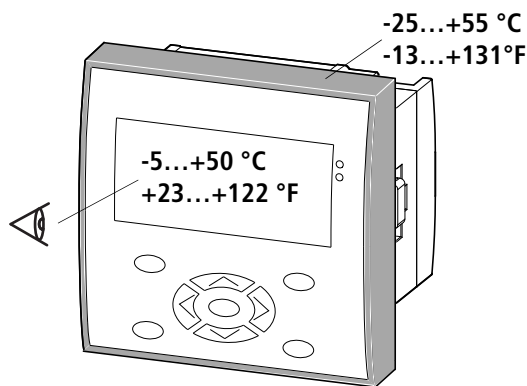
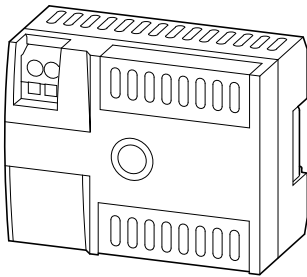

(en) **Electric current! Danger to life!**

Only skilled or instructed persons may carry out the following operations. The national regulations/specifications must be observed for the installation of the devices.



(de) **Lebensgefahr durch elektrischen Strom!**

Nur Elektrofachkräfte und elektrotechnisch unterwiesene Personen dürfen die im Folgenden beschriebenen Arbeiten ausführen. Die Stromversorgungsgeräte sind Einbaugeräte. Beachten Sie für die Installation der Geräte die länderspezifischen Vorschriften.



(fr) **Tension électrique dangereuse !**

Seules les personnes qualifiées et averties doivent exécuter les travaux ci-après. Les blocs d'alimentation sont des appareils faisant partie intégrante d'une installation. Veuillez respecter les normes de mise en œuvre spécifiques aux différents pays.



(es) **¡Corriente eléctrica! ¡Peligro de muerte!**

El trabajo a continuación descrito debe ser realizado por personas cualificadas y advertidas. Las fuentes de alimentación son aparatos de montaje. Para la instalación de los aparatos han de tenerse en cuenta las normativas/especificaciones a nivel local.



(it) **Tensione elettrica: Pericolo di morte!**

Solo persone abilitate e qualificate possono eseguire le operazioni di seguito riportate. Gli alimentatori sono unità per montaggio interno. Per l'installazione degli apparecchi è necessario rispettare le normative specifiche di ciascun paese.

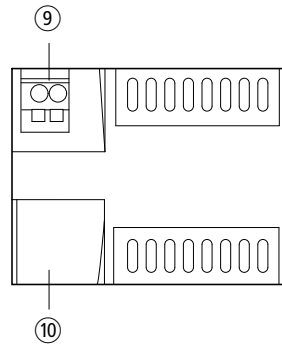
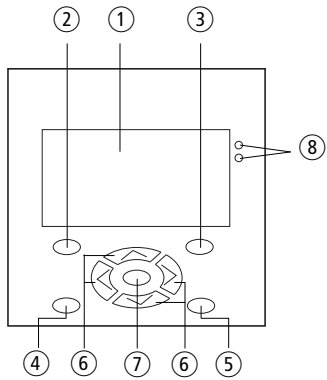

en

- ① LCD display
- ② DEL button
- ③ ALT button
- ④ ESC button
- ⑤ "Mode" button
- ⑥ Cursor buttons: right, left, up, down
- ⑦ OK button
- ⑧ optionally programmable LEDs
- ⑨ Voltage supply
- ⑩ Interface (with cover)
Terminal for connection cable

es

- ① Indicador LCD
- ② Tecla DEL
- ③ Tecla ALT
- ④ Tecla ESC
- ⑤ Tecla "Mode"
- ⑥ Teclas de cursor: derecha, izquierda, arriba, abajo
- ⑦ Tecla OK
- ⑧ LEDs de libre programación
- ⑨ Tensión de alimentación
- ⑩ Interface (con tapa)
Borne para cable de conexión al aparato

de

- ① LCD Anzeige
- ② DEL-Taste
- ③ ALT-Taste
- ④ ESC-Taste
- ⑤ Mode-Taste
- ⑥ Cursortasten: rechts, links, oben, unten
- ⑦ OK-Taste
- ⑧ frei programmierbare LED's
- ⑨ Spannungsversorgung
- ⑩ Schnittstelle (mit Abdeckung)
Klemme für Geräteanschlussleitung

it

- ① Visualizzatore LCD
- ② Tasto DEL
- ③ Tasto ALT
- ④ Tasto ESC
- ⑤ Tasto "Mode"
- ⑥ Tasti cursore, destra, sinistra, su, giù
- ⑦ Tasto OK
- ⑧ LED liberamente programmabili
- ⑨ Tensione di alimentazione
- ⑩ Interfaccia (con copertura)
Morsetto per cavo di collegamento

fr

- ① Afficheur à cristaux liquides
- ② Touche DEL
- ③ Touche ALT
- ④ Touche ESC
- ⑤ Touche « Mode »
- ⑥ Touches de direction : droite, gauche, haut, bas
- ⑦ Touche OK
- ⑧ DEL librement programmables
- ⑨ Alimentation
- ⑩ Interface (avec capot)
Borne pour câble de raccordement de l'appareil

Standard connection – Standardanschluss – Raccordement standard – Conexión estándar – Collegamento standard

Power supply – Spannungsversorgung – Tension d'alimentation – Tensión de alimentación – Tensione di alimentazione

MFD-CP4-CO

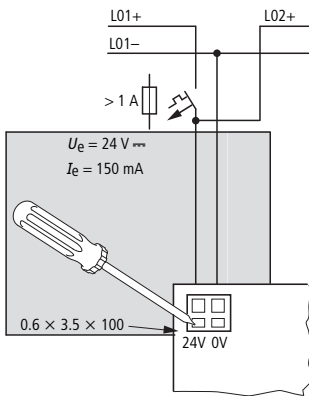

Temperature range – Temperaturbereich – Plage de température – Margen de temperatura – Campo temperatura:

-25...+55 °C (-13...+131 °F)

- (en) – LCD display legible in range 0 to 55 °C (32 °F to 131 °F)
– On no account allow condensation to form on the device!
- (de) – LCD-Anzeige im Bereich 0 bis 55 °C lesbar (32 °F bis 131 °F)
– Betauung des Gerätes unbedingt verhindern!
- (fr) – Afficheur à cristaux liquides lisible dans la plage 0 à 55 °C (32 °F à 131 °F)
– Eviter impérativement toute condensation sur l'appareil !
- (es) – El visualizador LCD es legible dentro de un margen entre 0 a 55 °C (32 °F a 131 °F)
– ¡Evitar que se produzca condensación en el aparato !
- (it) – Visualizzatore LCD leggibile ad una temperatura compresa tra 0 e 55 °C (da 32 °F a 131 °F)
– Impedire assolutamente la formazione di condensa sull'apparecchio!

- (en) **MFD-...-CP4-CO interface**
- (de) **Schnittstelle MFD-...-CP4-CO**
- (fr) **Interface MFD-...-CP4-CO**
- (es) **Interface MFD-...-CP4-CO**
- (it) **Interfaccia MFD-...-CP4-CO**

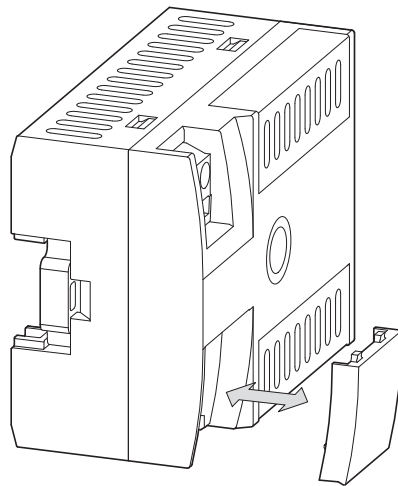

11/10 IL05013023Z

EC4P → MFD-CP4-CO

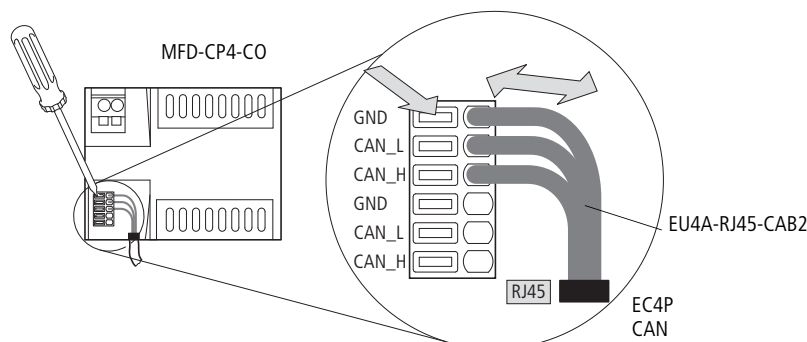
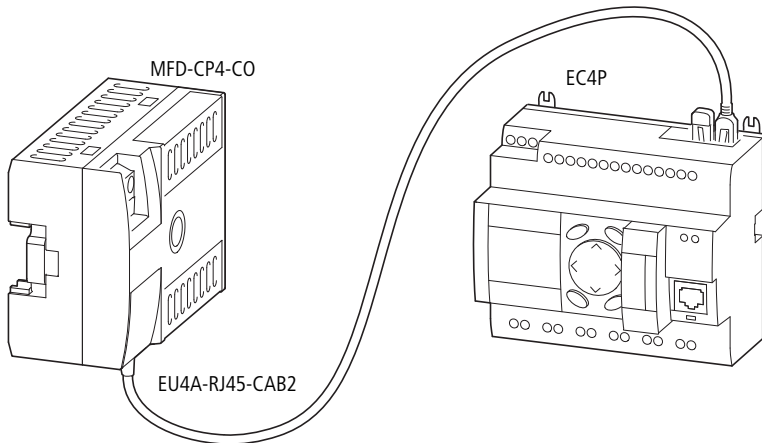

GND	red – rot – rouge – rojo – rosso
CAN_L	green – grün – vert – verde
CAN_H	black – schwarz – noir – negro – nero

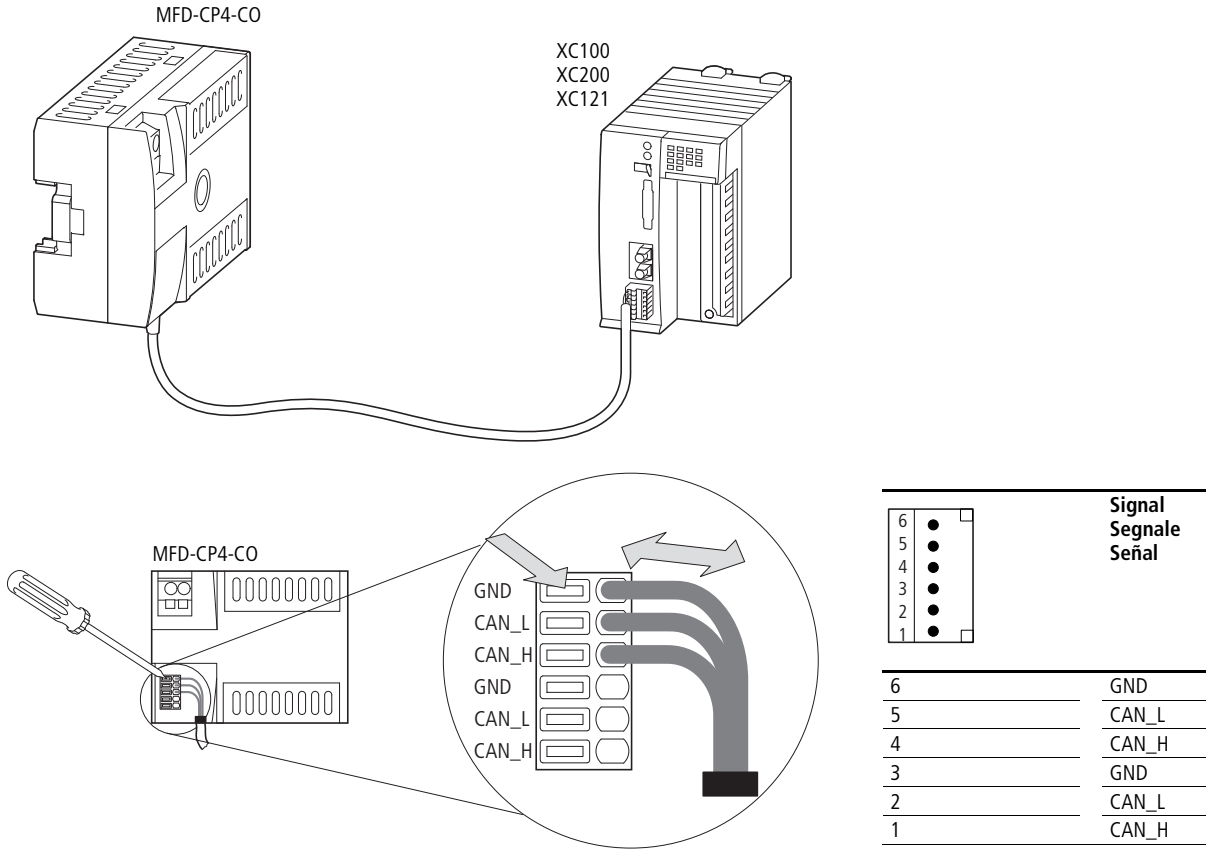

en Protective cover – de Schutzhaube – fr Capot – es Tapa protectora – it Calotta di protezione

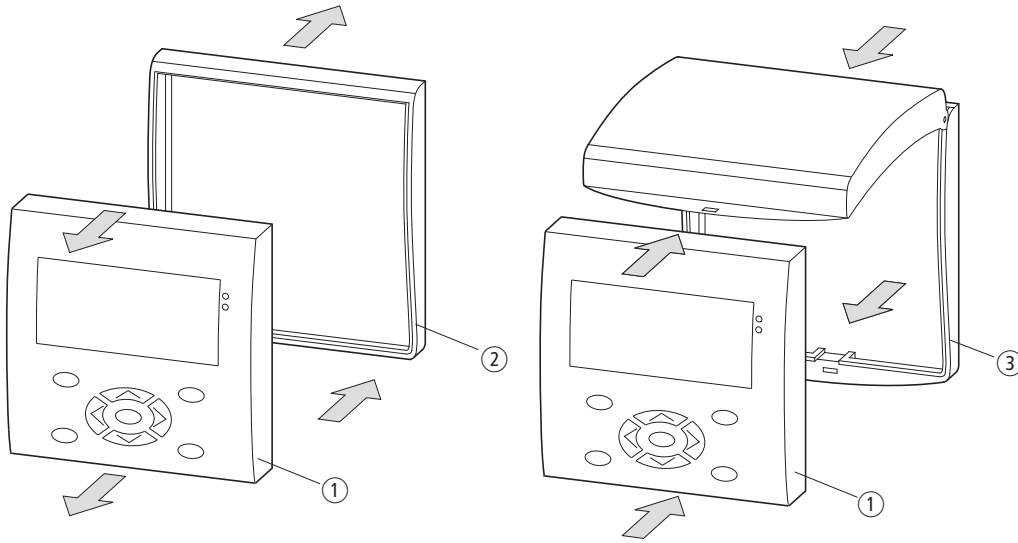

- ① MFD-80-(B)
- ② Titanate plate – Titan-Blende – Obturateur titane – Tapa de titanio – Piastra in titanio
- ③ MFD-XS-80

Position of the shroud – Lage der Haube – Position du capot – Posición de la caperuzza – Posizione della calotta

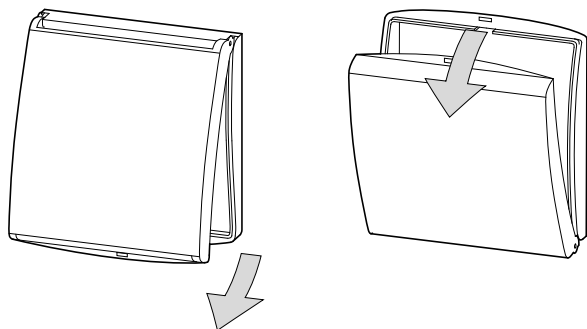

11/10 IL05013023Z

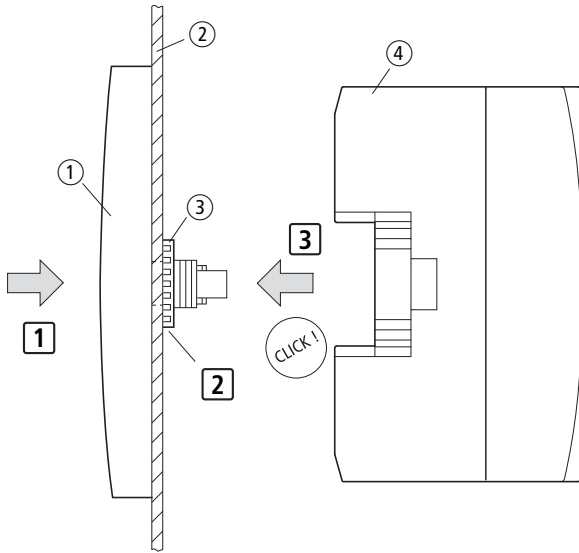

Warning! Risk of destruction !
Only permitted if the device is de-energized !

Warnung ! Zerstörungsgefahr!
Nur im spannungsfreien Zustand erlaubt!

Avertissement ! Risque de destruction !
Rischio di distruzione! Autorisé hors tension seulement !

¡Advertencia! ¡Peligro de destrucción!
¡Se permite sólo en estado libre de tensión!

Avvertimento! Rischio di distruzione!
Consentito solo in assenza di tensione!

2] M = 1.2 – 2 Nm
10.6 – 17.7 lb-in

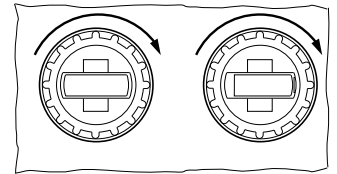

- en
- 1 MFD-80...
 - 2 Enclosure plate (CP4: 1 to 6 mm, 0.04 to 0.24")
 - 3 Fixing ring
 - 4 MFD-...-CP4-CO

- 1] Fitting MFD-80...
- 2] Fixing MFD-80...
- 3] Fitting MFD-...-CP4-CO

- es
- 1 MFD-80...
 - 2 Pared de caja (CP4: 1 a 6 mm, 0.04 a 0.24")
 - 3 Anillo de fijación
 - 4 MFD-...-CP4-CO

- 1] Enchufar MFD-80...
- 2] Fijar MFD-80...
- 3] Enchufar MFD-...-CP4-CO

- de
- 1 MFD-80...
 - 2 Gehäusewand (CP4: 1 bis 6 mm, 0.04 bis 0.24")
 - 3 Befestigungsring
 - 4 MFD-...-CP4-CO

- 1] MFD-80... stecken
- 2] MFD-80... befestigen
- 3] MFD-...-CP4-CO stecken

- it
- 1 MFD-80...
 - 2 Parete della custodia (CP4: 1 a 6 mm, 0.04 a 0.24")
 - 3 Anello di fissaggio
 - 4 MFD-...-CP4-CO

- 1] Inserire MFD-80...
- 2] Fissare MFD-80...
- 3] Inserire MFD-...-CP4-CO

- fr
- 1 MFD-80...
 - 2 Paroi du coffret (CP4 : 1 à 6 mm, 0.04 à 0.24")
 - 3 Colletette de fixation
 - 4 MFD-...-CP4-CO

- 1] Enficher MFD-80...
- 2] Fixation MFD-80...
- 3] Enficher MFD-...-CP4-CO

Remove card from MFD-80... – Baugruppe von MFD-80... entfernen – Retirer le module du MFD-80... – Rimuovere il modulo dall'MFD-80... – Quitar unidad de MFD-80...

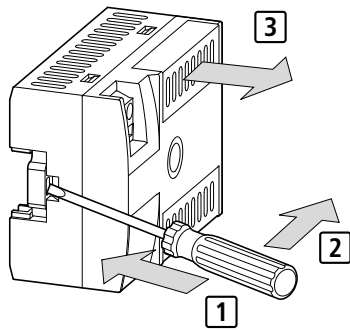

MFD-...-CP4...-CO

- 1 Put on screwdriver – Schraubendreher ansetzen – Engager un tournevis – Colocar el destornillador – Inserire il cacciavite
- 2 Actuate slide – Schieber betätigen – Actionner le coulisseau – Accionar la corredera – Attivare la saracinesca
- 3 Remove unit – Einheit abziehen – Retirer l'unité – Extraer la unidad – Estrarre l'unità



Warning! Risk of destruction !

Only permitted if the device is de-energized !

Warnung ! Zerstörungsgefahr!

Nur im spannungsfreien Zustand erlaubt!

Avertissement ! Risque de destruction !

Rischio di distruzione! Autorisé hors tension seulement !

¡Advertencia! ¡Peligro de destrucción!

¡Se permite sólo en estado libre de tensión!

Avvertimento! Rischio di distruzione!

Consentito solo in assenza di tensione!

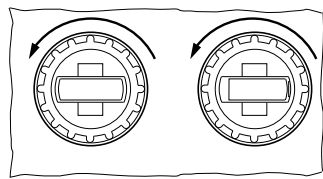

1

- en Loose and remove fixing rings.
- de Befestigungsringe lösen und entfernen.
- fr Desserrer et retirer collerettes de fixation.
- es Soltar y quitar anillos de fijación.
- it Allentare e rimuovere gli anelli di fissaggio.

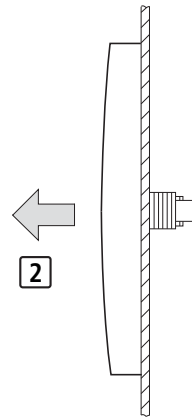

2

- en Remove MFD-80...
- de MFD-80... entfernen
- fr Retirer MFD-80...
- es Quitar MFD-80...
- it Rimuovere MFD-80...

en Mounting position – de Einbaulage – fr Position de montage – es Posición de montaje – it Posizione di montaggio

- en horizontal and vertical
- de waagrecht und senkrecht
- fr horizontale et verticale
- es horizontal y vertical
- it orizzontale e verticale

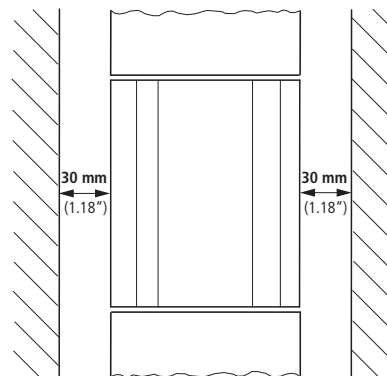
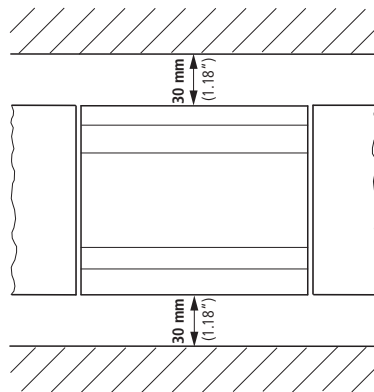

MFD-80...

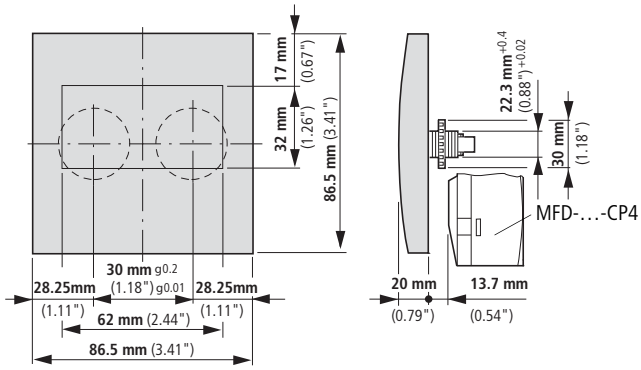

MFD-...-CP4-CO

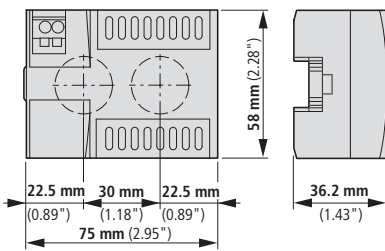

MFD-80... + MFD-...-CP4-CO

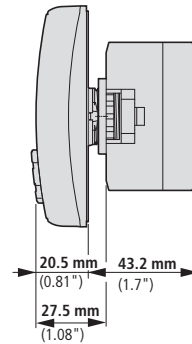

MFD-XS-80

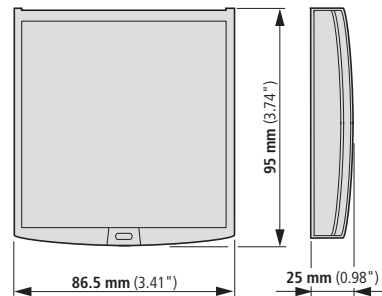

11/10 IL05013023Z

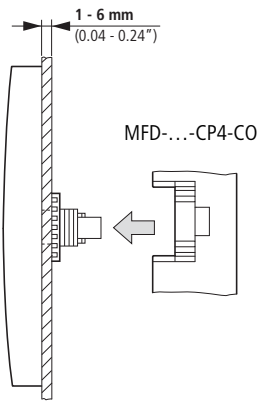

- (en) Template for holes, scale 1 : 1
(de) Bohrschablone M 1 : 1
(fr) Gabarit de perçage, échelle 1 : 1
(es) Plantilla para taladros, escala 1 : 1
(it) Dima di foratura, scala 1 : 1

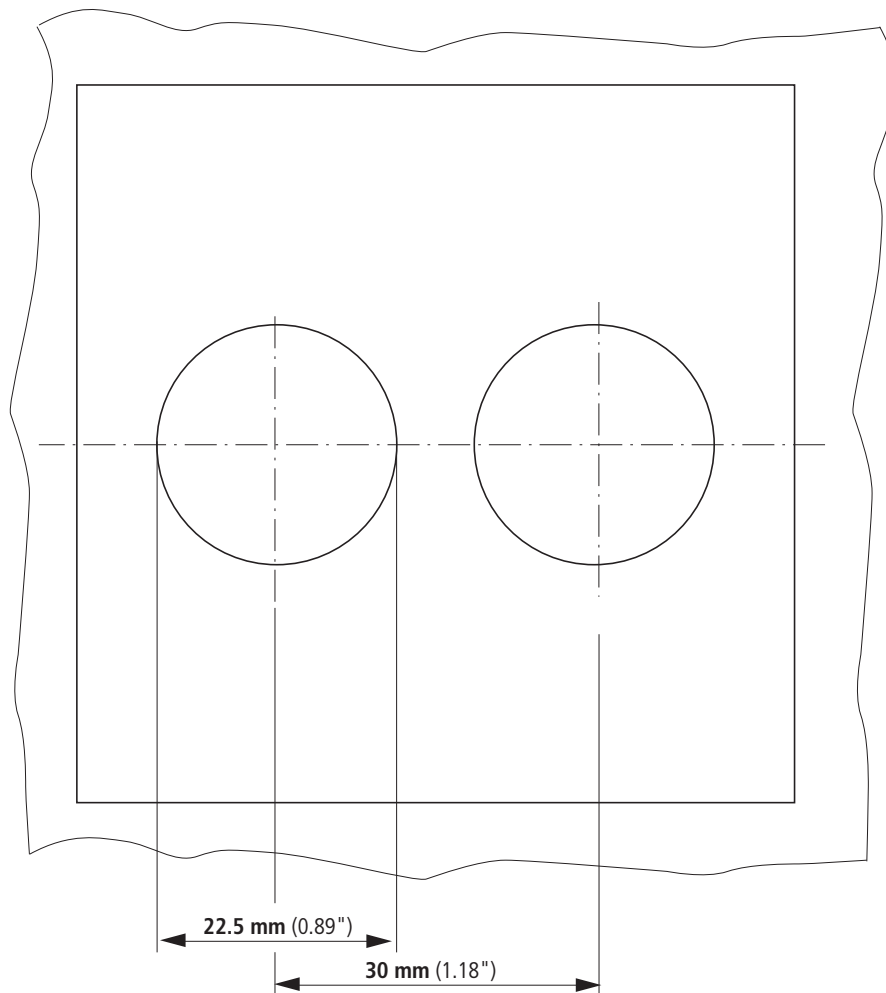

11/10 IL05013023Z

HAZARDOUS LOCATION – CSA (Canadian Standards Association) Certification

This equipment is suitable for use in CLASS I, DIVISION 2, GROUPS A, B, C AND D

WARNING: "EXPLOSION HAZARD – DO NOT DISCONNECT WHILE CIRCUIT IS LIVE UNLESS AREA IS KNOWN TO BE NON-HAZARDOUS"

EMPLACEMENTS DANGEREUX – Certification CSA (Canadian Standards Association)

Cet équipement est acceptable pour utilisation dans les EMBLEMES DANGEREUX DE CLASSE I, DIVISION 2, GROUPES A, B, C ET D

AVERTISSEMENT : « RISQUE D'EXPLOSION. NE PAS DÉBRANCHER TANT QUE LE CIRCUIT EST SOUS TENSION, A MOINS QU'IL NE S'AGISSE D'UN EMBLEMES NON DANGEREUX »