

Installation Instructions — iProx™ Inductive Proximity Sensor

CATALOG NUMBER KEY

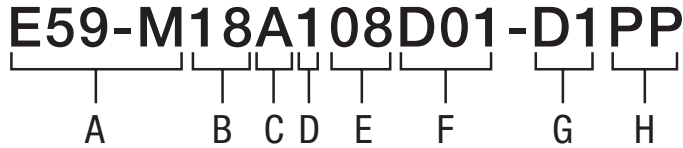

Key	Value	Description
A = Product Family	E59-M	iProx™ Family
B = Barrel Diameter	12	12-millimeter
	18	18-millimeter
	30	30-millimeter
C = Body and Cap	A	Stainless Steel, Shielded
	C	Stainless Steel, Unshielded
D = Indicator LED	1	Dual-Color, Green and Red
E = Maximum Range	Varies	Maximum Range in Millimeters
F = Connection	A01	3-Pin Micro AC Connector
	A01P	3-Pin Micro AC Pigtail
	A01PB	3-Pin Mini AC Pigtail
	C02	2-Meter Cable
	D01	4-Pin Micro DC Connector
	D01P	4-Pin Micro DC Pigtail
G = Output Voltage	A1	AC, N.O. by Default
	A2	AC, N.C. by Default
	D1	DC, Auto Sink or Source, N.O. by Default
	D2	DC, Auto Sink or Source, N.C. by Default
H = Optional Configurations	PP	Dual PNP Output
	NN	Dual NPN Output
	C	ChipMaster
	S1	SpeedSense 50 RPM
	S2	SpeedSense 100 RPM
	S4	SpeedSense 1,500 RPM

INTRODUCTION

The iProx is a field programmable inductive proximity sensor from Eaton featuring Cutler-Hammer's exclusive microprocessor-controlled SmartSense™ technology. This allows the iProx to perform unique sensing functions at extended ranges.

If required by your application, the sensing characteristics of the iProx can be modified by using a Microsoft Windows-based software application called ProxView (E59SW1) and a programming accessory (E59RP1 or E59TP1). In addition to adjusting sensing range and outputs, the software can be used to enable certain advanced sensing features disabled by default, such as band sensing, output delays and speed detection. For more detailed programming information, review the ProxView Software User Guide (P50228). This software can be freely downloaded from www.eatonelectrical.com/iprox.

Programming is not required. The iProx is shipped from the factory with default settings that are optimized for most applications.

Special versions of the iProx sensor, such as ChipMaster and SpeedSense, come pre-programmed from the factory to fulfill advanced application requirements without the need to program. These sensors can also be programmed using the ProxView software package.

Warning: The iProx sensor is a field programmable sensor with several configurable parameters. As such, do not use the iProx without testing the configuration prior to use. Failure to do so could result in an unsafe condition.

MOUNTING

The iProx is available in both shielded (embedded cap) and unshielded (exposed cap) versions. Mounting instructions for shielded and unshielded sensors are different.

Shielded sensors can be fully embedded or flush-mounted in surrounding metal.

Unshielded sensors typically require a metal-free zone surrounding the sensor cap. (See the figure below for dimensions.)

However, the Background Metal Rejection feature of the iProx allows even unshielded sensors to be mounted in a metal-rich environment. In most cases, enabling Background Metal Rejection will reduce the sensing range. Consult the ProxView Software User Guide (P50228) for more information.

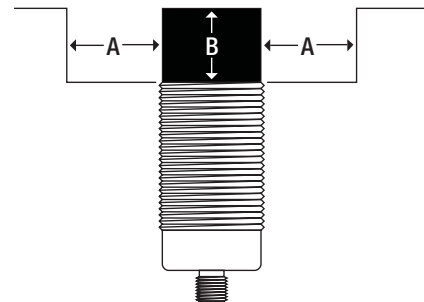

METAL-FREE ZONE DIMENSIONS

	A	B
Unshielded Sensor	1.5 x Sensing Range	Cap Height
Shielded Sensor	0	0



WARNING

IN ORDER TO AVOID ELECTRIC SHOCK OR OTHER POSSIBLE INJURY:

- DO NOT USE THIS FIELD PROGRAMMABLE PRODUCT WITHOUT TESTING THE SENSOR CONFIGURATION PRIOR TO USE. FAILURE TO DO SO COULD RESULT IN A HUMAN INJURY OR MAJOR EQUIPMENT DAMAGE. REFER TO THE PROXVIEW SOFTWARE USER GUIDE (P50228) FOR DETAILED PROGRAMMING INSTRUCTIONS.
- DO NOT USE THIS PRODUCT FOR HUMAN SAFETY APPLICATIONS. IT WAS NOT DESIGNED, TESTED OR RECOMMENDED FOR THIS USE.
- DO NOT USE THIS PRODUCT IN HAZARDOUS LOCATIONS (E.G. EXPLOSIVE ATMOSPHERES). IT WAS NOT DESIGNED, TESTED OR RECOMMENDED FOR THIS USE.
- ENSURE THE PRODUCT IS PROPERLY CONNECTED TO THE CORRECT POWER SUPPLY FOR THE APPLICATION. REFER TO THE SPECIFICATIONS AND WIRING DIAGRAMS IN THIS MANUAL.

SPECIFICATIONS

		2-Wire AC Sensors	3-Wire DC Sensors
Input Voltage		20-132 VAC	6-48 VDC
Load Current		5-500 mA, 5-250 mA > 50° C For all E59-M12... 5-300 mA, 200 mA > 50° C	< 500 mA @ 6-30 VDC < 300 mA @ 32-48 VDC
Voltage Drop		< 10 VAC	< 2.5 VDC
Burden Current		N/A	< 15 mA
Protection		Overcurrent ¹	Auto Reset
Switching Hysteresis		< 15% Rated Sensing Distance	
Repeat Accuracy		Shielded Models: < 1% Rated Sensing Distance Unshielded Models: < 3% Rated Sensing Distance	
Surge Capacity		3 A / 30 ms	
Temperature Range		-40° to +158° F (-40° to +70° C)	
Material of Construction		Housing: 303 Stainless Steel; End Bells: Polycarbonate; Face Caps: Ryton®; Cable: AWM Style 20387 (PVC)	
Vibration		10-55 Hz, 1 mm Amplitude, IEC 60068-2-6	
Shock		30 g, 11 ms, IEC 68-2-27	
Indicator LED		360° Viewable	
Enclosure Ratings		NEMA 4, 4X, 6, 6P, 12 and 13 (IP67) ²	
Response Time ³	Factory Default Mode	30 Hz (10 V/m)	Shielded (10 V/m) 12 mm: 580 Hz; 18 mm: 390 Hz; 30 mm: 240 Hz Unshielded (10 V/m) 12 mm: 300 Hz; 18 mm: 150 Hz; 30 mm: 90 Hz
	Side by Side Mode ⁴	30 Hz (10 V/m)	50 Hz (20 V/m)
	High Noise Immunity Mode	10 Hz (> 20 V/m)	10 Hz (> 20 V/m)

¹ Overcurrent protection for conductor size 20 AWG is 5 A; 22 AWG is 3 A; 24 AWG is 2 A.

² Our products conform to NEMA tests as indicated, however, some severe washdown applications can exceed these NEMA test specifications. For questions about a specific application, contact our Applications Department at (800) 426-9184.

³ The iProx sensor may be programmed to perform in "Side by Side" and high noise applications by using the ProxView Software (E59SW1) and a programming accessory (E59RP1 or E59TP1). For more information on these programming accessories, contact Eaton's Cutler-Hammer Sensor Applications Department at (800) 426-9184.

⁴ When mounting multiple iProx sensors in an area less than seven times its sensing range, it is recommended to set the noise immunity setting of the sensor to "Side by Side" mode. Refer to the ProxView Software User Guide (P50228) for details.

APPROXIMATE DIMENSIONS (IN/MM)

Cable Models

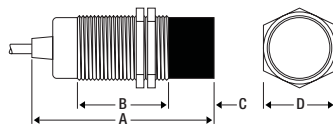

Size	Cap	A	B	C	D
12 mm	Shielded	2.86 (72.6)	1.98 (50.3)	0.02 (0.50)	0.67 (17)
	Unshielded	2.86 (72.6)	1.64 (41.6)	0.36 (9)	0.67 (17)
18 mm	Shielded	2.54 (64.5)	2.00 (50.9)	0.02 (0.50)	0.94 (24)
	Unshielded	2.54 (64.5)	1.47 (37.4)	0.55 (14)	0.94 (24)
30 mm	Shielded	2.74 (69.6)	2.13 (54.1)	0.03 (0.75)	1.41 (36)
	Unshielded	2.74 (69.6)	1.41 (35.8)	0.75 (19)	1.41 (36)

Micro Connector Models

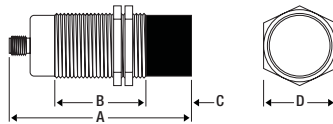

Size	Cap	A	B	C	D
12 mm	Shielded	3.05 (77.5)	1.98 (50.3)	0.02 (0.50)	0.67 (17)
	Unshielded	3.05 (77.5)	1.64 (41.6)	0.36 (9)	0.67 (17)
18 mm	Shielded	2.73 (69.3)	2.00 (50.9)	0.02 (0.50)	0.94 (24)
	Unshielded	2.73 (69.3)	1.47 (37.4)	0.55 (14)	0.94 (24)
30 mm	Shielded	2.92 (74.1)	2.13 (54.1)	0.03 (0.75)	1.41 (36)
	Unshielded	2.92 (74.1)	1.41 (35.8)	0.75 (19)	1.41 (36)

Note: Metal nuts are provided for equipment grounding means.

WIRING DIAGRAMS (NORMALLY OPEN AND NORMALLY CLOSED)

