

C441 Motor Insight™ Overload Relay (120V Control Powered) Product Installation Leaflet

⚠ DANGER

HAZARDOUS VOLTAGE CAN CAUSE ELECTRIC SHOCK AND BURNS. TO AVOID SHOCK HAZARD, DISCONNECT ALL POWER BEFORE ANY WORK IS PERFORMED ON THIS DEVICE. FAILURE TO DO SO WILL RESULT IN PERSONAL INJURY, DEATH OR SUBSTANTIAL PROPERTY DAMAGE

⚠ DANGER

UNE TENSION ÉLECTRIQUE DANGEREUSE PEUT CAUSER DES CHOCS ÉLECTRIQUES ET DES BRÛLURES. POUR ÉVITER DES CHOCS ÉLECTRIQUES, DÉBRANCHER L'ALIMENTATION AVANT D'Y EFFECTUER DU TRAVAIL. L'INOBSERVATION DE CES INSTRUCTIONS ENTRAÎNERA DES BLESSURES CORPORELLES GRAVES, LA MORT OU DES DÉGÂTS MATÉRIELS SUBSTANTIELS.

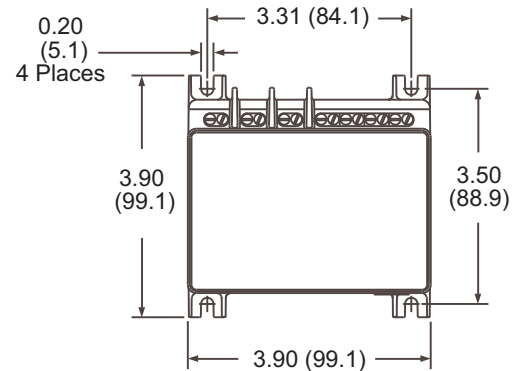

Figure 1. Mount with 10-32 Hardware Torque to 25 in-lb.

Voltage Ratings

Motor Insight overload relay is powered by 120V control power between X1 - X2. This voltage range for the various models is given in the following table.

Table 1. Voltage Range

Nominal Rating	Catalog Number	Input Voltage Range
3- PHASE MOTOR INPUT 200 - 600 V	C4410109NOUI C4410590NOUI	200 – 600 Vac; (50/60 Hz) +10% - 15%
CONTROL POWER INPUT 110 - 120V	C4410109NOUI C4410590NOUI	110 - 120 Vac; (50/60 Hz) +10% - 15%

Wiring

Pass motor leads through Motor Insight overload relay CT pass through. If multiple passes of the motor leads are required, make sure that the current flow is from top to bottom through Motor Insight overload relay. If external CTs are used, pass the 5 amp secondary of the external CTs through Motor Insight overload relay internal CTs. See **Table 3** for wrap and CT multiplier.

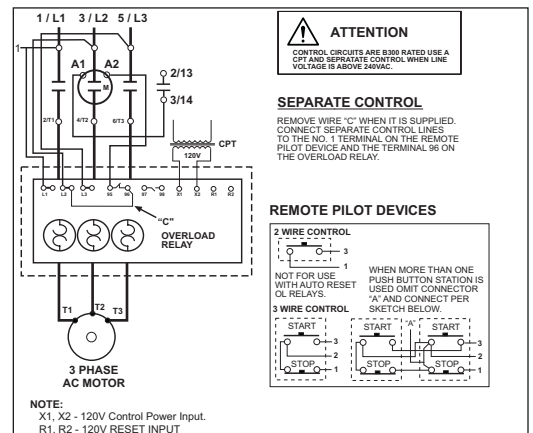

Figure 2. Typical Starter Application Sample Wiring Diagram

Motor Insight overload relay is factory set for manual reset operation. See **Table 5** for automatic reset operation.

⚠ WARNING AVERTISSEMENT

AUTOMATIC RESET IS NOT INTENDED FOR TWO-WIRE CONTROL DEVICES.

CE DISPOSITIF DE REENCLenchement AUTOMATIQUE NE CONVIENT PAS AUX COMMANDES À DEUX CONDUCTEURS.



Powering Business Worldwide

Terminal Connections

Motor Insight overload relay provides the following terminal connections. NC 95/96 contact is open when the device is unenergized.

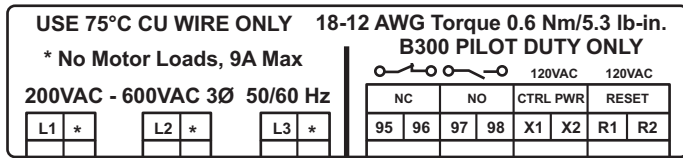

Figure 3. Terminal Connection Diagram

Table 2. Terminal Connection Specifications

Name	Designation	Input	Description
Line Voltage	L1, L2, L3	Line Voltage	Three-phase line voltage input - L1, L2, L3 connections must correspond to the respective CT1, CT2, CT3 current leads. - Inputs must have short circuit protection - Terminal provided for wiring control power transformer (9A maximum capacity).
Fault Relay	95/96	UL@ 508 B300	- 95/96 Contact opens when the unit is faulted or unpowered.
Programmable Auxiliary Relay*	97/98	UL@ 508 B300	- 97/98 Contact closes when the unit is faulted or unpowered.
Control Power	X1 X2	UL 508 B300	110-120V control power input +10% / -15%
Reset Input	R1 R2	120 Vac +10%/-15%	Fault Reset Input.

* See section 6.7 of Users Manual MN04209001E for instructions to configure the programmable auxiliary relay, which changes the behavior of the relay from the default and allows for greater flexibility and alarming.

CAUTION!

THE OPENING OF BRANCH-CIRCUIT PROTECTIVE DEVICE MAY BE AN INDICATION THAT A FAULT HAS BEEN INTERRUPTED. TO REDUCE THE RISK OF FIRE OR ELECTRIC SHOCK, CURRENT-CARRYING PARTS AND OTHER COMPONENTS OF THE CONTROLLER SHOULD BE EXAMINED AND REPLACED IF DAMAGED. IF BURNOUT OF THE ELEMENT OF AN OVERLOAD RELAY OCCURS, THE COMPLETE OVERLOAD RELAY SHOULD BE REPLACED.

ATTENTION

LE DÉCLENCHEMENT DU DISPOSITIF DE PROTECTION DES DÉRIVATIONS PEUT SIGNIFIER QU'UN COURANT DE DÉFAUT A ÉTÉ INTERROMPU. POUR RÉDUIRE LE RISQUE D'INCENDIE OU DE CHOC ÉLECTRIQUE, LES PIÈCES PORTEUSES DE COURANT ET LES AUTRES COMPOSANTS DE LA COMMANDE DOIVENT ÊTRE VÉRIFIÉS ET REMPLACÉS S'ILS SONT ENDOMMAGÉS. SI L'ÉLÉMENT PORTEUR DE COURANT DU RELAIS DE SURCHARGE GRILLE, LE RELAIS DE SURCHARGE ENTIER DOIT ÊTRE REMPLACÉ.

Initial Configuration

On initial power-up, Motor Insight overload relay displays a "rOF" message. This indicates that the fault relay is OFF. Configure the device for the application prior to resetting the device.

To turn the fault relay OFF, press the Trip button.

Programming Set Points

Motor Insight overload relay is easy to configure. Viewing and editing protection set points can be performed in the Protection and Operation Mode. The following steps outline the procedure for modifying any of the set points.

Step 1: Press Mode button until Protection or Operation Mode Led is lit.



Step 2: Press Up or Down button until the desired O/P LED is lit. Display shows the current parameter value.



Step 3: Press the Edit/Save button. The display now shows the parameter value but is now flashing.



Step 4: Use the Up/Down button to adjust the parameter to the desired value.



Step 5: Press the Edit/Save button. The Display now shows the new parameter value that has been saved by the device.



Configuring the Thermal Overload Protection Feature

Motor Insight overload relay features electronic motor overload protection. This feature protects the motor and power wiring against overheating caused by excessive current for extended periods of time.

The trip current is programmed by entering the motor full load amperes (FLA) using the Motor FLA parameter. The trip class (5 to 30) is set using the Trip Class parameter.

The FLA range of the overload relay can be modified with the use of multiple turns through the CTs or with the use of external CTs. Use the following tables to appropriately configure the device for the application. If the application requires the FLA range to be extended, program the CT multiplier first.

Table 3A. FLA Range

Current Range	Catalog Number	Motor FLA	Number of Conductors Through CT	CT Multiplier
A (1 – 9 Amps)	C4410109NOUI	1 – 5	2	2
		2 – 9	1	1
		60 – 135	1	150 - (150:5)
		120 – 270	1	300 - (300:5)
		240 – 540	1	600 - (600:5)
B (5 – 90 Amps)	C4410590NOUI	5 – 22.5	4	4
		6.67 – 30	3	3
		10 – 45	2	2
		20 – 90	1	1

Important Note: After an overload trip, Motor Insight relay cannot be reset until the thermal model decays to a thermal capacity that is thermally safe for a motor restart. Cycling the power does not reset the thermal model.

Table 3B. Service Factor FLA Setting

Service Factor	Motor FLA Setting
>1.15	Enter the motor nameplate FLA
=1.10	Enter the FLA as (1.1 * nameplate FLA/1.15)

Protection Set Point Summary Table

Table 4 Protection Menu Set Points

Type	Trip Threshold	Trip Delay ¹	Default(s)	Notes
Jam	50 – 400% of FLA	1 – 20 Seconds	400% 2 Seconds	This protection is disabled by default.
Current Unbalance	1 – 30%	1 – 20 Seconds	15% 10 Seconds	
Ground Fault	0.3 – 2.0 Amps (A) 3.0 – 20 Amps (B)	1 – 60 Seconds	1 Amp (A) 10 Amps (B) 2 Seconds	See user manual for ranges when CT Multiplier is not set to 1.
Phase Reversal	0 = Don't Care 1 = ACB 2 = ABC	2 Seconds (not adjustable)	1 = ACB	By default, the Phase Reversal fault is in alarm-no-trip mode. The MI fault relay will not close in a phase reversal condition.
Under Current	10 – 90% of FLA	1 – 60 Seconds	50% 5 Seconds	This protection is disabled by default.
Low Power (kW)	See User Manual For Ranges	1 – 60 Seconds	5 Seconds	This protection is disabled by default.
High Power (kW)	See User Manual For Ranges	1 – 60 Seconds	5 Seconds	This protection is disabled by default.
Overvoltage	170 – 660	1 – 20 Seconds	632 Volts 10 Seconds	By default, the overvoltage fault is in alarm-no-trip mode. The MI fault relay will not close in an overvoltage condition.
Undervoltage	170 – 660	1 – 20 Seconds	216 Volts 10 Seconds	By default, the undervoltage fault is in alarm-no-trip mode. The MI fault relay will not close in an undervoltage condition.
Voltage Unbalance	1 – 20%	1 – 20 Seconds	6% 10 Seconds	By default, the Voltage Imbalance fault is in alarm-no-trip mode. The MI fault relay will not close in a voltage unbalance condition.

¹ Trip delay settings can be adjusted using the Advanced Configuration Parameter.

Operation Set Point Summary

WARNING

THE MOTOR INSIGHT OVERLOAD RELAY MAY RESET AT ANY TIME ENABLING A MOTOR START. WHEN FAULTED (FAULT LED IS ON), THE READY LED WILL FLASH WHEN AN AUTO RESET IS PENDING.

AVERTISSEMENT

LE RELAIS DE SURCHARGE MOTOR INSIGHT PEUT SE RÉINITIALISER À TOUT MOMENT PERMETTANT UN DÉMARRAGE DU MOTEUR. LORSQUE SE PRODUIT UNE DÉFAILLANCE (LE VOYANT DE DÉFAILLANCE DEL EST ACTIVÉ), LE VOYANT DEL « READY » CLIGNOTE LORSQU'UNE RÉINITIALISATION AUTOMATIQUE EST EN COURS.

Table 5 Operational Menu Set Points

Type	Range	Default(s)	Notes
Motor FLA	See Table 3	2 Amps (A) 20 Amps (B)	
Trip Class	5 – 30	20	
Fault Reset Dly (m)	2 – 500 Minutes	8 Minutes	This is the delay after a motor fault (Thermal Overload, Jam, Current Unbalance). This timer inhibits a reset so that the motor can cool down.
Fault Reset (#)	0 – 4, A OL.1-OL.4, OL.A	1	Number of auto-reset attempts after a motor fault. 0 = manual, A = auto, 1 – 4 = semi-auto. The Fault Reset (#) will be restored after the motor has been running for 15 minutes. The OL. prefix indicates that the setting applies to Overload trips, only.
Low kW Trip Dly (s)	1 – 60 Seconds	5 Seconds	
Load Reset Dly (s)	2 – 500 Minutes or Automatic	20 Minutes	This is the delay after an undercurrent, low power, or high power trip. A = automatic – Load reset delays are computed based on previous motor run times.
Load Resets (#)	0 – 4, A	1	Number of auto-reset attempts after a load fault. 0 = manual, 1 – 4 = semi-auto, A = automatic. The Load Reset (#) will be restored after the motor has been running for 70 seconds.
Restart Delay Time	0 – 500 Seconds	10 Seconds	Inhibits a start after power-up. Useful when multiple motors are brought on-line at the same time.
CT Multiplier	1, 2, 150, 300, 600 (A) 1, 2, 3, 4 (B)	1	If using multiple turns or external CTs, this parameter must be configured appropriately.
Device Address	1 – 247	1	
Advanced Config			See User Manual MN04209001E.

Fault Codes

After a trip, Motor Insight overload relay will indicate the Trip reason with a Fault Code on the display and by illuminating the appropriate Protection/Operation (P/O) LEDs.

Table 6. Fault Codes

Fault	Code	User Interface			Notes
		Mode LED	P/O LED	Display	
Number of Restarts Exceeded	1	Operation	Fault Reset Tries & Load Reset Tries	rEt	Could result from excessive motor or load faults.
Remote Off	2	None	None	rOF	Relay turned off (network or UI).
Contactors Failure	3	Protection	Current Unbalance %	F.03	Voltage and current phase loss.
Low Power (kW)	15	Protection	Low Power (kW)	F.04	
Motor Overload	5	Operation	Trip Class	F.05	
Ground Fault	6	Protection	Ground Fault (A)	F.06	
Current Unbalance	7	Protection	Current Unbalance %	F.07	
Current Phase Loss	8	Protection	Current Unbalance %	F.08	Current phase loss without voltage phase loss.
Reserved	9				
High Power (kW)	10	Protection	High Power (kW)	F.10	
Overvoltage	11	Protection	Overvoltage (V)	F.11	
Undervoltage	12	Protection	Undervoltage (V)	F.12	
Voltage Unbalance	13	Protection	Voltage Unbalance %	F.13	
Jam	14	Protection	Jam Trip %	F.14	
Under Current	4	Protection	Under Current %	F.15	
Phase Rotation	16	Protection	Phase Rotation	F.16	
Other					Consult User Manual.

Display Messages

The following display messages may appear on Motor Insight overload relay user interface to indicate status.

Table 7. Display Messages

Message	Description
rOF	The relay has been turned off.
rSt	The Restart Delay is timing down. Caution — an auto-reset attempt is pending.
rEt	The number of auto-resets attempts has been exceeded. A manual reset is required.
ub	A voltage imbalance has been detected. This message will flash with the displayed parameter in the alarm-no-trip mode.
HI	A high voltage condition has been detected. This message will flash with the displayed parameter in the alarm-no-trip mode.
LO	A low voltage condition has been detected. This message will flash with the displayed parameter in the alarm-no-trip mode.
1PH	A voltage phase loss condition has been detected. This message will flash with the displayed parameter in the alarm-no-trip mode.
gnd	A ground fault condition has been detected. This message will flash with the displayed parameter in the alarm-no-trip mode.
OFF	The protection parameter is disabled.
999	The display parameter exceeds the display range.

Eaton Corporation
 Electrical Sector
 1000 Cherrington Parkway
 Moon Township, PA 15108
 United States
 877-ETN-CARE (877-386-2273)
 Eaton.com

© 2009 Eaton Corporation
 All Rights Reserved
 Printed in USA
 Publication No. IL04209007E Rev005
 May 2011



PowerChain Management is a registered trademark of Eaton Corporation.

All other trademarks are property of their respective owners.