

# C441 PROFIBUS Module (C441Q, C441S, C441QS, C441SS)

## User Manual

Effective July 2015  
New Information



C441Q & C441S



C441QS & C441SS



*Powering Business Worldwide*

## **Disclaimer of Warranties and Limitation of Liability**

The information, recommendations, descriptions and safety notations in this document are based on Eaton Corporation's ("Eaton") experience and judgment and may not cover all contingencies. If further information is required, an Eaton sales office should be consulted. Sale of the product shown in this literature is subject to the terms and conditions outlined in appropriate Eaton selling policies or other contractual agreement between Eaton and the purchaser.

THERE ARE NO UNDERSTANDINGS, AGREEMENTS, WARRANTIES, EXPRESSED OR IMPLIED, INCLUDING WARRANTIES OF FITNESS FOR A PARTICULAR PURPOSE OR MERCHANTABILITY, OTHER THAN THOSE SPECIFICALLY SET OUT IN ANY EXISTING CONTRACT BETWEEN THE PARTIES. ANY SUCH CONTRACT STATES THE ENTIRE OBLIGATION OF EATON. THE CONTENTS OF THIS DOCUMENT SHALL NOT BECOME PART OF OR MODIFY ANY CONTRACT BETWEEN THE PARTIES.

In no event will Eaton be responsible to the purchaser or user in contract, in tort (including negligence), strict liability or otherwise for any special, indirect, incidental or consequential damage or loss whatsoever, including but not limited to damage or loss of use of equipment, plant or power system, cost of capital, loss of power, additional expenses in the use of existing power facilities, or claims against the purchaser or user by its customers resulting from the use of the information, recommendations and descriptions contained herein. The information contained in this manual is subject to change without notice.

Cover Photo: C441 PROFIBUS Module.

## Support Services

The goal of Eaton is to ensure your greatest possible satisfaction with the operation of our products. We are dedicated to providing fast, friendly, and accurate assistance. That is why we offer you so many ways to get the support you need. Whether it's by phone, fax, or email, you can access Eaton's support information 24 hours a day, seven days a week. Our wide range of services is listed below.

You should contact your local distributor for product pricing, availability, ordering, expediting, and repairs.

### Website

Use the Eaton website to find product information. You can also find information on local distributors or Eaton's sales offices.

### Website Address

[www.eaton.com/electrical](http://www.eaton.com/electrical)

### EatonCare Customer Support Center

Call the EatonCare Support Center if you need assistance with placing an order, stock availability or proof of shipment, expediting an existing order, emergency shipments, product price information, returns other than warranty returns, and information on local distributors or sales offices.

Voice: 877-ETN-CARE (386-2273) (8:00 am–6:00 pm EST)  
FAX: 800-752-8602

After-Hours Emergency: 800-543-7038  
(6:00 pm–8:00 am EST)

### Technical Resource Center

Voice:  
877-ETN-CARE (386-2273) (8:00 am–5:00 pm EST)  
FAX: 828-651-0549  
e-mail: [TRC@Eaton.com](mailto:TRC@Eaton.com)

## Table of Contents

### SAFETY

Definitions and Symbols .....	vi
Hazardous High Voltage .....	vi
Warnings and Cautions .....	vi

### OVERVIEW

PROFIBUS Specifications .....	1
-------------------------------	---

### INTRODUCTION

### RATINGS

### MOUNTING AND DIMENSIONS

C441Q and C441S .....	5
-----------------------	---

### CONNECTIONS AND SWITCH SETTINGS

Connecting the C441, C440, S611 and S811+ to a PROFIBUS Network .....	9
Setting the PROFIBUS Address .....	10
Power and I/O Wiring Diagrams for the C441Q and C441S Modules .....	11
Power and I/O Wiring Diagrams for the C441QS and C441SS Modules .....	13
PROFIBUS Status Indicators .....	14
Connecting and Disconnecting a C441 PROFIBUS Module from the C440, C441, S611, S811+ or as a Stand-Alone I/O Module .....	14

### CONFIGURATION USING THE PROFIBUS CONFIGURATION FILE

C441 Motor Insight Overload Protection Relay .....	16
C440 Overload Protection Relay .....	18
S611 Soft Starter .....	19
S811+ Soft Starter .....	21

### PROFIBUS I/O PARAMETERS

Cyclic IO Data for C441, C440, S611, S811+ and Stand-Alone I/O .....	25
C441 Motor Insight Overload Protection Relay .....	26
C440 Overload Protection Relay .....	28
S611 Soft Starter .....	30
S811+ Soft Starter .....	32

### PROFIBUS DIAGNOSTIC TELEGRAMS

C441 Motor Insight Overload Protection Relay .....	36
C440 Overload Protection Relay .....	38
S611 Soft Starter .....	40
S811+ Soft Starter .....	42

### APPLICATION EXAMPLE: OPERATING A C441 MOTOR INSIGHT WITH A SIEMENS PLC ON PROFIBUS-DP

Introduction .....	45
System Overview .....	45
Creating a Project in Siemens Simatic Software .....	45
Setting up the Configuration File in the Simatic Software .....	55
Assigning Tag Names to C441 Motor Insight I/O Addresses .....	56
Downloading the Program to the Siemens S7 PLC .....	60
References .....	66
Additional Help .....	66

**List of Figures**

Figure 1. Installation Diagram . . . . . **5**  
Figure 2. C441Q and C441S Product Dimensions (Attached to C441 Base Unit) . . . . . **6**  
Figure 3. Mounting of Stand-Alone Model . . . . . **7**  
Figure 4. Stand-Alone Dimensions . . . . . **8**  
Figure 5. C440 to a C441QS/SS . . . . . **9**  
Figure 6. S611 to a C441QS/SS . . . . . **9**  
Figure 7. Pin Out for PROFIBUS DB9 . . . . . **9**  
Figure 8. Power and Modbus RS-485 Connections . . . . . **10**  
Figure 9. C441Q: 24 Vdc Wiring Diagram . . . . . **11**  
Figure 10. C441S: 120 Vac Wiring Diagram . . . . . **12**  
Figure 11. C441QS—24 Vdc Input Specification . . . . . **13**  
Figure 12. C441SS—120 Vac Input Specification . . . . . **13**  
Figure 13. DIP Switch Service 3 Example. . . . . **14**

## List of Tables

Table 1. PROFIBUS Specifications . . . . .	<b>1</b>
Table 2. Product Selection . . . . .	<b>2</b>
Table 3. Environmental Ratings of the Module . . . . .	<b>3</b>
Table 4. Approvals and Certifications . . . . .	<b>3</b>
Table 5. Input Power Supply Requirements . . . . .	<b>3</b>
Table 6. Environmental Ratings of the Module . . . . .	<b>3</b>
Table 7. EMC Requirement . . . . .	<b>3</b>
Table 8. Input Power Supply Requirements . . . . .	<b>3</b>
Table 9. Material Requirement . . . . .	<b>4</b>
Table 10. 120 Vac Input Specification . . . . .	<b>4</b>
Table 11. 24 Vdc Input Specification . . . . .	<b>4</b>
Table 12. Relay Specification . . . . .	<b>4</b>
Table 13. Pilot Duty Relay Requirements . . . . .	<b>4</b>
Table 14. 24 Vdc Supply Connection . . . . .	<b>9</b>
Table 15. PROFIBUS DIP Switch Settings . . . . .	<b>10</b>
Table 16. PROFIBUS Status LEDs . . . . .	<b>14</b>
Table 17. C441 Motor Insight Configuration File . . . . .	<b>16</b>
Table 18. C440 Overload Supported Configuration File . . . . .	<b>18</b>
Table 19. S611 Soft Starter Configuration File . . . . .	<b>19</b>
Table 20. S811+ Soft Starter Configuration File . . . . .	<b>21</b>
Table 21. C441 Motor Insight Available IO Data for Cyclic Polling . . . . .	<b>26</b>
Table 22. C441 Motor Insight Available IO Data for Cyclic Polling (PROFIBUS) . . . . .	<b>26</b>
Table 23. C440 Available IO Data for Cyclic Polling . . . . .	<b>28</b>
Table 24. S611 Available IO Data for Cyclic Polling . . . . .	<b>30</b>
Table 25. S811+ Available IO Data for Cyclic Polling . . . . .	<b>32</b>
Table 26. C441 Diagnostic Telegram . . . . .	<b>36</b>
Table 27. C440 Diagnostic Telegram . . . . .	<b>38</b>
Table 28. Ext Diag Bit Key . . . . .	<b>39</b>
Table 29. S611 Diagnostic Telegram . . . . .	<b>40</b>
Table 30. S811+ Soft Starter Diagnostic Telegram . . . . .	<b>42</b>
Table 31. Ext Diag Bit Key . . . . .	<b>44</b>

## Safety

### Definitions and Symbols

---

 **WARNING**

---

**This symbol indicates high voltage. It calls your attention to items or operations that could be dangerous to you and other persons operating this equipment. Read the message and follow the instructions carefully.**



This symbol is the "Safety Alert Symbol." It occurs with either of two signal words: CAUTION or WARNING, as described below.

---

 **WARNING**

---

**Indicates a potentially hazardous situation which, if not avoided, can result in serious injury or death.**

---

 **CAUTION**

---

Indicates a potentially hazardous situation which, if not avoided, can result in minor to moderate injury, or serious damage to the product. The situation described in the CAUTION may, if not avoided, lead to serious results. Important safety measures are described in CAUTION (as well as WARNING).

### Hazardous High Voltage

---

 **WARNING**

---

**Motor control equipment and electronic controllers are connected to hazardous line voltages. When servicing drives and electronic controllers, there may be exposed components with housings or protrusions at or above line potential. Extreme care should be taken to protect against shock.**

Stand on an insulating pad and make it a habit to use only one hand when checking components. Always work with another person in case an emergency occurs. Disconnect power before checking controllers or performing maintenance. Be sure equipment is properly grounded. Wear safety glasses whenever working on electronic controllers or rotating machinery.

### Warnings and Cautions

This manual contains clearly marked cautions and warnings which are intended for your personal safety and to avoid any unintentional damage to the product or connected appliances.

**Please read the information included in cautions and warnings carefully.**

## Overview

The C441 PROFIBUS communication adapter is a DPV0 slave device used to connect the C441 Motor Insight® and C440 protective relay and S611 and S811+ soft starters to a PROFIBUS network. The C441Q/S PROFIBUS adapter connects to the side of the Motor Insight and the S611 soft starter, and allows the user to access setup parameters and IO data of the Motor Insight and the S611 over a PROFIBUS network.

The C441QS/SS is a stand-alone PROFIBUS adapter that connects to the C440, S611 and S811+ via hardwired connections (DO/DI) and allows the user to access setup parameters and IO data of the C440, S611 and S811+ over a PROFIBUS network.

The C441QS/SS can also be used as a 4 digital input, 2 relay output stand-alone IO module on a PROFIBUS network.

The C441 PROFIBUS communication adapters provide the user with the ability to:

- Configure C441 Motor Insight, C440 OL relay, S611 and S811+ soft starter and stand-alone IO setup parameters over a PROFIBUS network
- Create custom IO assemblies based upon their applications needs
- Exchange IO between a master and slave over a PROFIBUS network
- Read out diagnostic information concerning the health of the devices connected to the C441 PROFIBUS interface modules

## PROFIBUS Specifications

**Table 1. PROFIBUS Specifications**

Item	Specification
PROFIBUS Communications	DPV0
Vendor Identification Number	0x019D
PNO Identification Number	0x0C98
Maximum IO Modules	28
Maximum Input Data	100 bytes
Maximum Output Data	20 bytes
Max Diagnostic Message length	21 bytes
Supported PROFIBUS Data rates	9.6 k, 19.2 k, 45.5 k, 93.75 k, 187.5 k, 500 k, 1.5 M, 3 M, 6 M, 12 M
Optional Features	Freeze; Sync; and Fail-safe supported
GSD File	019D0C98.gsd @ <a href="http://www.eaton.com">www.eaton.com</a>



## Introduction

The C441 PROFIBUS modules enable PROFIBUS communications for the following Eaton devices.

- C441 Motor Insight overload and monitoring relay
- C440 Overload and monitoring relay
- S611 Soft Starter
- S811+ Soft Starter

The device can also be used stand-alone as a PROFIBUS I/O block.

The table below describes the products covered in this manual and their primary usage.

**Table 2. Product Selection**

<b>Catalog Number</b>	<b>Description</b>	<b>Use With</b>
C441Q	Plug-In PROFIBUS Module with 120 Vac Inputs and Relay Outputs	C441 Motor Insight, S611 Soft Starter
C441S	Plug-In PROFIBUS Module with 24 Vdc Inputs and Relay Outputs	C441 Motor Insight, S611 Soft Starter
C441QS	Stand-alone PROFIBUS Module with 120 Vac Inputs and Relay Outputs	C440 Overload, S611 Soft Starter, I/O Block, S811+ Soft Starter
C441SS	Stand-alone PROFIBUS Module with 24 Vdc Inputs and Relay Outputs	C440 Overload, S611 Soft Starter, I/O Block, S811+ Soft Starter

The PROFIBUS module provides the following key features.

- Supports PROFIBUS protocol
- 4 Discrete Input Points and 2 Output relays

## Ratings

The following ratings apply to the C441Q and C441S.

**Table 3. Environmental Ratings of the Module**

Description	Rating	
Transportation and Storage	Temperature	−40 °C to +85 °C (−40 °F to +185 °F)
	Humidity	5–95% noncondensing
Operating	Temperature	−20 °C to +50 °C (−4 °F to +122 °F)
	Humidity	5–95% noncondensing
	Altitude	Above 2000 m (6600 ft), consult factory
	Shock IEC 60068-2-27	15 G any direction for 11 milliseconds
	Vibration IEC 60068-206	5–150 Hz, 5 G, 0.7 mm maximum peak-to-peak
Pollution Degree	3	

**Table 4. Approvals and Certifications**

Electrical/EMC	Rating
ESD Immunity (IEC61000-4-2)	±8 kV Air, ±4 kV contact
Radiated Immunity (IEC61000-4-3)	10 V/m 80–1000 MHz, 80% amplitude modulation @ 1 kHz
Fast Transient (IEC61000-4-4)	±2 kV using direct method
Surge (IEC61000-4-5)	±2 kV line-to-ground
RF Conducted (IEC61000-4-6)	10 V, 0.15–80 MHz
Ingress Protection Code	IP20
Radiated and Conducted Emissions	EN55011 Class A
Agency Certifications	UL® 508
	cUL® (CSA® C22.2 No. 14)
	CE (Low Voltage Directive)

**Table 5. Input Power Supply Requirements**

Description	Requirement
Voltage Range	18–30 Vdc
Current Draw (Maximum)	30 mA

The following ratings apply to the C441QS and C441SS.

**Table 6. Environmental Ratings of the Module**

Description	Rating	
Transportation and Storage	Temperature	−40 °C to +80 °C (−40 °F to +176 °F)
	Humidity	5–95% noncondensing
Operating	Temperature	−40 °C to +55 °C (−40 °F to +131 °F)
	Humidity	5–95% noncondensing
	Altitude	Above 2000 m (6600 ft), consult factory
	Shock IEC 60068-2-27	15 G any direction for 11 milliseconds
	Vibration IEC 60068-206	10–150 Hz, 3 G, 0.3 mm maximum peak-to-peak
Pollution Degree	Pollution III	
Polar Draw	<30 mA Steady State from 24 Vdc	
Dielectric withstand	Equipment rating volts more than 50 V, potential volts AC 1000+2*V (max marked voltage)	

**Table 7. EMC Requirement**

Item	Rating
Agency Certifications	cULus by UL to UL 508, CSA C22.2 No. 14 CE (Low Voltage Directive, EMC Directive) C-TICK
Radiated and Conducted Emissions	EN 55011 Class A
<b>Electrical/EMC</b>	
ESD Immunity (IEC61000-4-2)	±8 kV Air, ±4 kV contact
Radiated Immunity (IEC61000-4-3)	10 V/m 80–1000 MHz, 80% amplitude modulation at 1 kHz
Fast Transient (IEC61000-4-4)	±2 kV supply and IO ±1 kV communications
Surge (IEC61000-4-5)	±2 kV Line to PE and ±1 kV Line-to-Line
RF Conducted (IEC61000-4-6)	10 V, 0.15–100 MHz
Magnetic Field (IEC61000-4-8)	DNA
Voltage Dips (IEC61000-4-11)	DNA
Protection Degree (IEC60947-1)	IP20

**Table 8. Input Power Supply Requirements**

Electrical/EMC	Rating
Voltage Range	18–30 Vdc
Current Draw (Maximum)	30 mA

## Ratings

**Table 9. Material Requirement**

Description	Requirement
Certification of Compliance to the EU Directive 2011/65/EU (RoHS 2.0)	Yes
Reach	Yes
PCB Laminate	Manufactured by a UL Recognized (ZPMV2) printed wiring board manufacturer, which meets the requirements in UL 508, paras. 15.1, 15.3, 36.12, & 39.4(b). CB to be marked with Vendor UL-ID code, Vendor Date Code, material, flammability rating. Polarized components shall be marked so polarity can be verified after assembly

The C441Q and C441QS provide connection for four AC input points. The ratings for these inputs are:

**Table 10. 120 Vac Input Specification**

Specification	Value
Number of Inputs	4
Voltage Category	120 Vac
Operating Range	80–140 Vac
Operating Frequency	50/60 Hz
Signal Delay Max	30 ms
Off State Voltage	0–30 Vac
On State Voltage	79–140 Vac
On State Current Max	15 mA
Supply	External Supply

The C441S and C441SS provide connection for four DC input points. The ratings for these inputs are:

**Table 11. 24 Vdc Input Specification**

Specification	Value
Number of Inputs	4
Supply Voltage	24 Vdc
Type	Current Sinking
On State Voltage	15–30 Vdc
Steady State Current Max	15 mA
Off State Voltage	0–5 Vdc
24 Vdc source current limit	50 mA
Isolation Voltage	250 Vac

The C441Q, C441S, C441QS and C441SS provide two output relays. The ratings of the relay outputs are:

**Table 12. Relay Specification**

Specification	Value
Number of Contacts	2 independent relays (one Form A, one Form C)
Thermal Contact	5 A
Rated Insulation Voltage	300 Vac
Operating Voltage	240 Vac
Operating AC Current (Rated)	3 A at 120 Vac; 1.5 A at 240 Vac
Operating DC Current (Rated)	0.24 A at 110 Vdc, 0.1 A at 220 Vdc
Min Operating Current	10 mA at 5 Vdc
Resistive Load Rating	5 A at 240 Vac, 5 A at 30 Vdc
Inductive Loading	2 A at 240 Vac, 2 A at 30 Vdc

**Table 13. Pilot Duty Relay Requirements**

Specification	Value
Pilot Duty Rating	B300
Thermal Continuous Test Current	5 A
Maximum Current (120 Vac)—Make/Break	30 A / 3 A
Maximum Current (240 Vac)—Make/Break	15 A / 1.5 A
Max VA (Volt-Amperes)—Make/Break	3600 VA / 360 VA

**Note:** Any UL Listed power supply with an isolated 24 Vdc voltage output can be used provided that a UL listed or recognized fuse rated no more than 4 A maximum is installed.

### WARNING

**Only apply 24 Vdc to the C441 communication module power supply connector. use of any other voltage may result in personal injury, property damage and damage to the module.**

## Mounting and Dimensions

### C441Q and C441S

#### Mounting

The C441 PROFIBUS adapters are designed to be installed on the right side of the Motor Insight base unit or the S611.

**Figure 1. Installation Diagram**

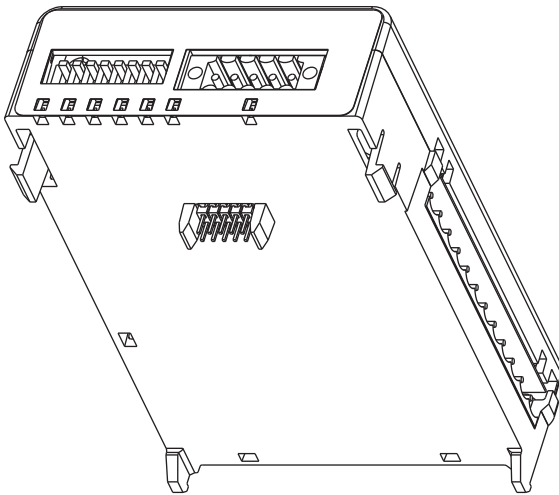

1. Align module with side of Motor Insight base unit or the S611.
2. Slide module bottom pegs into appropriate slots.
3. Rotate module up and gently click the base unit and module together.
4. Connect 24 Vdc power, PROFIBUS cable, and IO connector if desired.

**Note:** For S611 Soft Starter applications, it is recommended to mount a C441QS or C441SS module beside the S611 and wire the D0/D1 terminals between the two devices. More information on this is provided later in this document.

Dimensions

Figure 2. C441Q and C441S Product Dimensions (Attached to C441 Base Unit)

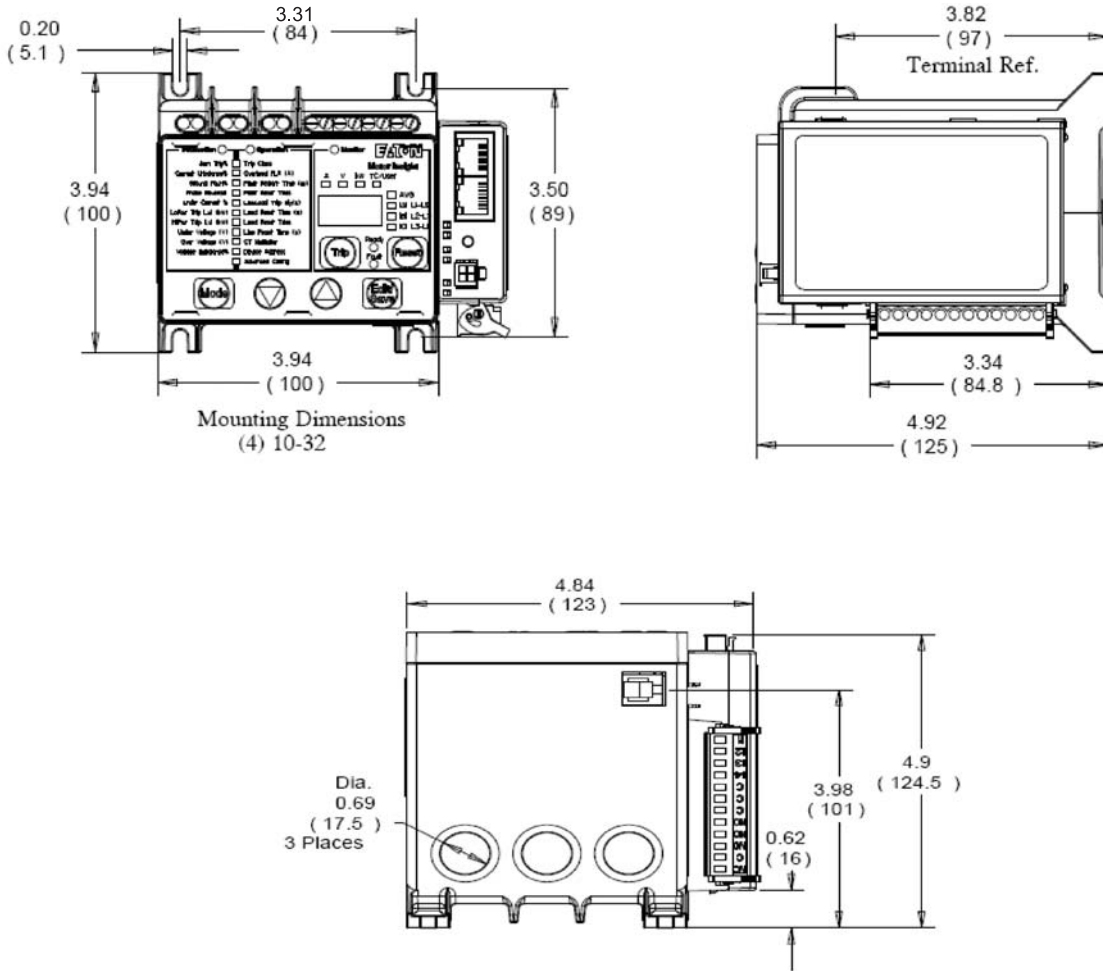

**Mounting**

**C441QS and C441SS**

The modules are designed to be installed on the DIN rail or panel surface by screw. Screw fixing dimensions reference below.

**Figure 3. Mounting of Stand-Alone Model**

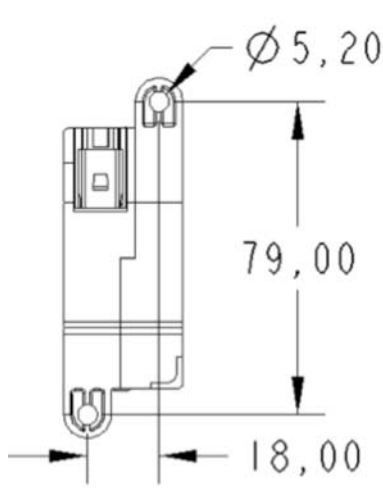

DIN rail width is 35 mm.

Dimensions

Figure 4. Stand-Alone Dimensions

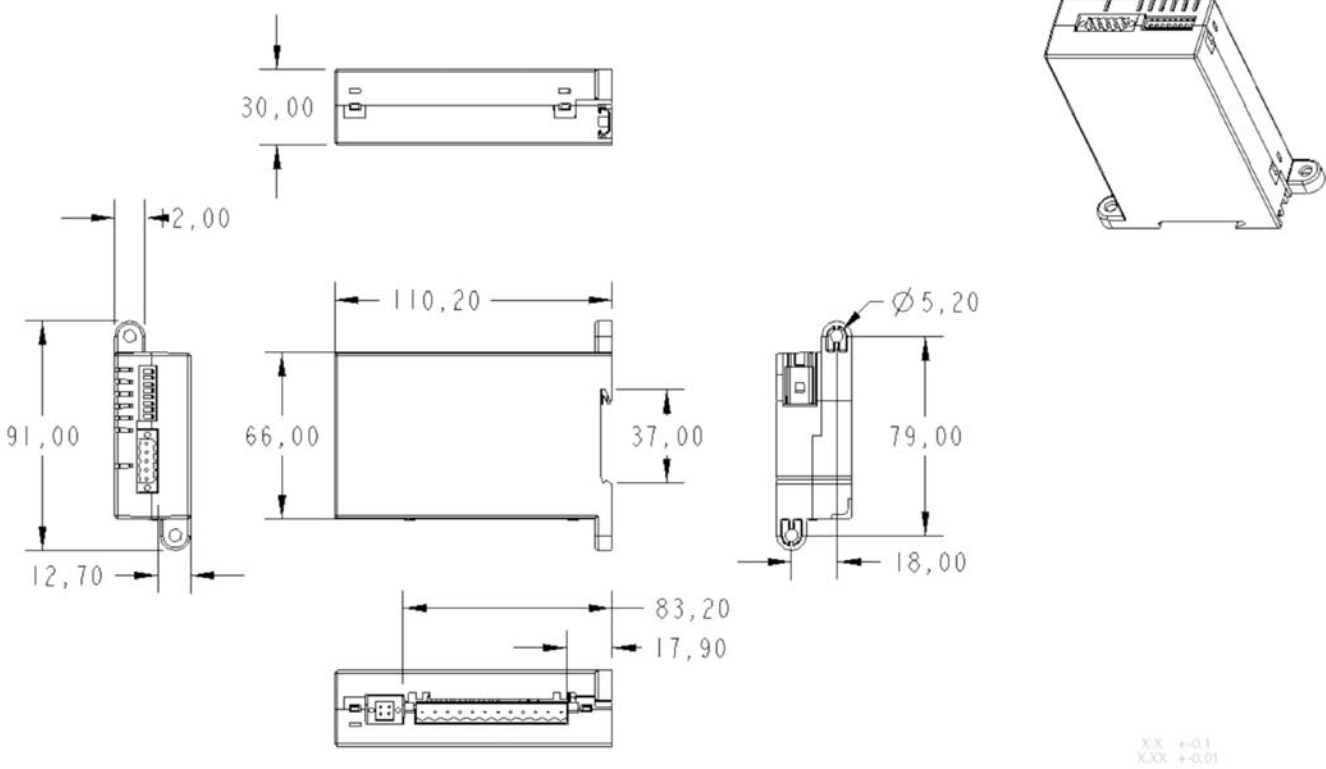

## Connections and Switch Settings

### Connecting the C441, C440, S611 and S811+ to a PROFIBUS Network

#### Connecting a C441Q/C441S to a C441 Motor Insight or S611 Soft Starter

The C441Q and the C441S modules connect to the C441 Motor Insight and S611 Soft Starter by plugging these PROFIBUS modules into the side of the C441 Motor Insight and S611. As an option, the C441QS and C441SS may also be wired to the S611 soft starter via the DO/DI terminals on each product as shown below.

#### Connecting a C441QS/C441SS to a C440 Overload, S611 Soft Starter or S811+ Soft Starter

The C441QS/SS modules communicate to the C440, S611 and S811+ by wiring the D0 terminal on the C441QS/SS to the D0 terminal on the C440, S611 and S811+ and the D1 terminal on the C441QS/SS to the D1 terminal on the C440, S611 and S811+. The C440 requires a C440-XCOM to be added to the C440 per the following. The D0/D1 terminals for the C440 are on the C440-XCOM module. All the other devices listed above have D0/D1 terminals on a connector directly attached to each product.

Figure 5. C440 to a C441QS/SS

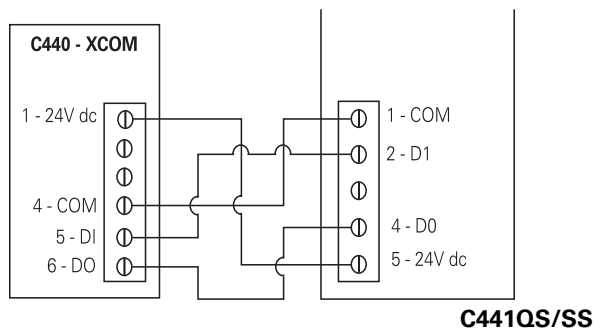
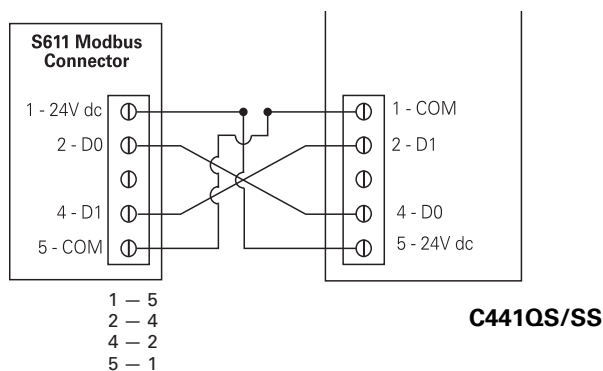

Figure 6. S611 to a C441QS/SS



### S811+ to the C441QS/SS

The D0/D1 terminals are on a separate terminal strip from where the 24 Vdc terminals are located on the S811+. Connect D0 on the S811+ to D0 on the C441QS/SS and D1 on the S811+ to D1 on the C441QS/SS.

### PROFIBUS Connection

The PROFIBUS port uses the standard DB9 PROFIBUS connection. Refer to the figure below for details on the pin out of this connector.

Figure 7. Pin Out for PROFIBUS DB9

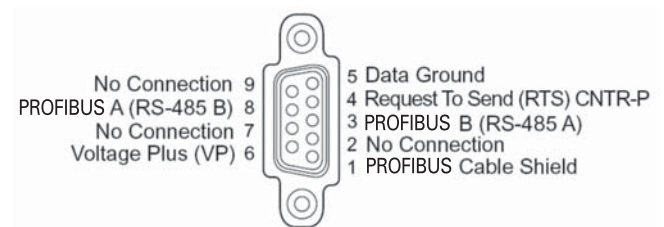

### 24 Vdc Power

The C441 PROFIBUS adapter is powered from an external 24 Vdc supply wired into the 5-pin black header (J2) located on the top of the adapter next to the 8 pos DIP switch.

**Note:** Connections to pins 2 and 4 for the C441Q/S modules are only required if Modbus communications are to be implemented.

Connections to pins 2 and 4 for the C441QS/SS are the required communication connections to interface the C440, S611 and S811+ devices to a PROFIBUS network.

Table 14. 24 Vdc Supply Connection

Pin #	Circuit	Description
1	Common	24 Vdc common input connection
2	D1	Transceiver terminal 1, V1 Voltage, Data + (V1 > V0 for binary 1 [OFF] state) Connection for Remote Modbus Port
3		NC
4	D0	Transceiver terminal 0, V0 Voltage, Data—(V0 > V1 for binary 0 [ON] state) Connection for Remote Modbus Port
5	+24 Vdc	+24 Vdc supply input connection



Figure 8. Power and Modbus RS-485 Connections

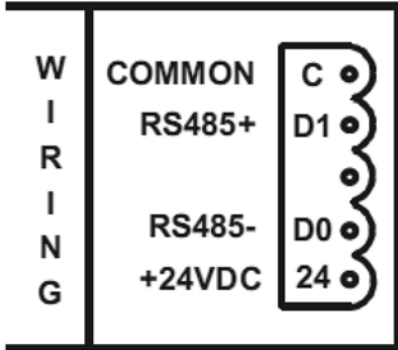

### Setting the PROFIBUS Address

#### PROFIBUS Address

The PROFIBUS address is set using the DIP switches located on the top of the C441 communication adapter. The address can only be set with the hardware DIP switches. The address is in binary with the major units numbered to the right of the switch on the label. Adding up the major units set to ON will provide the address of the adapter on the PROFIBUS network.

---

#### Notice

The address specified in the switches is only used by the adapter at the time the adapter is powered on. Changing these switches during operation will have no effect until the next power cycle or reset.

---

#### Notice

A PROFIBUS address setting of 0 will result in the C441 using the default Station Address of 125. Any PROFIBUS Station Address setting greater than 125 will result in the C441 using the default Station Address of 125.

Table 15. PROFIBUS DIP Switch Settings

DIP Switch	Value
7	64
6	32
5	16
4	8
3	4
2	2
1	1

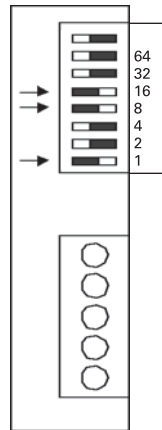

**Example:** To set a MAC ID of 25, DIP switches 5, 4, and 1 need to be turned ON, with all others OFF.

## Power and I/O Wiring Diagrams for the C441Q and C441S Modules

The C441Q module contains four 24 Vdc inputs and two relay outputs. The two relay outputs provided are one form A (NO) and one form C (NO, NC).

### 24 Vdc Inputs

The 24 Vdc input circuit is capable of both isolated and unisolated behavior. The isolated inputs share a single common tie point. A 24 Vdc current limited source/ground is provided in the situations that require locally supplied input signal voltage. To use the unisolated inputs, tie the 24 Vdc ground/common to the isolated common.

**Figure 9. C441Q: 24 Vdc Wiring Diagram**

- Example: Non-Isolated 24 Vdc Input Source**
- Input source power is taken from the 5-pin connector.
  - Connect C and 0V together.
  - Use 24 to source inputs.

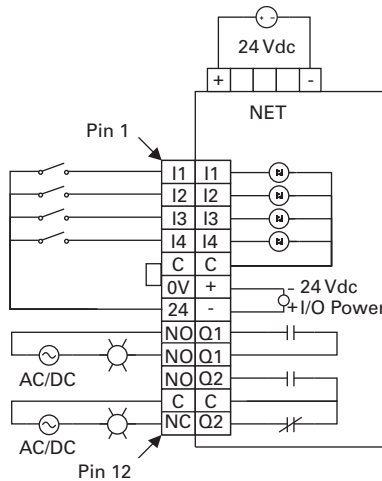

- Example: Isolated 24 Vdc Input Source**
- The inputs must be supplied by an external power source.
  - Do not connect the external supply to terminals 0V and 24.
  - Connect isolated power source between C and Inputs.

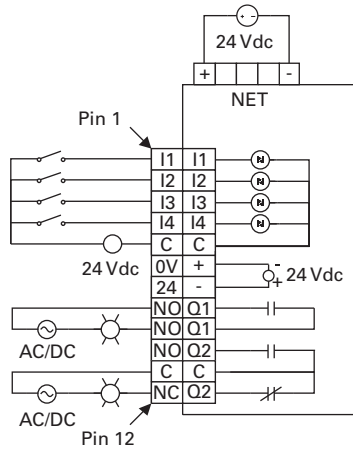

**Note:** Do not connect a 24 Vdc source to pins 6 and 7. The "I/O Power: 24 Vdc" is to be used only in conjunction with the inputs. It is a 24 Vdc output intended to only supply signal power for the inputs. When using the 24 Vdc input supply, pin 6 should only be connected to pin 5 (24 Vdc input supply common to input common). See example wiring diagram above. Any device using the provided 24 Vdc input supply must have 500 V isolation from ground. Example devices include pushbuttons and auxiliary contacts.

## Connections and Switch Settings

The C441S module contains four 120 Vac inputs and two relay outputs. The two relay outputs provided are one form A (NO) and one form C (NO, NC).

**Figure 10. C441S: 120 Vac Wiring Diagram**

Example 120 Vac IO Module

- All inputs are isolated.
- All Common terminals are connected together internally.

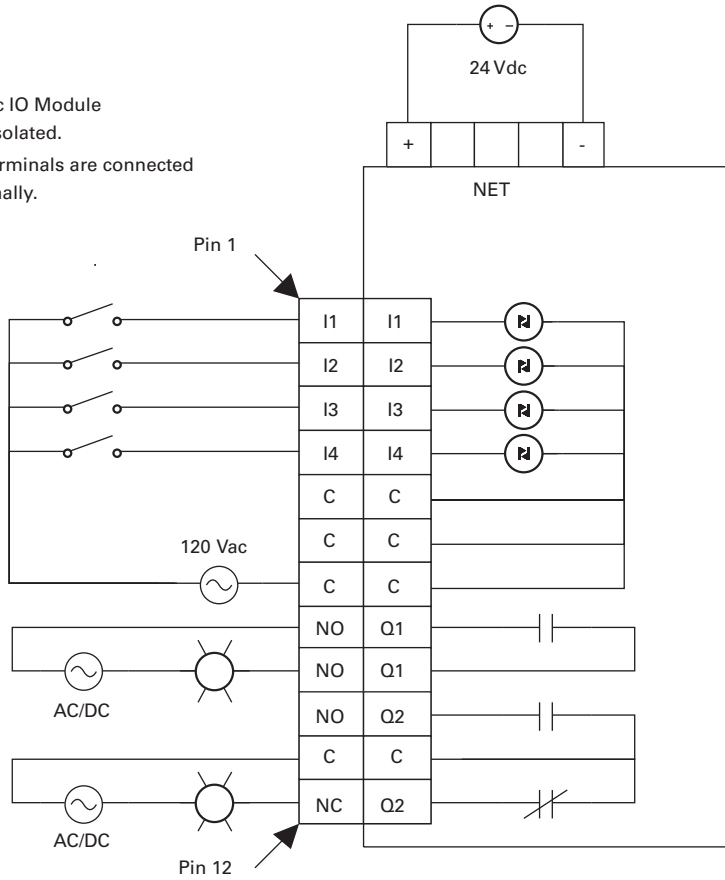

### Power and I/O Wiring Diagrams for the C441QS and C441SS Modules

The C441QS module contains four 24 Vdc inputs and two relay outputs. The two relay outputs provided are one form A (NO) and one form C (NO, NC).

**Figure 11. C441QS – 24 Vdc Input Specification**

- Example: Non-isolating 24 Vdc input source
- Input source power is taken from 5-pin connector
  - Connect C and OV together
  - Use 24 to source inputs

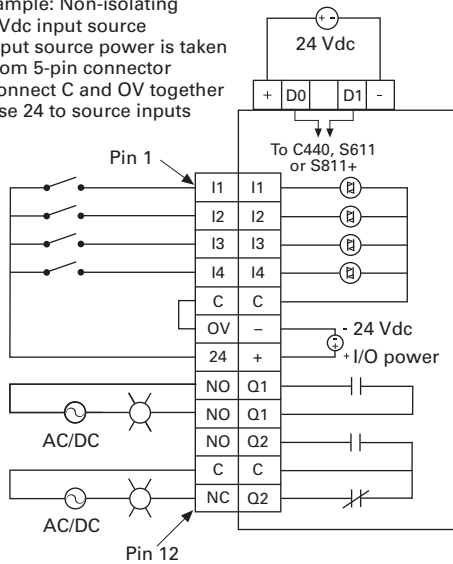

- Example: Isolated 24 Vdc input source
- The inputs must be supplied by an external power source
  - Do not connect the external supply to terminals OV and 24
  - Connect isolated power source between C and inputs

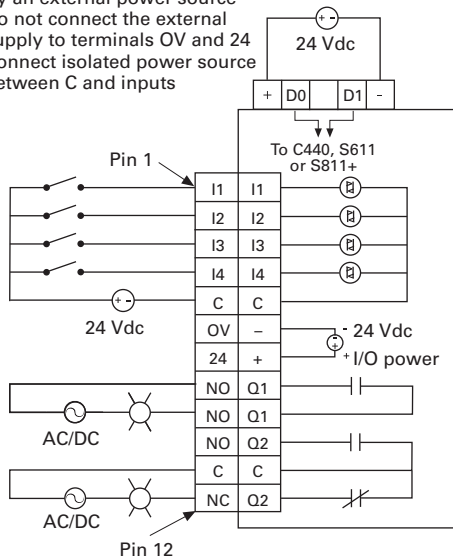

### 24 Vdc Inputs

The 24 Vdc input circuit is capable of both isolated and unisolated behavior. The isolated inputs share a single common tie point. A 24 Vdc current limited source/ground is provided in the situations that require locally supplied input signal voltage. To use the unisolated inputs, tie the 24 Vdc ground/common to the isolated common.

The C441SS module contains four 120 Vac inputs and two relay outputs. The two relay outputs provided are one form A (NO) and one form C (NO, NC).

**Figure 12. C441SS – 120 Vac Input Specification**

- Example: 120 Vac IO module
- All inputs are isolated
  - All common terminals are connected together internally

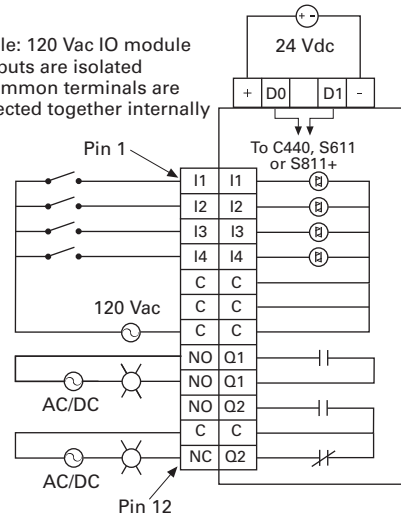

## PROFIBUS Status Indicators

### PROFIBUS Status LEDs

There are three LED indicators (ON, BF, and SF) to clarify the working state of the PROFIBUS module/network.

**Table 16. PROFIBUS Status LEDs**

ON (GREEN, the left one)	BF (RED, the middle one)	SF (RED, the right one)	Fault Condition
ON	OFF	OFF	Everything OK
ON	ON	OFF	No communication
ON	Blinking	OFF	Communication, but not in data exchange
ON	ON	ON	Configuration not OK

### Connecting and Disconnecting a C441 PROFIBUS Module from the C440, C441, S611, S811+ or as a Stand-Alone I/O Module

A C441 PROFIBUS module will work with whatever device it is connected to out-of-box, C440, C441, S611, S811+ or as a stand-alone I/O module.

If a C441 PROFIBUS module has previously been connected to one device type and then needs to be connected to another device type, the following procedure must be performed.

1. Disconnect the C441 PROFIBUS module from the existing device.
2. Set the DIP switches on the C441 PROFIBUS module to a value of three per **Figure 13**.
3. Toggle the top switch shown in **Figure 13** 5 times (off-on-off is one cycle). A reset will occur after the fifth cycle indicated by all LEDs turning ON, then OFF again. Turn power off to the module.
4. Connect the C441 PROFIBUS module to the new device or use it as a stand-alone I/O module. When it is powered up again, it will begin working with the new device or as a stand-alone I/O module.

**Figure 13. DIP Switch Service 3 Example**

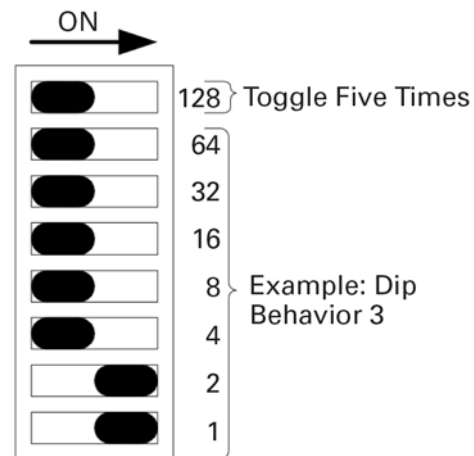

## Configuration Using the PROFIBUS Configuration File

The C441 PROFIBUS adapters give the user the ability to enable/disable protections, set up trip thresholds, set up trip delays, and reset delays for the C441 Motor Insight relay, the C440 Overload relay, the S611 Soft Starter and the S811+ Soft Starter over a PROFIBUS network.

Upon reception of the parameterization telegram, device parameter data is range checked. If the data is outside the range specified in the GSD file, the parameterization will be rejected and parameterization will fail. Data for parameters such as Overload FLA, Low kW Trip Level, High kW Trip Level, and GND Fault Trip Level whose ranges vary based on model will be “adjusted.” If the value is greater than the maximum allowed value, the parameter is set to its maximum value. Likewise, if a parameter is set to a value less than its minimum value, the parameter will be set to its minimum value.

**Note:** Values must still fall within the range specified in the GSD file for parameterization to be successful.

---

### Notice

---

The “Enable Device Parameterization” parameter must be enabled for the connected device parameters to be downloaded into the device. If the “Enable Device Parameterization” parameter is set to “Ignore” (0), device parameters are “ignored” by the C441 PROFIBUS adapter and are not downloaded into the connected device.

## C441 Motor Insight Overload Protection Relay

**Table 17. C441 Motor Insight Configuration File**

Parameter Name	Location	Notes
Enable Device Parameterization	Adapter	0 = Ignore user data, 1 = Download Device Parameters
Com Adapter Outputs ComLoss Behavior	Adapter	0 = Fail Safe (outputs disabled), 1 = Hold Last state
CT Multiplier	Motor Insight	Cat No C441BB, C441CB, C441DB 1-4 Cat No C441BA, C441CA, C441DA 1, 2, 3 (150:5), 4 (300:5), 5 (600:5)
Overload FLA	Motor Insight	Setting is in Amps x 100 Cat No C441BB, C441CB, C441DB 5–22.5 Amps (CT Multiplier = 4) 6.67–30 Amps (CT Multiplier = 3) 10–45 Amps (CT Multiplier = 2) 20–90 Amps (CT Multiplier = 1) Cat No C441BA, C441CA, C441DA 1–5 Amps (CT Multiplier = 2) 2–9 Amps (CT Multiplier = 1) 60–135 Amps (CT Multiplier = 3) 120–270 Amps (CT Multiplier = 4) 240–540 Amps (CT Multiplier = 5)
Overload Trip Class	Motor Insight	5–30
Overload Reset Mode	Motor Insight	0 = manual reset mode—default 1 = Apply Motor Fault Reset Delay and Motor Faults Number of Restarts
Over Voltage Trip Enable	Motor Insight	1 = Trip Enabled; 0 = Warning only
Under Voltage Trip Enable	Motor Insight	1 = Trip Enabled; 0 = Warning only
Phase Order Trip Enable	Motor Insight	1 = Trip Enabled; 0 = Warning only
GND Fault Trip Enable	Motor Insight	1 = Trip Enabled; 0 = Warning only
Voltage Unbalance Trip Enable	Motor Insight	1 = Trip Enabled; 0 = Warning only
Current Unbalance Trip Enable	Motor Insight	1 = Trip Enabled; 0 = Warning only
Under Current Trip Enable	Motor Insight	1 = Trip Enabled; 0 = Warning only
Phase Loss Trip Enable	Motor Insight	1 = Trip Enabled; 0 = Warning only
Jam Trip Enable	Motor Insight	1 = Trip Enabled; 0 = Warning only
Low kW Trip Enable	Motor Insight	1 = Trip Enabled; 0 = Warning only
High kW Trip Enable	Motor Insight	1 = Trip Enabled; 0 = Warning only
GND Fault Trip Level	Motor Insight	Setting in Amps x 100 Cat No C441BB, C441CB, C441DB 3–20 A (CT Multiplier = 1) 1.5–10 (CT Multiplier = 2) 1–6.66 (CT Multiplier = 3) 0.75–5 (CT Multiplier = 4) Default setting is 10 A Cat No C441BA, C441CA, C441DA 0.3–2.0 A (CT Multiplier = 1) 0.15–1.0 (CT Multiplier = 2) 9–60 (CT Multiplier = 3) 18–120 (CT Multiplier = 4) 36–240 (CT Multiplier = 5) Default setting is 1 A
GND Fault Trip Delay	Motor Insight	1–60 seconds (30) default

**Table 17. C441 Motor Insight Configuration File, continued**

Parameter Name	Location	Notes
GND Fault Trip Mode	Motor Insight	0 = Trip on GND fault 1 = Alarm-no-trip—default
Under Current Trip Level	Motor Insight	10–90% of FLA (50) default
Under Current Trip Delay	Motor Insight	1–60 seconds (5) default
Low Power Trip Level	Motor Insight	Setting is in kW x 100 Default value is the minimum value in the range.
Low Power Trip Delay	Motor Insight	1–60 seconds (5) default
High Power Trip Level	Motor Insight	Setting is in kW x 100 Default value is the minimum value in the range.
High Power Trip Delay	Motor Insight	1–60 seconds (5) default
% Current Unbalance Trip Level	Motor Insight	1–30% (15%) default
Current Unbalance Trip Delay	Motor Insight	1–20 seconds (10) default
Under Voltage Trip Level	Motor Insight	170–264 V (216 V) CC441BA, C441BB 323–528 V (432 V) C441CA, C441CB 489–660 V (540 V) C441DA, C441DB
Under Voltage Trip Delay	Motor Insight	1–20 seconds (10) default
Over Voltage Trip Level	Motor Insight	170–264 V (264 V) C441BA, C441BB 323–528 V (528 V) C441CA, C441CB 489–660 V (540 V) C441DA, C441DB
Over Voltage Trip Delay	Motor Insight	1–20 seconds (10) default
% Voltage Unbalance Trip Level	Motor Insight	1–20% (6%) default
Voltage Unbalance Trip Delay	Motor Insight	1–20 seconds (10) default
Voltage Faults Trip Mode	Motor Insight	0 = Trip on voltage fault 1 = Alarm-no-trip (inhibit start)—default
Jam Fault Trip Level	Motor Insight	150–400% of FLA (300%) default
Jam Fault Trip Delay	Motor Insight	1–60 seconds (5) default
Phase Loss Trip Delay	Motor Insight	1–20 seconds (10) default
Restart Delay	Motor Insight	0–500 seconds (10) default
Motor Fault Reset Delay	Motor Insight	2–500 minutes (8) default
Motor Faults—Number of Restarts	Motor Insight	0 = Manual, 1–4, 5 = Auto reset mode
Load Faults Reset Delay	Motor Insight	2–500 minutes (20) default
Load Faults—Number of Restarts	Motor Insight	0 = Manual, 1–4, 5 = Auto reset mode
Enable Load Faults Reset Delay Auto Calculator	Motor Insight	0 = Reset Delay Auto Calc Off 1 = Reset Delay Auto Calc On
Run Transition % of FLA	Motor Insight	25–125%
Run Transition Time	Motor Insight	1–180 seconds
Phase Order	Motor Insight	0x0000 = Phase Order Trip Disabled 0x0001 = ACB Phase Order 0x0002 = ABC Phase Order
MI ComLoss Timeout	Motor Insight	0 = 65000 (msec)
MI ComLoss Behavior	Motor Insight	0x0001 = Fault (Fail Safe) Relay Off 0x0002 = Hold Last State
Enable MI AuxRly GND Trip Indication	Motor Insight	1 = Indication Enabled; 0 = No Indication (CP models only)
Enable MI AuxRly V Unbal Indication	Motor Insight	1 = Indication Enabled; 0 = No Indication (CP models only)
Enable MI AuxRly I Unbal Indication	Motor Insight	1 = Indication Enabled; 0 = No Indication (CP models only)
Enable MI AuxRly Under I Indication	Motor Insight	1 = Indication Enabled; 0 = No Indication (CP models only)



**Table 17. C441 Motor Insight Configuration File, continued**

Parameter Name	Location	Notes
Enable MI AuxRly PhLoss Trip Indication	Motor Insight	1 = Indication Enabled; 0 = No Indication (CP models only)
Enable MI AuxRly Jam Trip Indication	Motor Insight	1 = Indication Enabled; 0 = No Indication (CP models only)
Enable MI AuxRly LowKW Trip Indication	Motor Insight	1 = Indication Enabled; 0 = No Indication (CP models only)
Enable MI AuxRly HighKW Trip Indication	Motor Insight	1 = Indication Enabled; 0 = No Indication (CP models only)
Enable MI AuxRly HighV Trip Indication	Motor Insight	1 = Indication Enabled; 0 = No Indication (CP models only)
Enable MI AuxRly LowV Trip Indication	Motor Insight	1 = Indication Enabled; 0 = No Indication (CP models only)
Enable MI AuxRly PhRev Trip Indication	Motor Insight	1 = Indication Enabled; 0 = No Indication (CP models only)
Enable MI AuxRly Overload Indication	Motor Insight	1 = Indication Enabled; 0 = No Indication (CP models only)
Enable MI AuxRly Freq Fault Indication	Motor Insight	1 = Indication Enabled; 0 = No Indication (CP models only)
MI AuxRly Reset Delay	Motor Insight	0 = 500 (minutes) (CP models only)
MI-CP-HVR Wire Config	Motor Insight	Three-phase, single-phase V and I or Three-phase current only (CP models only)
MI-CP-HVR Overload on Start	Motor Insight	Enable/Disable (CP models only)
MI-CP-HVR GF on Start	Motor Insight	Enable/Disable (CP models only)
MI-CP-HVR Anti-back spin Time	Motor Insight	0–3600 seconds (CP models only)
MI-CP-HVR PT Ratio	Motor Insight	0–8000 (CP models only)

## C440 Overload Protection Relay

**Table 18. C440 Overload Supported Configuration File**

Parameter Name	Location	Notes
Enable Device Parameterization	Adapter	0 = Ignore user data 1 = Download Device Parameters
Com Adapter Outputs Com Loss Behavior	Adapter	0 = Fail Safe (Off) 1 = Hold Last State
C440 Com Loss Behavior	C440	Fault/Hold Last State

## S611 Soft Starter

**Table 19. S611 Soft Starter Configuration File**

Parameter Name	Location	Notes
<b>Extended User Parameter Data</b>		
Enable Device Parameterization	Adapter	0 = Ignore user data, 1 = Download Device Parameters
Com Adapter Outputs ComLoss Behavior	Adapter	0 = Fail Safe (outputs disabled), 1 = Hold Last state
Overload FLA	S611	Motor full load amp rating (in 0.1A)
Overload Trip Class	S611	Trip class 5, 10, 20, & 30
Start Method	S611	Voltage ramp start Current limit start Pump start
Start Time	S611	Length of start in 0.1 sec. (5–1800)
Initial Torque	S611	Initial starting torque applied to motor at beginning of the start profile. (0–100%)
Stop Time*	S611	Length of stop ramp in 0.1 sec. (0–600) 0 sec = disabled
Pump Stop Time*	S611	Length of pump stop ramp in 0.1sec. (50–1200)
Kick Start Time	S611	Length of time to apply kick torque in 0.1 sec. (0–20) Setting time to 0sec disables kick torque setting.
Kick Start Torque	S611	Kick torque applied to motor at beginning of the start profile. (0–100%). Only
Motor Rated Voltage	S611	Nameplate Rated motor voltage. (115–600 V)
Under Voltage Percent	S611	Under voltage fault threshold. (% rated motor voltage) (1–99%)
Under Voltage Trip Delay	S611	Length of under voltage condition before fault in sec. (0–20)
Over Voltage Percent	S611	Over voltage fault threshold. (% rated motor voltage) (101–120%)
Over Voltage Trip Delay	S611	Length of over voltage condition before fault in sec. (0–20)
Voltage Imbalance Percent	S611	Voltage Imbalance fault threshold. (% rated motor voltage) (1–20%)
Voltage Imbalance Trip Delay	S611	Length of voltage imbalance condition before fault in sec. (0–20)
Phase Sequence	S611	Incoming voltage phase sequence ABC ACB
Reset Mode	S611	Fault Reset mode Manual Reset Auto Reset
Enable Overload trip	S611	0 = disable fault 1 = enable fault
Enable Jam trip	S611	0 = disable fault 1 = enable fault
Enable Stall trip	S611	0 = disable fault 1 = enable fault
Enable Current Imbalance	S611	0 = disable fault 1 = enable fault
Enable Load Disconnect trip	S611	0 = disable fault 1 = enable fault
Enable Phase Loss trip	S611	0 = disable fault 1 = enable fault
Enable Under Voltage trip	S611	0 = disable fault 1 = enable fault
Enable Over Voltage trip	S611	0 = disable fault 1 = enable fault
Enable Voltage Imbalance trip	S611	0 = disable fault 1 = enable fault

## Configuration Using the PROFIBUS Configuration File

**Table 19. S611 Soft Starter Configuration File, continued**

Parameter Name	Location	Notes
Enable Phase Reversal trip	S611	0 = disable fault 1 = enable fault
Enable Overload on start trip	S611	0 = disable fault 1 = enable fault
Enable Shorted SCR trip	S611	0 = disable fault 1 = enable fault
Enable SCR Not Firing trip	S611	0 = disable fault 1 = enable fault
Enable Over Temp trip	S611	0 = disable fault 1 = enable fault
Enable GND Fault trip	S611	0 = disable fault 1 = enable fault
Jam Trip Level	S611	Current threshold setting for Jam fault. (valid only during bypass 150–400% rated motor fla)
Jam Trip Delay	S611	Length of jam condition before fault in sec. (1–20)
Stall Trip Level	S611	Current threshold setting for Stall fault. (valid only at end of start ramp 150–300% rated motor fla)
Residual GF Trip Level	S611	Current threshold setting for GND fault trip. (in 0.1A) (1–100)
Residual GF Trip Delay	S611	Length of GND fault condition before fault in sec. (1–20)
Residual GF Start Delay	S611	Length of time from start to mask fault. (0–20sec)
Current Unbalance Trip Level	S611	Current Imbalance fault threshold. (1–20%)
Current Unbalance Trip Delay	S611	Length of current imbalance condition before fault. (1–20sec)
Load Disconnect Trip Level	S611	Load disconnect fault threshold. (% motor fla: 1–50%)
Load Disconnect Trip Delay	S611	Length of load disconnect condition before fault. (1–60sec)
Load Disconnect Source	S611	Low Power Low Current
Phase Loss Trip Level	S611	Phase loss fault threshold. (% motor fla: 0–100%)
Phase Loss Trip Delay	S611	Length of phase loss condition before fault. (1–20sec)
Start Control Level or Edge	S611	S611 input configuration 0 = Edge triggered inputs 1 = Level triggered inputs
Fault Relay Configuration	S611	S611 fault relay configuration—relay output enabled when: 0 = Faulted 1 = Not Faulted
Aux Relay Configuration	S611	S611 aux relay configuration—relay output enable when: 0 = Faulted 1 = Not Faulted 2 = in Bypass 3 = Not in Bypass 4 = Motor Energized 5 = Not Motor Energized
User UI Edit Lock	S611	Lock S611 User interface module. (Prohibits changing S611 settings from UI) 0 = unlocked 1 = locked
Comm loss Timeout in milli-seconds	S611	Length of comloss before fault. (in .001 sec: 1–65000)
Comm loss behavior	S611	1 = Fault 2 = Hold Last State 3 = Stop
S611 ComLoss Enable	S611	0 = disable fault 1 = enable fault

## S811+ Soft Starter

**Table 20. S811+ Soft Starter Configuration File**

Parameter Name	Location	Notes
Enable Device Parameterization	Adapter	0 = Ignore user data 1 = Download Device Parameters
Com Adapter Outputs Com Loss Behavior	Adapter	0 = Fail Safe (outputs disabled) 1 = Hold Last State
Overload Trip FLA Value scaled in 0.1A	S811+	110–20,000 range
Overload Trip Class Value	S811+	Class 5–30
Motor Rated Volts	S811+	115–600 V (Motor nameplate voltage)
Motor Line Frequency Rating	S811+	50.00–60.00 Hz (in 0.01 Hz)
Motor Wiring Configuration	S811+	0 = Inline Wiring 1 = Inside Delta
Motor Phase Sequence	S811+	0 = ABC Phase sequence 1 = ACB Phase sequence
Motor Start Method	S811+	0 = Voltage Ramp 1 = Current Limit 2 = Unavailable 3 = Pump Start (w pump option)
Percent Initial Torque	S811+	0–100%
Motor Start Ramp Time	S811+	0.5–180 s (in 0.1 sec)
Motor Stop Ramp Time	S811+	0.0–60.0 s (in 0.1 sec)
Motor Pump Stop Time	S811+	20.0–120.0 (in 0.1 sec)
Kick Start Initial Torque	S811+	0–100%
Kick Start Time	S811+	0.0–2.0 sec (in 0.1 sec)
Ramp2 Motor Phase Sequence	S811+	0 = ABC Phase sequence 1 = ACB Phase sequence
Ramp2 Motor Start Method	S811+	0 = Voltage Ramp 1 = Current Limit 2 = Unavailable 3 = Pump Start (w pump option)
Ramp2 Motor Percent Initial Torque	S811+	0–100%
Ramp2 Motor Start Ramp Time	S811+	0.5–180 s (in 0.1 sec)
Ramp2 Motor Stop Ramp Time	S811+	0.0–60.0 s (in 0.1 sec)
Ramp2 Motor Pump Stop Time	S811+	20.0–120.0 (in 0.1 sec)
Ramp2 Motor Kick Start Initial Torque	S811+	0–100%
Ramp2 Motor Kick Start Time	S811+	0.0–2.0 sec (in 0.1 sec)
Motor Control Terminal Block Local Control Enable	S811+	1 = local control only enabled 0 = disable (terminal block input selects local/network control)

## Configuration Using the PROFIBUS Configuration File

**Table 20. S811+ Soft Starter Configuration File, continued**

Parameter Name	Location	Notes
Motor Control Input Configuration	S811+	0 = No function 1 = Run1 2 = Ramp2 3 = Jog 4 = Local control enable 5 = Fault reset 6 = E-stop input 7 = Alarm-No-Trip 8 = External Trip 9 = External Warning 10 = Disable overload on start 11 = Analog Input (S811 input #4 only)
S811 input#1 cfg 2 bytes		
S811 input#2 cfg 2 bytes		
S811 input#3 cfg 2 bytes		
S811 input#4 cfg 2 bytes		
Network input#1 cfg 2 bytes		
Network input#2 cfg 2 bytes		
Network input#3 cfg 2 bytes		
Network input#4 cfg 2 bytes		
Analog Input Data Range	S811+	<b>Value Description</b> 0x01 not supported 0x02 0–20 mA range 0x03 4–20 mA range
Motor Control Output Configuration	S811+	0 = No function 1 = Faulted 2 = Not Faulted 3 = Bypass 4 = Not Bypass 5 = Motor Energized 6 = Motor Not Energized 7 = Warning 8 = Not Warning 9 = Custom Codes 10 = Not Custom Codes
S811 output#1 cfg 2 bytes		
S811 output#2 cfg 2 bytes		
Network output#1 cfg 2 bytes		
Network output#2 cfg 2 bytes		
Fault Reset Mode	S811+	0 = Manual reset 1 = Auto reset 2 = Power on reset
Auto Reset Delay Time	S811+	0.1–600.0 sec (in 0.1 sec)
Auto Reset Number of Reset Attempts Limit	S811+	0–10000
Overload Fault Enable	S811+	0 = Protection disabled 1 = Fault enabled 2 = Warning enabled
Motor Overload During Start Enable	S811+	1 = enable 0 = disable
Phase Reversal Fault Enable	S811+	0 = Protection disabled 1 = Fault enabled 2 = Warning enabled
Motor Undercurrent Fault (Warning) Trip Enable	S811+	0 = Protection disabled 1 = Fault enabled 2 = Warning enabled
Motor Undercurrent Fault Trip Level (% FLA)	S811+	0–100%
Motor Undercurrent Fault Duration	S811+	0.1–60.0 sec (in 0.1 sec)
Motor Jam Fault Enable	S811+	0 = Protection disabled 1 = Fault enabled 2 = Warning enabled
Motor Stall Fault Enable	S811+	0 = Protection disabled 1 = Fault enabled 2 = Warning enabled
Motor Phase Loss Fault Enable	S811+	0 = Protection disabled 1 = Fault enabled 2 = Warning enabled

**Table 20. S811+ Soft Starter Configuration File, continued**

Parameter Name	Location	Notes
Motor Phase Loss Trip Level	S811+	1–100%
Motor Phase Loss Duration	S811+	0.1–60.0 sec (in 0.1 sec)
Motor Phase Imbalance Fault Enable	S811+	0 = Protection disabled 1 = Fault enabled 2 = Warning enabled
Motor Phase Imbalance Fault Level	S811+	1–100%
Motor Phase Imbalance Fault Duration	S811+	0.1–60.0 sec (in 0.1 sec)
Motor Voltage Imbalance Fault Level	S811+	1–100%
Motor Voltage Imbalance Fault Duration	S811+	0.1–60.0 sec (in 0.1 sec)
Motor Under Voltage Fault Enable	S811+	0 = Protection disabled 1 = Fault enabled 2 = Warning enabled
Motor Under Voltage Fault (% of Rated Voltage)	S811+	1–99%
Motor Under Voltage Fault Duration (Running)	S811+	0.1–60.0 sec (in 0.1 sec)
Motor Over Voltage Fault Enable	S811+	0 = Protection disabled 1 = Fault enabled 2 = Warning enabled
Motor Over Voltage Fault (% of Rated Voltage)	S811+	101–120%
Motor Over Voltage Fault Duration	S811+	0.1–60.0 sec (in 0.1 sec)
Motor Line Frequency Fault (Warning) Enable, Len=1	S811+	0 = Protection disabled 1 = Fault enabled 2 = Warning enabled
Motor Line Frequency Deviation From Rated Fault Level	S811+	0–100% deviation from setting
Motor Line Frequency Fault Duration	S811+	0.1–60.0 sec (in 0.1 sec)
Motor Average Power Fault (Warning) Enable	S811+	0 = Protection disabled 1 = Fault enabled 2 = Warning enabled
Motor Average Power Percent Rated Low Fault Level	S811+	0.0–100.0% (in 0.1%)
Motor Average Power Percent Rated High Fault Level	S811+	0.0–800.0% (in 0.1%)
Motor Average Power Fault Duration	S811+	0.1–60.0 sec (in 0.1 sec)
Analog Input Fault (Warning) Enable	S811+	0 = Protection disabled 1 = Fault enabled 2 = Warning enabled
Analog Input Percent of Rated Range Low Fault Level	S811+	0–100% (of range)
Analog Input Percent of Rated Range High Fault Level	S811+	0–100% (of range)
Analog Input Fault Duration	S811+	0.1–60.0 sec (in 0.1 sec)
Temperature Sensor Fault Enable	S811+	0 = Protection disabled 1 = Fault enabled 2 = Warning enabled
SCR Not Firing Fault Enable	S811+	0 = Protection disabled 1 = Fault enabled 2 = Warning enabled
SCR Shorted Fault Enable	S811+	0 = Protection disabled 1 = Fault enabled 2 = Warning enabled
Alarm No Trip Enable	S811+	1 = enable 0 = disable

**Table 20. S811+ Soft Starter Configuration File, continued**

<b>Parameter Name</b>	<b>Location</b>	<b>Notes</b>
Motor Control Start Delay Warning Enable	S811+	1 = enable 0 = disable
Motor Control Power on Start Delay	S811+	0.0–600.0 sec (in 0.1 sec)
Motor Control Start Delay	S811+	0.0–600.0 sec (in 0.1 sec)
Motor Control Run Command Change Start Delay	S811+	0.0–600.0 sec (in 0.1 sec)
Motor Ground Fault (Warning) Enable	S811+	0 = Protection disabled 1 = Fault enabled 2 = Warning enabled
Motor Ground Fault Inhibit from Start Delay	S811+	0–200

## PROFIBUS I/O Parameters

### Cyclic IO Data for C441, C440, S611, S811+ and Stand-Alone I/O

There is a different Base Module that must be entered into the Base Module Slot in a PROFIBUS master's software for each of the devices the C441 PROFIBUS modules interface to the PROFIBUS network. The Base modules are defined in the GSD file for the C441Q/S/QS/SS. The default Base module is the "IO StandAlone Base". The other Base Modules are as follows:

- C441 Motor Insight Base
- C440 Overload Base
- S611 Soft Starter Base
- S811 Soft Starter Base

By default, the first 2 Data Exchange Module slots, from the GSD file contain the following:

- Com Adapter Outputs\_1
  - Control for the 2 outputs on the C441Q/S/QS/SS module
- Com Adapter Inputs\_1
  - Status of the 4 inputs on the C441Q/S/QS/SS module

These first 2 modules are used with all Base Modules. A third parameter may also be used with all of the Base modules: "Com Adapter Status". Following the first 2 parameters are the optional data shown below for each supported device, based on the Base Module used. If the IO StandAlone Base is used, only the COM Adapter Outputs\_1, Com Adapter Inputs\_1 and Com Adapter Status Data Exchange Parameters may be used.



## C441 Motor Insight Overload Protection Relay

**Table 21. C441 Motor Insight Available IO Data for Cyclic Polling**

IO	Size (in bytes)	Configuration Modules	Notes
N/A	0	C441 Motor Insight Base	Base module for C441 Motor Insight protective relay. <b>Note:</b> Base module must be loaded into slot 1 of the configuration. This MUST be the first module listed in the configuration.
output	1	Com Adapter Outputs	0x01 = Turn on Relay1 0x02 = Turn on Relay2
input	1	Com Adapter Inputs	0x01 = I0 enabled 0x02 = I1 enabled 0x04 = I2 enabled 0x08 = I3 enabled
input	1	Com Adapter Status	0x0001 = Adapter Connected 0x0002 = Message Error 0x0004 = Adapter Married
output	2	MI Configuration Reset	0x0001 = Soft Reset (power cycle) 0x0002 = Factory Reset <b>Note:</b> Configuration reset will clear after write
output	2	MI Command Register	0x0066 = Clear Motor Run Hours 0x0077 = Clear Fault Queue 1 0x0078 = Clear Fault Queue 0x0088 = Network watchdog enable 0x0099 = Network watchdog disable 0x00AA = Reset Relay 0x00BB = Clear Motor Start Count 0x00CC = Force Ground Fault 0x00DD = Relay OFF <b>Note:</b> Command register will clear after write
input	2	MI Run-Time	Hours (Run Time can be reset via the MI Command Register)
input	2	MI Start Count	Start Count can be reset via the MI Command Register

**Table 22. C441 Motor Insight Available IO Data for Cyclic Polling (PROFIBUS)**

IO	Size (in bytes)	PROFIBUS IO Modules	Notes
input	2	MI RMS Current I1	Scaled current (0.01 amps)
input	2	MI RMS Current I2	Scaled current (0.01 amps)
input	2	MI RMS Current I3	Scaled current (0.01 amps)
input	2	MI RMS Current Ave	Scaled current (0.01 amps)
input	2	MI RMS Voltage L1-L2	Volts
input	2	MI RMS Voltage L2-L3	Volts
input	2	MI RMS Voltage L3-L1	Volts
input	2	MI RMS Voltage Average	Volts
input	2	MI Total Kilowatts	kW x 100
input	2	MI Voltage Unbalance Percentage	Max Deviation from Ave / Ave) x 100
input	2	MI Current Unbalance Percentage	Max Deviation from Ave / Ave) x 100
input	2	MI Apparent Power Factor	Power Factor x 100 (inductive 0–100)
input	2	MI Residual GND I (deciamps)	Amps x 100
input	2	MI Line frequency	Hz x 100
input	2	MI Thermal Pile Percentage	0% cold, 100% = overload trip (0–255)
input	20	MI Active Fault Queue	Last 10 faults
input	2	MI Supply Flt-Remaining Rstart Dly	Seconds remaining before fault can be reset

**Table 22. C441 Motor Insight Available IO Data for Cyclic Polling (PROFIBUS), continued**

<b>IO</b>	<b>Size (in bytes)</b>	<b>PROFIBUS IO Modules</b>	<b>Notes</b>
input	2	MI Load Flt-Remaining Rstart Dly	Seconds remaining before fault can be reset
input	2	MI Load Flt-Remaining Rstart Dly	Seconds remaining before fault can be reset
input	2	MI Trip Reason	0x0001 = Restart Attempts Exceeded 0x0002 = Relay turned off (network/UI) 0x0004 = Contactor Failure 0x0008 = Under Current Trip 0x0010 = Overload Trip 0x0020 = GND Fault Trip 0x0040 = Current Unbalance Trip 0x0080 = Current Single Phase 0x0100 = Reserved (0) 0x0200 = High Power Trip 0x0400 = Over Voltage Trip 0x0800 = Under Voltage Trip 0x1000 = Voltage Unbalance Trip 0x2000 = Over Current Trip 0x4000 = Low Power Trip 0x8000 = Phase Reversal Trip
input	2	MI OL Status	0x0001 = Overload Tripped 0x0002 = GND Fault Tripped 0x0004 = High Power Tripped 0x0080 = Running
input	2	MI Error Code	0x0001 = Low Voltage Warning 0x0002 = High Voltage Warning 0x0004 = Voltage Unbalance Warning 0x0008 = Low Power Warning 0x0010 = Reverse Phase Warning 0x0020 = Current Unbalance Warning 0x0040 = Voltage Single Phase Warning 0x0080 = Current Single Phase Warning 0x0100 = GND Fault Warning
input	2	MI Aux Relay Trip Reason (120 V Control Power models only)	0x0001 = NA 0x0002 = Relay turned off (network/UI) 0x0004 = Contactor Failure 0x0008 = Under Current Trip 0x0010 = Overload Trip 0x0020 = GND Fault Trip 0x0040 = Current Unbalance Trip 0x0080 = Current Single Phase 0x0100 = Mains Freq Fault 0x0200 = High Power Trip 0x0400 = Over Voltage Trip 0x0800 = Under Voltage Trip 0x1000 = Voltage Unbalance Trip 0x2000 = Over Current Trip 0x4000 = Low Power Trip 0x8000 = Phase Reversal Trip

### C440 Overload Protection Relay

**Table 23. C440 Available IO Data for Cyclic Polling**

IO	Size (in bytes)	Tag	Description
N/A	0	C440 Overload Base	Base Module for the C440 Overload Relay. <b>Note:</b> Base module must be loaded into slot 1 of the configuration. This MUST be the first module listed in the configuration.
Output	1	Com Adapter Outputs	0x01 = Turn on Relay1 0x02 = Turn on Relay2
Input	1	Com Adapter Inputs	0x01 = I0 enabled 0x02 = I1 enabled 0x04 = I2 enabled 0x08 = I3 enabled
Input	1	Com Adapter Status	0x0001 = Adapter Connected 0x0002 = Message Error 0x0004 = Adapter Married
Output	2	C440 Command Register	0x0001 = Trip C440 0x0002 = Reset C440
Input	1	C440 Motor Control Status	0 = Stopped 1 = Running 2 = Tripped
Input	2	C440 Present Faults	Bit Feature 0 = Overload Fault 1 = Phase Imbalance 2 = Phase Loss Fault 3 = Ground Fault 4 = Network Trip Command 5 = NV Memory Failure 6 = Reserved
Input	2	C440 RMS Current I1	Scaling: value in 0.01 amps
Input	2	C440 RMS Current I2	Scaling: value in 0.01 amps
Input	2	C440 RMS Current I3	Scaling: value in 0.01 amps
Input	2	C440 RMS Current Ave	Scaling: value in 0.01 amps
Input	1	C440 FLA Current %	Presents the average current as a percent of the FLA setting
Input	1	C440 Used Thermal Pile %	Present thermal capacity (100% equates to a trip condition)
Input	2	C440 FLA Setting	The present FLA setting (the potentiometer selects this value)
Input	1	C440 Overload Trip class	The present FLA trip class
Input	1	C440 Phase Imbalance %	Percent of measured phase imbalance
Input	2	C440 GND Fault Current	Scaling: value in 0.01 amps
Input	1	C440 GND Fault %	Percent of ground fault measured: $GF\% = GFC / ([0.5] * FLA)$

**Table 23. C440 Available IO Data for Cyclic Polling, continued**

<b>IO</b>	<b>Size (in bytes)</b>	<b>Tag</b>	<b>Description</b>
Input	2	C440 Temperature	The temperature as seen by the microcontroller (accuracy ~10%)
Input	2	C440 Line Frequency	The line frequency measured by the device (the frequency is displayed in deciHz)
Input	2	C440 Feature Status	Bit Feature 01 = Class Index 00 = Class 10a 01 = Class 10 10 = Class 20 11 = Class 30 2 = Phase loss/imbalance enabled 3 = Ground fault enabled 4 = Auto reset enabled 5 = Remote reset active 8 = DIP switch position 0 9 = DIP switch position 1 10 = DIP switch position 2 11 = DIP switch position 3 12–15 = Reserved

## S611 Soft Starter

**Table 24. S611 Available IO Data for Cyclic Polling**

IO	Size (in bytes)	Configuration Modules	Notes
NA	0	S611 Soft Starter Base	Base module for S611 Soft Starter. <b>Note:</b> Base module must be loaded into slot 1 of the configuration. This MUST be the first module listed in the configuration.
output	1	Com Adapter Outputs	0x01 = Turn on Relay1 0x02 = Turn on Relay2
input	1	Com Adapter Inputs	0x01 = I0 enabled 0x02 = I1 enabled 0x04 = I2 enabled 0x08 = I3 enabled
input	1	Com Adapter Status	0x0001 = Adapter Connected 0x0002 = Message Error 0x0004 = Adapter Married 0x0008 = Adapter Marriage not complete
input	2	Motor Control Status	0x0001 = Run 0x0004 = In bypass 0x0020 = Faulted 0x0800 = Fault relay enabled 0x1000 = Aux relay enabled 0x2000 = Control from Net 0x4000 = Permissive enabled
input	2	Current I1	Scaling: value in 0.01 Amps
input	2	Current I2	Scaling: value in 0.01 Amps
input	2	Current I3	Scaling: value in 0.01 Amps
input	2	Current Average	Scaling: value in 0.01 Amps
input	2	Voltage L1-L2	Line voltage reading
input	2	Voltage L2-L3	Line voltage reading
input	2	Voltage L3-L1	Line voltage reading
input	2	Voltage Average	Average 3-phase voltage reading
input	2	Kilowatts Total	In 0.1kW
input	2	Power Factor Apparent	PF * 100
input	2	Power Sign	
input	2	Line frequency	Frequency in 0.01 Hz
input	2	Thermal Pile Percentage	Thermal pile % used
input	2	Current Unbalance Percent	% imbalance
input	2	Voltage Unbalance Percent	Percent of measured voltage imbalance
input	2	Residual Ground Current	Measured GND current in 0.1A
input	2	Pole Temperature T1	In 0.1 deg C
input	2	Pole Temperature T2	In 0.1 deg C
input	2	Pole Temperature T3	In 0.1 deg C
input	2	Pole Temperature Average	In 0.1 deg C
input	2	Number of Starts	Reset Though Command Register
input	2	Run Timer	Hours, Reset Though Command Register

**Table 24. S611 Available IO Data for Cyclic Polling, continued**

<b>IO</b>	<b>Size (in bytes)</b>	<b>Configuration Modules</b>	<b>Notes</b>
input	2	Trip Reason	Bit Fault 0 = Overload trip 1 = Jam fault 2 = Stall fault 3 = Current Imbalance fault 4 = Load disconnect fault 5 = PhaseLoss fault 6 = Mains voltage fault 7 = Phase reversal fault 8 = Shorted scr fault 9 = SCR not firing fault 10 = Pole over temp fault 11 = Bypass dropout fault 12 = SCR over current fault 13 = Contactor over current fault 14 = Communications fault 15 = Device fault
input	20	Active Fault Code	Last 10 fault codes
output	2	Motor Control	0x0001 Run 0x0004 Permissive 0x0008 reset
output	2	Command Register	1 = Clear Motor Run Hours, 2 = Clear Motor Start Count, 3 = Clear Fault Queue, 255 = Force Overload Rest (TP=0) <b>Note:</b> Command register will clear after write
output	2	Configuration Reset	1 = Soft Reset 2 = Factory Defaults

**S811+ Soft Starter**

**Table 25. S811+ Available IO Data for Cyclic Polling**

<b>IO</b>	<b>Size (in bytes)</b>	<b>Tag</b>	<b>Description</b>
N/A	0	S811 Soft Starter Base	Base Module for the CS811 Soft Starter. <b>Note:</b> Base module must be loaded into slot 1 of the configuration. This <b>MUST</b> be the first module listed in the configuration.
Output	1	Com Adapter Outputs	0x01 = Turn on Relay1 0x02 = Turn on Relay2
Input	1	Com Adapter Inputs	0x01 = I0 enabled 0x02 = I1 enabled 0x04 = I2 enabled 0x08 = I3 enabled
Input	1	COM Adapter Status	0x0001 = Adapter Connected 0x0002 = Message Error 0x0004 = Adapter Married
Input	1	MOTOR CONTROL STATUS	0 = Running1 1 = Running2 2 = Permissive 3 = Ramp2 4 = LocalControlStatus 5 = Faulted 6 = Warning 7 = In bypass
Input	6	Active Faults & Warning List	Latest 3 Fault/Warning codes
Input	2	Motor Control Faults	Bit Fault 0 = Phaseloss 1 = Phase Imbalance 2 = Thermal Pile 3 = Overcurrent 4 = Breaker Fault 5 = GND Fault 6 = Motor Stall 7 = Motor Jam 8 = OverTemp 9 = UnderLoad 10 = Reserved 11 = Estop 12 = Reserved 13 = Reserved 14 = Reserved 15 = Other
Input	2	Motor Control Warnings	Bit Warning 0 = Phaseloss 1 = Phase Imbalance 2 = Thermal Pile 3 = Overcurrent 4 = Breaker Fault 5 = GND Fault 6 = Motor Stall 7 = Motor Jam 8 = OverTemp 9 = UnderLoad 10 = Overload Impending Trip 11 = Reserved 12 = Reserved 13 = Reserved 14 = Reserved 15 = Other

**Table 25. S811+ Available IO Data for Cyclic Polling, continued**

<b>IO</b>	<b>Size (in bytes)</b>	<b>Tag</b>	<b>Description</b>
Input	2	Ave 3phase RMS AC Current as a %of FLA	0–255%; Percent of FLA setting
Input	2	Thermal Pile Percentage	0–255%; Thermal Pile % used (100% trip)
Input	6	Three-Phase RMS AC Voltage	L1, L2 & L3 RMS Voltages
Input	4	Total Number of Motor Starts	# of motor starts LSB1, LSB0 MSB, LSB2
Input	1	Analog Input Percent of Rated Range	0–255%; Analog input status reported as% of selected range
Input	1	Analog Input Value Status	Value Description 0x00 = Not Active 0x01 = Under Range 0x02 = Over Range 0x03 = Input Overdrive 0x04 = Input in range
Input	1	Discrete Data Input	Bit Description 0 = S811 TB Input#1 status 1 = S811 TB Input#2 status 2 = S811 TB input#3 status 3 = S811 TB Input#4 status 4 = C441 Input#1 status 5 = C441 Input#2 status 6 = C441 Input#3 status 7 = C441 Input#4 status
Input	1	Discrete Data Output	Bit Description 0 = S811 form1C relay 1 = S811 formA relay 2 = C441 Q1/Network output0 3 = C441 Q2/Network output1
Input	1	Network Outputs	Bit Description 0 = C441—Q1/Network output0 1= C441—Q2/Network output1
Input	20	Fault Queue	Last 10 Fault Codes
Input	4	Average RMS AC Current—Line	Average RMS Line Current (Float)
Input	4	Three-Phase RMS Current On the line	L1 RMS Line Current (Float)
Input	4	Three-Phase RMS Current On the line	L2 RMS Line Current (Float)
Input	4	Three-Phase RMS Current On the line	L3 RMS Line Current (Float)
Input	2	Scaled Average Three-Phase Currents in Amps—Line	Scaled Average current in Amps
Input	2	Scaled Three-Phase Currents in amps—Line	L1 RMS current in Amps
Input	2	Scaled Three-Phase Currents in amps—Line	L2 RMS current in Amps
Input	2	Scaled Three-Phase Currents in amps—Line	L3 RMS current in Amps
Input	2	Scaled Average Three-Phase Currents in deciamps—Line	Scaled Average current in 0.1 Amps
Input	2	Scaled Three-Phase Currents in deciamps—Line	L1 RMS current in 0.1 Amps
Input	2	Scaled Average Three-Phase Currents in deciamps—Line	L2 RMS current in 0.1 Amps



**Table 25. S811+ Available IO Data for Cyclic Polling, continued**

<b>IO</b>	<b>Size (in bytes)</b>	<b>Tag</b>	<b>Description</b>
Input	2	Scaled Three-Phase Currents in deciamps—Line	L3 RMS current in 0.1 Amps
Input	4	Average RMS AC Current—Pole	Average RMS Pole Current (Float)
Input	4	Three-Phase RMS Current on the Pole itself	L1 RMS Pole Current (Float)
Input	4	Three-Phase RMS Current on the Pole itself	L2 RMS Pole Current (Float)
Input	4	Three-Phase RMS Current on the Pole itself	L3 RMS Pole Current (Float)
Input	2	Scaled Average Three-Phase Currents in amps—Pole	Scaled Average pole current in Amps
Input	2	Scaled Three-Phase Currents in amps—Pole	L1 RMS pole current in Amps
Input	2	Scaled Three-Phase Currents in amps—Pole	L2 RMS pole current in Amps
Input	2	Scaled Three-Phase Currents in amps—Pole	L3 RMS pole current in Amps
Input	2	Scaled Average Three-Phase Currents in deciamps—Pole	Scaled Average pole current in 0.1 Amps
Input	2	Scaled Three-Phase Currents in deciamps—Pole	L1 RMS pole current in 0.1 Amps
Input	2	Scaled Three-Phase Currents in deciamps—Pole	L2 RMS pole current in 0.1 Amps
Input	2	Scaled Three-Phase Currents in deciamps—Pole	L3 RMS pole current in 0.1 Amps
Input	2	Power Factor	0 to 1.0000 (in 0.0001)
Input	2	Integer Average Three-Phase Real Power kW	Average Real Power (kW)
Input	6	Power Device Pole Temperature	L1 pole temp in 0.1 °C L2 pole temp in 0.1 °C L3 pole temp in 0.1 °C
Input	2	DC Control Voltage	DC voltage reported in 0.001 V
Input	2	Device Temperature in Degrees C	Device temp in 0.1 °C
Input	2	Auto Reset Count	# of times S811+ has been auto reset
Input	2	Line Frequency	Line Frequency (in 0.01 Hz)
Input	1	Line Phase Sequence	0x01 = ABC Phase sequence 0x02 = ACB Phase sequence
Input	20	Fault List	Last 10 Fault/Warning Codes
Input	2	Application Status	Applications status (present fault)
Input	1	Motor Inputs Level Sense Enabled	0x00 = edge sense 0x01 = level sense
Input	4	Firmware Version List	
Input	2	Hardware Version List	

**Table 25. S811+ Available IO Data for Cyclic Polling, continued**

<b>IO</b>	<b>Size (in bytes)</b>	<b>Tag</b>	<b>Description</b>
Output	1	Modbus Device Reset Register	0 = No Reset 1 = Soft Reset 2 = Factory Reset 3 = App parameter Reset 4 = reserved 5 = reserved 6 = Flush Fault History/Queue 7 = Reset Motor Starts
Input	1	S811 Device Product Code	
Output	1	Motor Control	Bit Description 0 = Run1 1 = Run2 2 = reserved 3 = Fault Reset 4 = reserved 5 = reserved 6 = reserved 7 = Ramp2 enable

## PROFIBUS Diagnostic Telegrams

### C441 Motor Insight Overload Protection Relay

**Table 26. C441 Diagnostic Telegram**

Byte	Bit	Description	Ext Diag Bit
1	0	Diag.station: Station does not exist (set by Master)	
	1	Diag.station_not_ready: Station is not ready for data exchange	
	2	Diag.cfg_fault: Configuration data does not agree	
	3	Diag.ext: Slave has extended diagnostic data	
	4	Diag.not_supported: Requested function is not supported	
	5	Diag.invalid_slave_response: Sets slave to 0, fixed	
	6	Dig.prm_fault: Incorrect parameterization	
2	7	Diag.master_lock: Slave is parameterized by different master	
	0	Diag.prm_req: Slave has to be re-parameterized	
	1	Diag.stat_diag: Static diagnosis	
	2	Fixed at 1	
	3	Diag.WD_on: Threshold monitoring activated	
	4	Diag.freeze_mode: Freeze command received	
	5	Diag.sync_mode: Sync command received	
	6	Reserved	
3	7	Diad.deactivated (sets master)	
	0–6	Reserved	
4	7	Diag.ext_overflow	
		Master address after parameterization (FF before parameterization)	
5		Ident Number (MSB)	
6		Ident Number (LSB)	
7		Header byte—Device Data	
	0	Length of User Ext Diagnostic Data	
	1		
	2		
	3		
	4		
	5		
	6	0 = Device Data	
7	0 = Device Data		
8	0	1 = Adapter Connected; 0 = Adapter Not Connected	F/S
	1	Reserved	
	2	1 = Adapter Married	S/S
	3	Reserved	
	4	Reserved	
	5	Reserved	
	6	Reserved	
	7	Reserved	

**Table 26. C441 Diagnostic Telegram, continued**

Byte	Bit	Description	Ext Diag Bit
9	8	1 = Overload Trip	F/S
	9	1 = GND Fault Trip	F/S
	10	1 = High Power Trip	F/S
	11	Reserved	
	12	Reserved	
	13	Reserved	
	14	Reserved	
	15	1 = Relay Running	S/S
10	16	Reserved	
	17	Reserved	
	18	Reserved	
	19	Reserved	
	20	Reserved	
	21	Reserved	
	22	Reserved	
	23	Reserved	
11	24	1 = Restart Attempts Exceeded Fault	F/S
	25	1 = Relay Off Command (Network/UI)	
	26	1 = Contactor Failure	F/S
	27	1 = Under Current Fault	F/S
	28	1 = Overload Fault	F/S
	29	1 = GND Fault	F/S
	30	1 = Current Unbalance Fault	F/S
	31	1 = Current Single-Phase Fault	F/S
12	32	Reserved	
	33	1 = High Power Fault	F/S
	34	1 = Over Voltage Fault	F/S
	35	1 = Under Voltage Fault	F/S
	36	1 = Voltage Unbalance Fault	F/S
	37	1 = Over Current Fault	F/S
	38	1 = Low Power Fault	F/S
	39	1 = Phase Reversal Fault	F/S
13	40–47	Reserved	F/S
14	48–55	Reserved	F/S

### C440 Overload Protection Relay

**Table 27. C440 Diagnostic Telegram**

Byte	Bit	Description	Ext Diag Bit	
1	0	Diag.station: Station does not exist (set by Master)	Default Diagnostic Data	
	1	Diag.station_not_ready: Station is not ready for data exchange		
	2	Diag.cfg_fault: Configuration data does not agree		
	3	ext.Diag: Slave has high priority extended diagnostic data		
	4	Diag.not_supported: Requested function is not supported		
	5	Diag.invalid_slave_response: Sets slave to 0, fixed		
	6	Dig.prm_fault: incorrect parameterization		
2	7	Diag.master_lock: Slave is parameterized by different master	Default Diagnostic Data	
	0	Diag.prm_req: Slave has to be re-parameterized		
	1	Diag.stat_diag: Static diagnosis		
	2	Fixed at 1		
	3	Diag.WD_on: Threshold monitoring activated		
	4	Diag.freeze_mode: Freeze command received		
	5	Diag.sync_mode: Sync command received		
3	6	Reserved	Default Diagnostic Data	
	7	Diag.ext_overflow		
4	—	Master address after parameterization (FF before parameterization)	Default Diagnostic Data	
5	—	Ident number (MSB)	Default Diagnostic Data	
6	—	Ident number (LSB)	Default Diagnostic Data	
7	—	Header byte – Device Data	Extended Diagnostic Data	
	0	Length of User Ext Diagnostic Data		
	1	Length of User Ext Diagnostic Data		
	2	Length of User Ext Diagnostic Data		
	3	Length of User Ext Diagnostic Data		
	4	Length of User Ext Diagnostic Data		
	5	Length of User Ext Diagnostic Data		
	6	0 = Device Data		
	7	0 = Device Data		
8	0	1 = Adapter Connected; 0 = Adapter Not Connected	F/S	Extended Diagnostic Data
	1	Reserved		
	2	1 = Adapter Married	S/S	
	3	Reserved		
	4	Reserved		
	5	Reserved		
	6	Reserved		
9	8–15	Reserved		Extended Diagnostic Data
10	16–23	Reserved		Extended Diagnostic Data

**Table 27. C440 Diagnostic Telegram, continued**

Byte	Bit	Description		Ext Diag Bit
11	24–31	Reserved		Extended Diagnostic Data
12	32–39	Reserved		Extended Diagnostic Data
13	40–47	Reserved		Extended Diagnostic Data
14	48–55	Reserved		Extended Diagnostic Data
15	56	1 = C440 Overload Running	S/S	Extended Diagnostic Data
	57–63	Reserved		
16	64	1 = C440 Overload Trip	F/S	Extended Diagnostic Data
	65	1 = C440 Phase Imbalance Trip	F/S	
	66	1 = C440 Phase Loss Trip	F/S	
	67	1 = C440 GND Current Trip	F/S	
	68	1 = C440 Network Trip	F/S	
	69	1 = C440 NVRAM Memory Fault	F/S	
	70–71	Reserved		
17	72–79	Reserved		Extended Diagnostic Data
18	80–87	Reserved		Extended Diagnostic Data
19	88–95	Reserved		Extended Diagnostic Data
20	96–103	Reserved		Extended Diagnostic Data
21	104–111	Reserved		Extended Diagnostic Data
22	112–119	Reserved		Extended Diagnostic Data
23	120–127	Reserved		Extended Diagnostic Data
24	128–135	Reserved		Extended Diagnostic Data
25	136–143	Reserved		Extended Diagnostic Data
26	144–151	Reserved		Extended Diagnostic Data

**Table 28. Ext Diag Bit Key**

Code	Bit Sets/Clears
F/S	Ext diag bit set/ext diag bit clears
S/S	Ext diag bit clear/ext diag bit clear

**S611 Soft Starter**

**Table 29. S611 Diagnostic Telegram**

Byte	Bit	Description	Ext Diag Bit	Notes
1	0	Diag.station: Station does not exist (set by Master)		Default Diagnostic Data
	1	Diag.station_not_ready: Station is not ready for data exchange		
	2	Diag.cfg_fault: Configuration data does not agree		
	3	ext.Diag: Slave has high priority extended diagnostic data		
	4	Diag.not_supported: Requested function is not supported		
	5	Diag.invalid_slave_response: Sets slave to 0, fixed		
	6	Dig.prm_fault: incorrect parameterization		
2	7	Diag.master_lock: Slave is parameterized by different master		
	0	Diag.prm_req: Slave has to be re-parameterized		
	1	Diag.stat_diag: Static diagnosis		
	2	Fixed at 1		
	3	Diag.WD_on: Threshold monitoring activated		
	4	Diag.freeze_mode: Freeze command received		
	5	Diag.sync_mode: Sync command received		
3	6	Reserved		
	7	Diad.deactivateed (sets master)		
4	Master address after parameterization (FF before parameterization)			
5	Ident Number (MSB)			
6	Ident Number (LSB)			
7	Header byte —Device Data			Extended Diagnostic Data
	0	Length of User Ext Diagnostic Data		
	1			
	2			
	3			
	4			
	5			
	6	0 = Device Data		
7	0 = Device Data			
8	0	1 = Adapter Connected; 0 = Adapter Not Connected	F/S	
	1	Reserved		
	2	1 = Adapter Married	S/S	
	3	Reserved		
	4	Reserved		
	5	Reserved		
	6	Reserved		
9	8–15	Reserved		
10	16–23	Reserved		

**Table 29. S611 Diagnostic Telegram, continued**

Byte	Bit	Description	Ext Diag Bit	Notes
11	24–31	Reserved		Extended Diagnostic Data
12	32–39	Reserved		
13	40–47	Reserved		
14	48–55	Reserved		
15	56–63	Reserved		
16	64–71	Reserved		
17	72–79	Reserved		
18	80	1 = S611 Run	S/S	
	81	Reserved		
	82	1 = S611 In bypass	S/S	
	83	Reserved		
	84	Reserved		
	85	1 = S611 Faulted; 0 = S611 not faulted	F/S	
	86–87	Reserved		
19	88–92	Reserved		
	93	1 = Control from Net; 0 = local control	S/S	
	94	1 = Permissive enabled; 0 = Permissive disabled	S/S	
	95	Reserved		
20	96	Reserved		
	97	1 = Overload trip	F/S	
	98	1 –Jam trip	F/S	
	99	1 = Stall trip	F/S	
	100	1 = Current Imbalance trip	F/S	
	101	1 = Load disconnect trip	F/S	
	102	1 = Phase Loss trip	F/S	
	103	1 = Mains voltage fault trip	F/S	
21	104	1 = Phase reversal trip	F/S	
	105	1 = Shorted scr trip	F/S	
	106	1 = SCR not firing trip	F/S	
	107	1 = Pole over temp trip	F/S	
	108	1 = Bypass failure trip	F/S	
	109	1 = SCR over current trip	F/S	
	110	1 = Contactor over current trip	F/S	
	111	1 = Device fault trip	F/S	



**S811+ Soft Starter**

**Table 30. S811+ Soft Starter Diagnostic Telegram**

Byte	Bit	Description	Ext Diag Bit
1	0	Diag.station: Station does not exist (set by Master)	
	1	Diag.station_not_ready: Station is not ready for data exchange	
	2	Diag.cfg_fault: Configuration data does not agree	
	3	Diag.ext: Slave has extended diagnostic data	
	4	Diag.not_supported: Requested function is not supported	
	5	Diag.invalid_slave_response: Sets slave to 0, fixed	
	6	Dig.prm_fault: Incorrect parameterization	
2	7	Diag.master_lock: Slave is parameterized by different master	
	0	Diag.prm_req: Slave has to be re-parameterized	
	1	Diag.stat_diag: Static diagnosis	
	2	Fixed at 1	
	3	Diag.WD_on: Threshold monitoring activated	
	4	Diag.freeze_mode: Freeze command received	
	5	Diag.sync_mode: Sync command received	
	6	Reserved	
3	7	Diad.deactivated (sets master)	
	0–6	Reserved	
4		Diag.ext_overflow	
4		Master address after parameterization (FF before parameterization)	
5		Ident Number (MSB)	
6		Ident Number (LSB)	
7		Header byte—Device Data	
	0	Length of User Ext Diagnostic Data	
	1		
	2		
	3		
	4		
	5		
	6	0 = Device Data	
7	0 = Device Data		
8	0	1 = Adapter Connected; 0 = Adapter Not Connected	F/S
	1	Reserved	
	2	1 = Adapter Married	S/S
	3	Reserved	
	4	Reserved	
	5	Reserved	
	6	Reserved	
	7	Reserved	
9	8–15	Reserved	
10	16–23		

**Table 30. S811+ Soft Starter Diagnostic Telegram, continued**

Byte	Bit	Description	Ext Diag Bit
11	24–31		
12	32–39		
13	40–47		
14	48–55		
15	56–63		
16	64–71		
17	72–79		
18	80–87		
19	88–95		
20	96–103		
21	104–111		
22	0	Running1	S/S
	1	Running2	S/S
	2	Permissive	S/S
	3	Ramp2	S/S
	4	LocalControlStatus	S/S
	5	Faulted	F/S
	6	Warning	S/S
	7	In bypass	S/S
23	0	Phaseloss	F/S
	1	Phase Imbalance	F/S
	2	Thermal Pile	F/S
	3	Overcurrent	F/S
	4	Breaker Fault	F/S
	5	GND Fault	F/S
	6	Motor Stall	F/S
	7	Motor Jam	F/S
	8	OverTemp	F/S
	9	UnderLoad	F/S
	10	Reserved	
	11	Estop	F/S
	12	Reserved	
	13	Reserved	
	14	Reserved	
15	Other	F/S	

**Table 30. S811+ Soft Starter Diagnostic Telegram, continued**

Byte	Bit	Description	Ext Diag Bit
24	0	0 Phaseloss	S/S
	1	Phase Imbalance	S/S
	2	Thermal Pile	S/S
	3	Overcurrent	S/S
	4	Breaker Fault	S/S
	5	GND Fault	S/S
	6	Motor Stall	S/S
	7	Motor Jam	S/S
	8	OverTemp	S/S
	9	UnderLoad	S/S
	10	Overload Impending Trip	S/S
	11	Reserved	
	12	Reserved	
	13	Reserved	
	14	Reserved	
	15	Other	S/S

**Table 31. Ext Diag Bit Key**

Code	Bit Sets/Clears
F/S	Ext diag bit sets / Ext diag bit clears
S/S	Ext diag bit clear / Ext diag bit clear

## Application Example: Operating a C441 Motor Insight with a Siemens PLC on PROFIBUS-DP

### Introduction

The purpose of this application note is to demonstrate how to operate and monitor a C441 Motor Insight Overload Protection Relay via a PROFIBUS DP network and a Siemens Simatic PLC with a PROFIBUS master module. The C441Q or the C441S PROFIBUS modules are used to interface the Motor Insight to the PROFIBUS network. The only difference between the two modules is that the C441Q has 24 Vdc inputs and the C441S has 120 Vac inputs.

A GSD file is available for the Motor Insight and it may be downloaded from the Eaton website. The PROFIBUS address is configured using the DIP switches on the C441Q/S modules.

While this application example uses a Siemens Simatic S7-1200 controller with a PROFIBUS DP master module to control and monitor the Motor Insight, any PROFIBUS master may be used for this purpose. Siemens Simatic Step 7 Basic, V13 programming software was used for this application example. The Simatic S7 PLC will be configured to poll the Motor Insight to operate and monitor the overload protection relay.

The C441Q/S modules support PROFIBUS DPV0. This document will demonstrate how to configure the PROFIBUS master to monitor some of the many available parameters from the Motor Insight as well as controlling the outputs on the C441Q/S modules.

### System Overview

Because the C441 Motor Insight is an Overload Protection Relay and not a Motor Starter, an output on the C441Q/S PROFIBUS interface module is used to control energizing and de-energizing an Eaton **XT** or Freedom contactor. This normally open relay output contact is wired in series with the normally closed 95/96 Fault contact on the Motor Insight. The Siemens PLC controls the motor over PROFIBUS via the relay output on the C441Q/S module and the Motor Insight protects the motor with its fault contact.

### Creating a Project in Siemens Simatic Software

Create a project in Simatic software by starting the software and selecting Create New Project.

Enter a Project name and Path where the project will be stored, and then select the Create button per the following:

Create new project	
Project name:	C441_MI
Path:	C:\Users\E0057779\Documents\Motor Insight\Profibus GSD Files Rev2
Author:	E0057779
Comment:	

## Application Example: Operating a C441 Motor Insight with a Siemens PLC on PROFIBUS-DP

From the next screen, select Configure a device, then select Add new device. An S7-1200 PLC is being used for this application. Select the CPU under Unspecified CPU 1200. Choose the correct version (V3.0 for this example) and select the ADD button. The following Project View will be displayed, showing a generic CPU.

The screenshot displays the Siemens TIA Portal interface. On the left is the 'Project tree' showing the hierarchy: C441\_MI > PLC\_1 [Unspecified CPU 1200]. The main workspace shows a rack configuration for 'PLC\_1' with a 'Siemens S7-1200' CPU module in slot 1. A yellow warning box at the bottom right states: 'The device is not specified. → Please use the [Hardware catalog](#) to specify the CPU, → or [detect](#) the configuration of the connected device.'

## Application Example: Operating a C441 Motor Insight with a Siemens PLC on PROFIBUS-DP

Click the CPU box to select it, then select “detect” in the yellow area below it. The Hardware Detection screen will be displayed as follows:

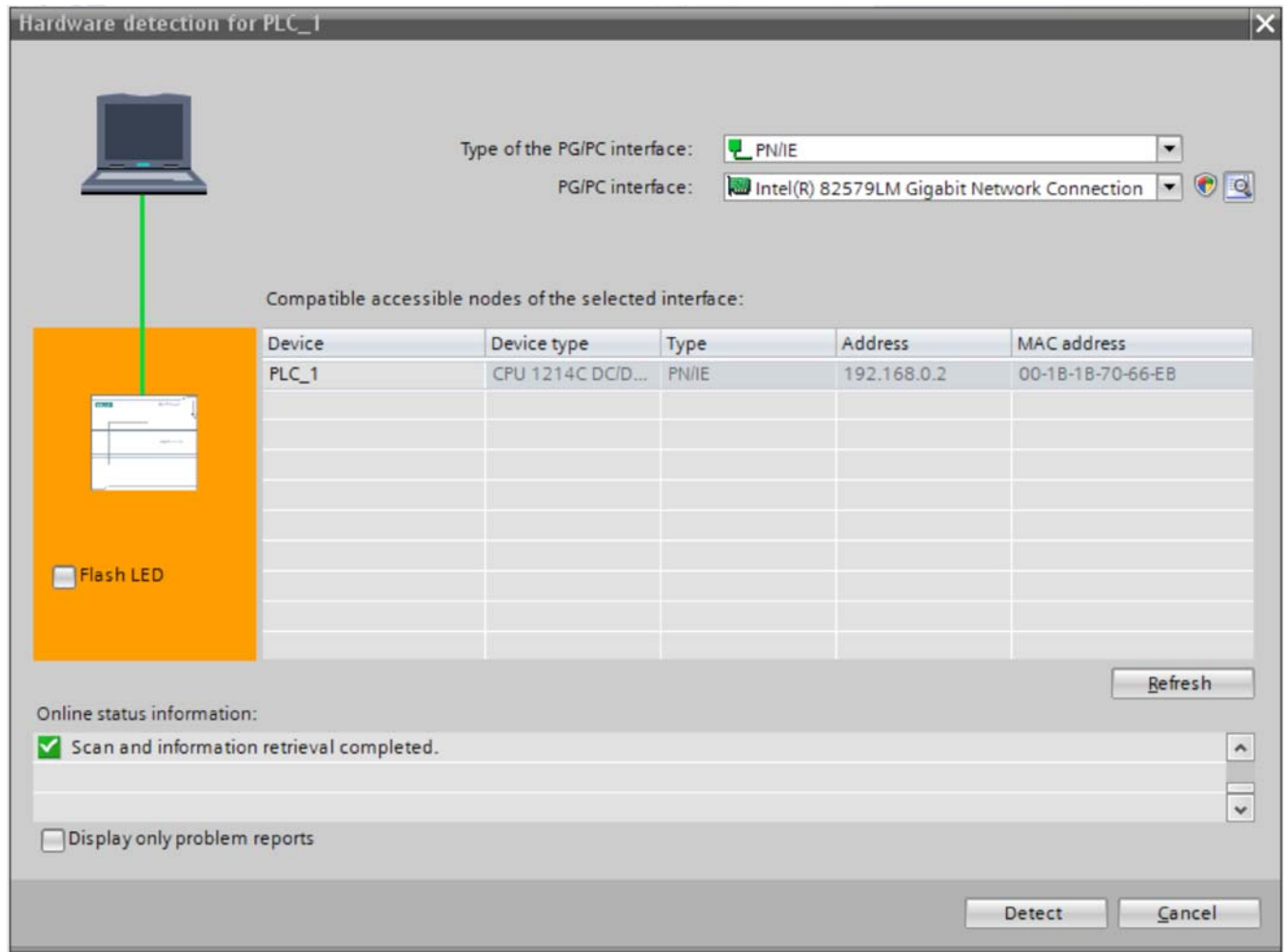

## Application Example: Operating a C441 Motor Insight with a Siemens PLC on PROFIBUS-DP

For this example, the Ethernet port on the PLC is being used to communicate with the PLC. It will also be used to upload/download the project later. Set up your computer and software to communicate with your PLC. Once communications is properly set up, select the Detect button and the software will detect the actual controller type and the PROFIBUS master module connected to it as follows:

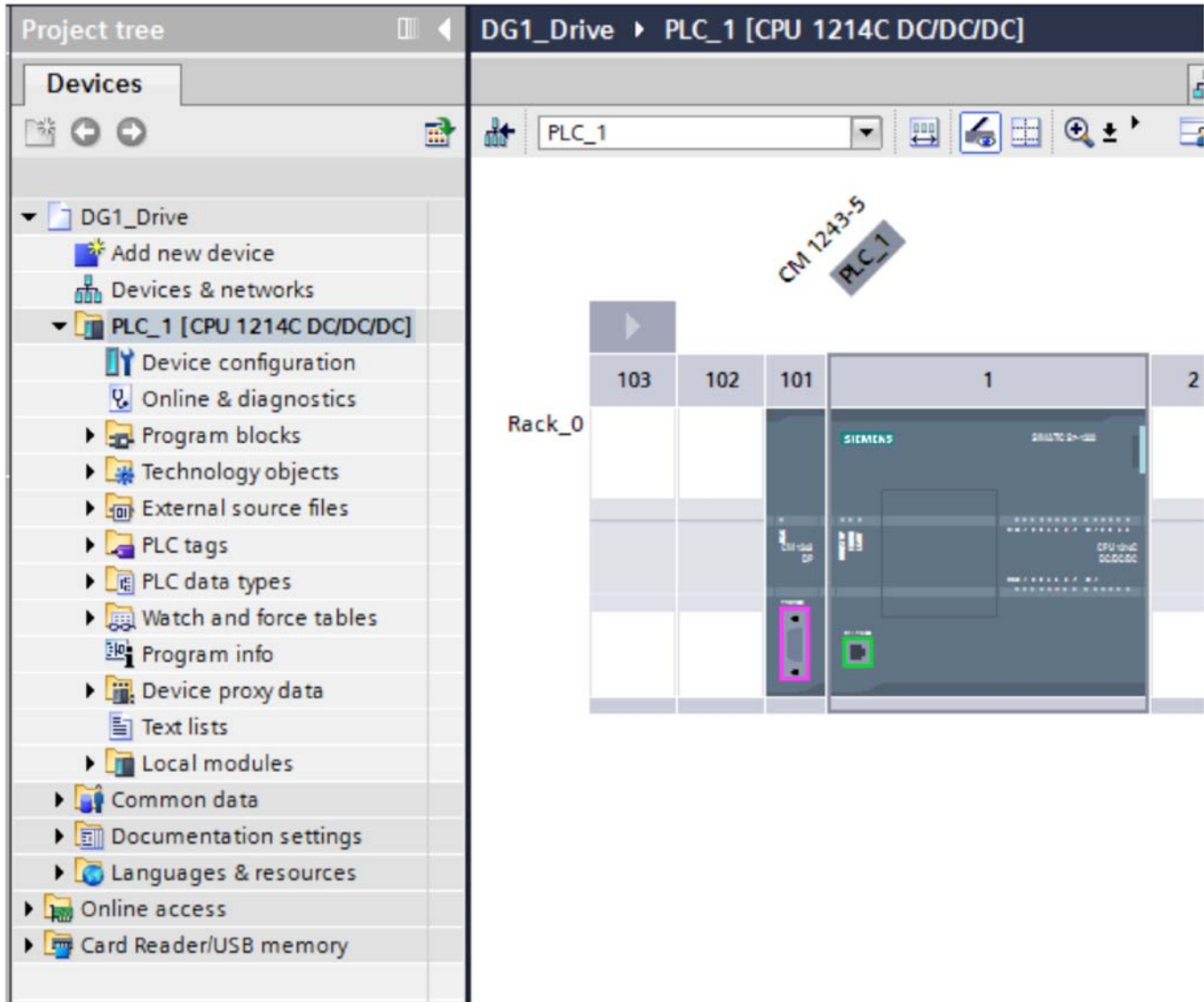

Connect a standard PROFIBUS cable between the PROFIBUS master and the C441Q/S module. Use the standard PROFIBUS connectors and turn on the termination on one or both ends. Refer to the C441 Motor Insight User Manual (publication MN04209001E) for details on the PROFIBUS cable connector pinouts if needed.

## Application Example: Operating a C441 Motor Insight with a Siemens PLC on PROFIBUS-DP

Then in the Simatic software, select the Options drop down menu and choose: "Install general station description file (gsd)". Download the GSD file from the Eaton website for the C441Q/S modules, then search for it on your hard drive by selecting the ellipses in the upper right hand corner of the following screen:

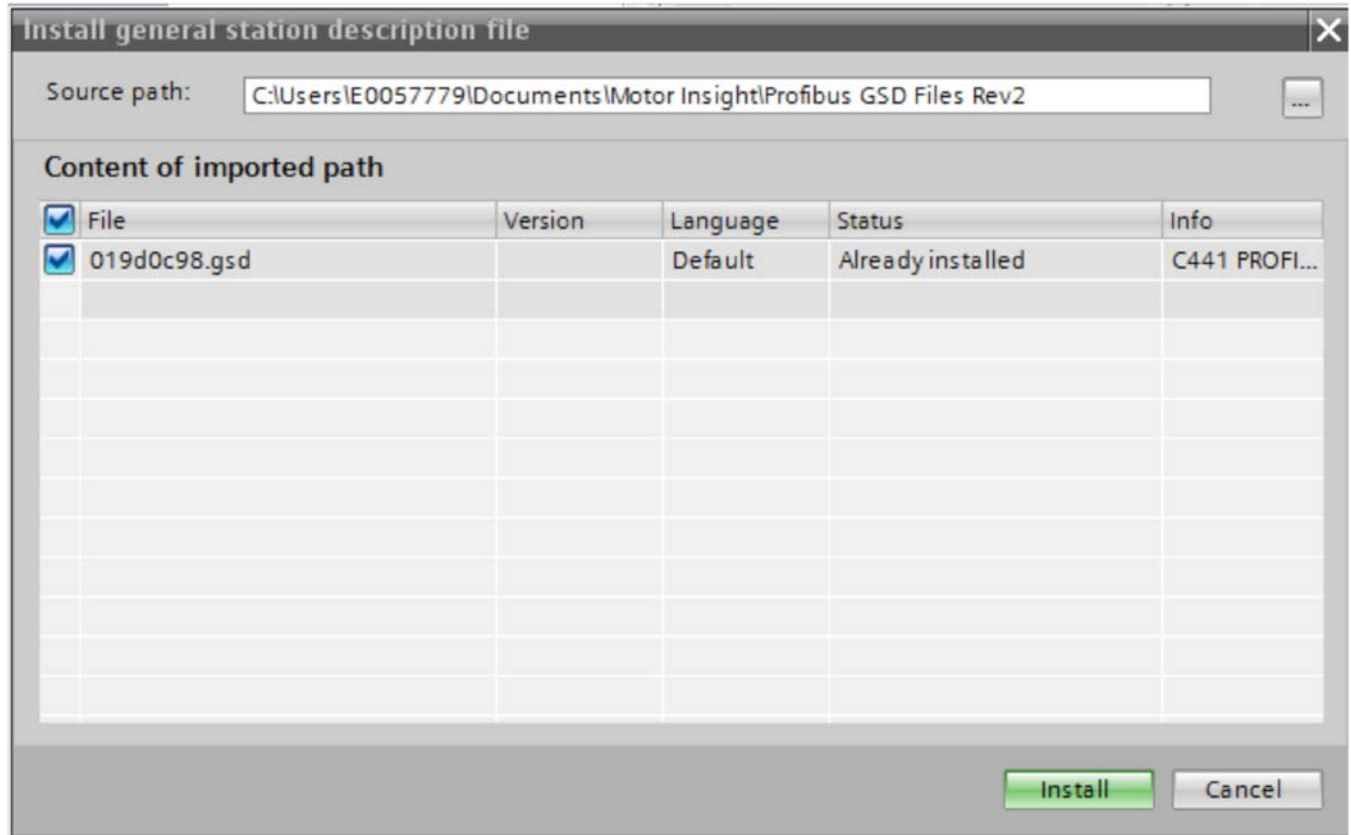

Select the 2 boxes by selecting the box next to File, then select Install and follow the directions to install the GSD file for the C441 Motor Insight.



## Application Example: Operating a C441 Motor Insight with a Siemens PLC on PROFIBUS-DP

Per the following, select the Network View tab.

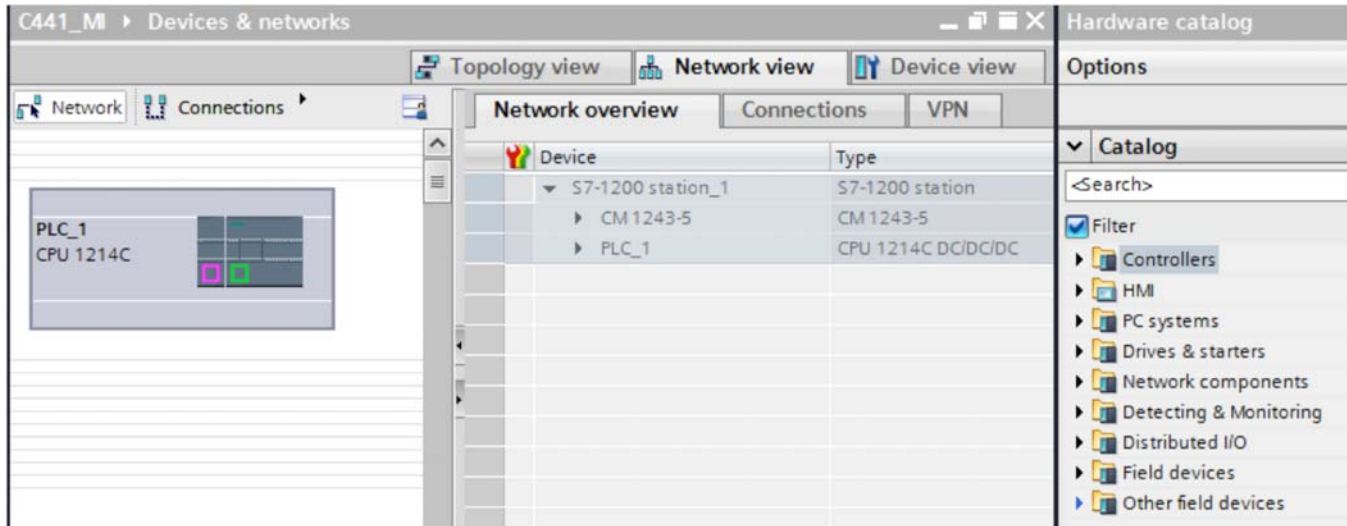

The PLC will be displayed. In the Catalog at the far right, select the arrow next to "Other field devices", then next to PROFIBUS DP / I/O / Eaton Corp / C441 PROFIBUS Adapter / C441 PROFIBUS ADAPTER / C441 PROFIBUS ADAPTER. Drag and drop the device called C441 PROFIBUS ADAPTER below the category C441 PROFIBUS ADAPTER and drop it below the controller/PROFIBUS master on the Network View screen. Then select the purple square on the controller/PROFIBUS master and drag it to the purple square on the PROFIBUS Option Board and release the mouse button.

# Application Example: Operating a C441 Motor Insight with a Siemens PLC on PROFIBUS-DP

The following should now be displayed:

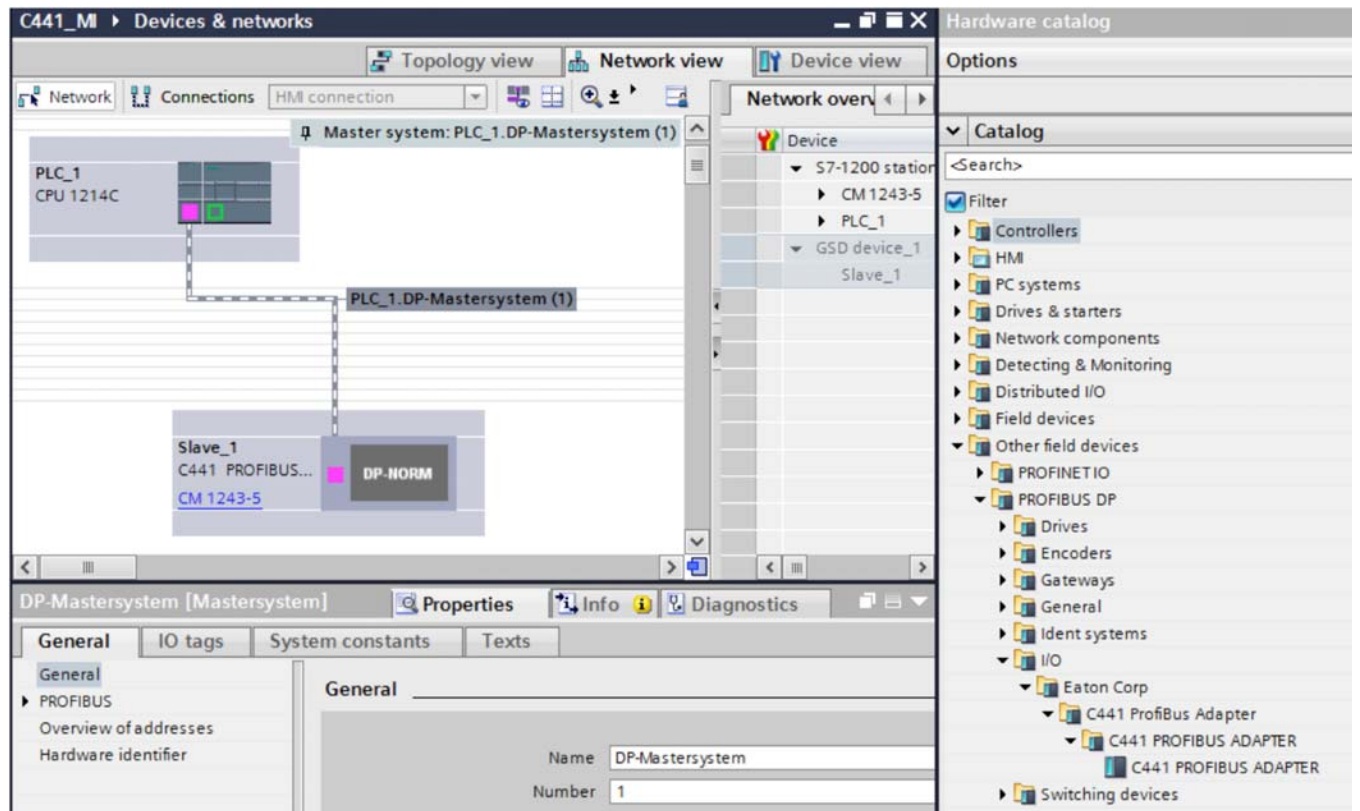

## Application Example: Operating a C441 Motor Insight with a Siemens PLC on PROFIBUS-DP

The PROFIBUS network has been created in the offline project. Double click the Slave\_1 C441 PROFIBUS module and the following will be displayed:

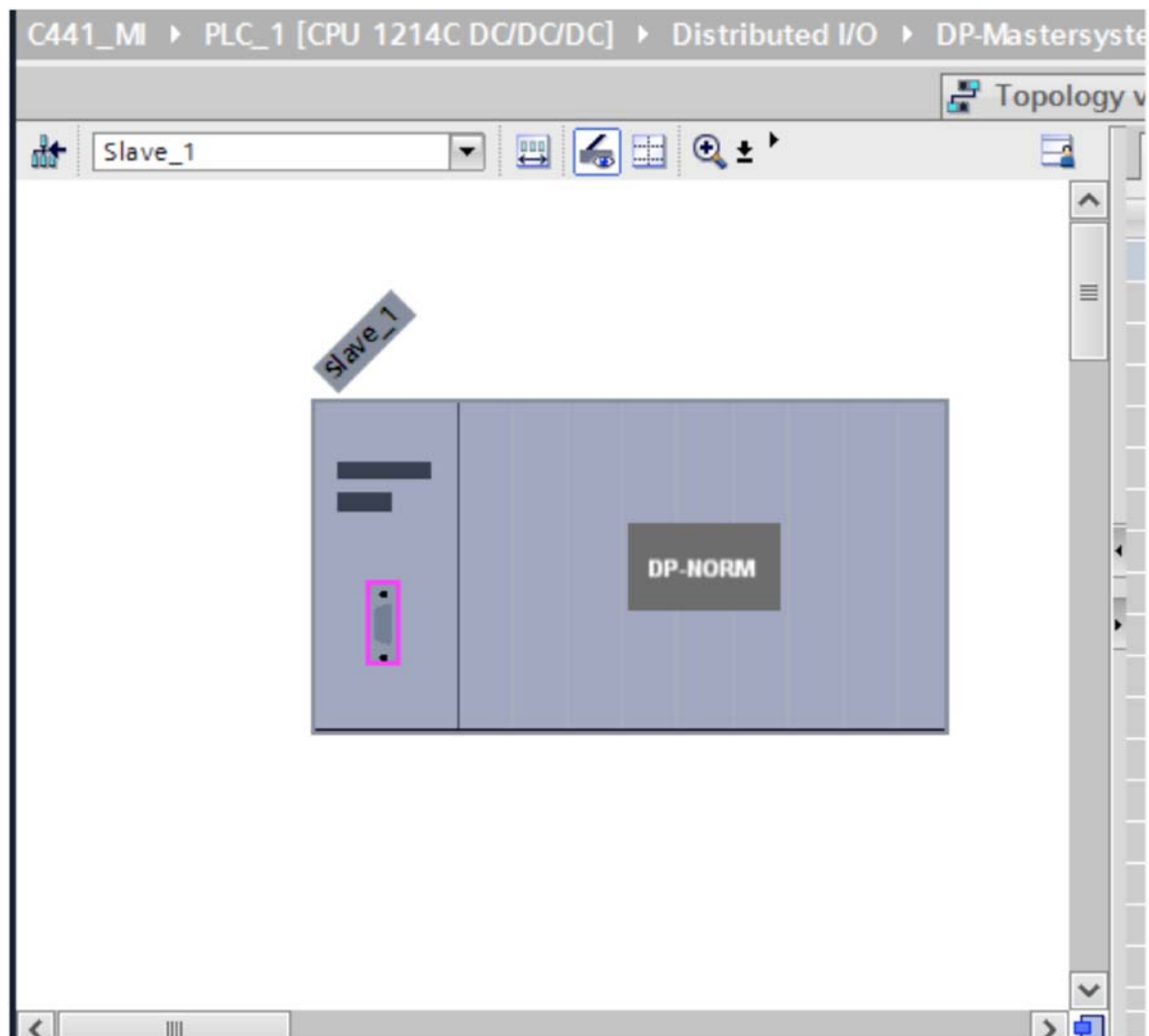

## Application Example: Operating a C441 Motor Insight with a Siemens PLC on PROFIBUS-DP

Double click the Slave\_1 box and its Properties will open below it as follows:

The screenshot shows the Siemens SIMATIC Manager interface. The top window, titled 'C441\_MI > PLC\_1 [CPU 1214C DC/DC/DC] > Distributed I/O > DP-Mastersystem (1): PROFIBUS\_1 > Slave\_1', displays a rack configuration. A 'Slave\_1' module is highlighted in the rack. The 'Device overview' table on the right lists the modules in the rack:

Module	Rack
Slave_1	0
IO StandAlone Base_1	0
Com Adapter Outputs_1	0
Com Adapter Inputs_1	0
Empty Module_1	0
Empty Module_2	0
Empty Module_3	0
Empty Module_4	0
Empty Module_5	0
Empty Module_6	0
Empty Module_7	0
Empty Module_8	0
Empty Module_9	0
Empty Module_10	0
Empty Module_11	0
Empty Module_12	0
Empty Module_13	0
Empty Module_14	0
Empty Module_15	0

The bottom window, titled 'Slave\_1 [Module]', shows the 'Properties' dialog for the selected module. The 'General' tab is active, and the 'General' section is expanded. The fields are as follows:

- Name: Slave\_1
- Author: E0057779
- Comment: (empty text area)
- Rack: 0
- Slot: 0

Change the PROFIBUS address to match the address selected with the DIP switches on the C441Q/S module. For this example, the PROFIBUS address being used is 3. The Transmission speed will default to 1.5 Mbps, which is fine. Any speed will work here because the C441Q/S module is set to Auto. The data rate is dependent on the overall network cable length.

The C441Q/S modules are used to interface multiple devices to PROFIBUS as well be a discrete I/O block on the network. The default base is "IO StandAlone Base". To use this module with a C441 Motor Insight, select the row with IO StandAlone Base\_1 under the Device Overview tab and press the delete key, then confirm you want to delete it.

## Application Example: Operating a C441 Motor Insight with a Siemens PLC on PROFIBUS-DP

Drag and drop the C441 Motor Insight Base from the Catalog onto the empty row. It should look like the following:

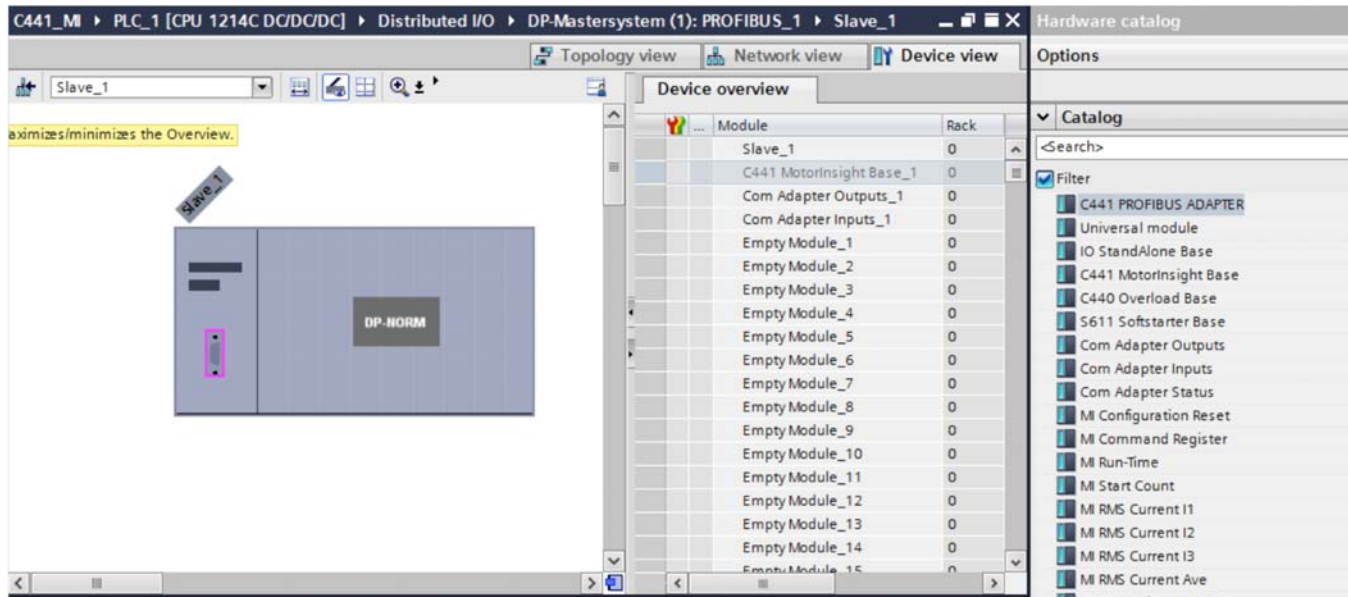

The two rows following the C441 Motor Insight Base are for controlling the outputs and monitoring the inputs on the C441Q/S module. These will not be deleted, but used in this application example.

The Empty Module rows can be deleted and parameters to be monitored may be dragged and dropped in their place as needed. For this example, the following parameters will be added, as shown below:

Module	Rack	Slot	I address	Q address	Type	Order no.	Fir
Slave_1	0	0			C441 PROFIBUS AD...		V2
C441 MotorInsight Base_1	0	Base ...			C441 MotorInsight ...		
Com Adapter Outputs_1	0	Data E...		2	Com Adapter Outp...		
Com Adapter Inputs_1	0	Data E...	2		Com Adapter Inputs		
MI RMS Current Ave_1	0	Data E...	68...69		MI RMS Current Ave		
MI RMS Voltage Average_1	0	Data E...	70...71		MI RMS Voltage Av...		
MI Total Kilowatts_1	0	Data E...	72...73		MI Total Kilowatts		
MI Voltage Unbalance %_1	0	Data E...	74...75		MI Voltage Unbalan...		
MI Current Unbalance %_1	0	Data E...	76...77		MI Current Unbalan...		
MI Error Code_1	0	Data E...	78...79		MI Error Code		
Empty Module_7	0	Data E...			Empty Module		
Empty Module_8	0	Data E...			Empty Module		
Empty Module_9	0	Data E...			Empty Module		
Empty Module_10	0	Data E...			Empty Module		
Empty Module_11	0	Data E...			Empty Module		
Empty Module_12	0	Data E...			Empty Module		
Empty Module_13	0	Data E...			Empty Module		
Empty Module_14	0	Data E...			Empty Module		
Empty Module_15	0	Data E...			Empty Module		

Note the I/O addresses assigned to the parameters. These will be added to the PLC Tags area and tag names will be added for these addresses. The tag names can then be used in the PLC program to control and monitor the Motor Insight and the C441Q/S module's I/O.

## Setting up the Configuration File in the Simatic Software

To access the configuration parameters for the C441 Motor Insight, select the C441 Motor Insight Base under the Device Overview, and then select “Device-Specific Parameters” in the Properties, as shown below:

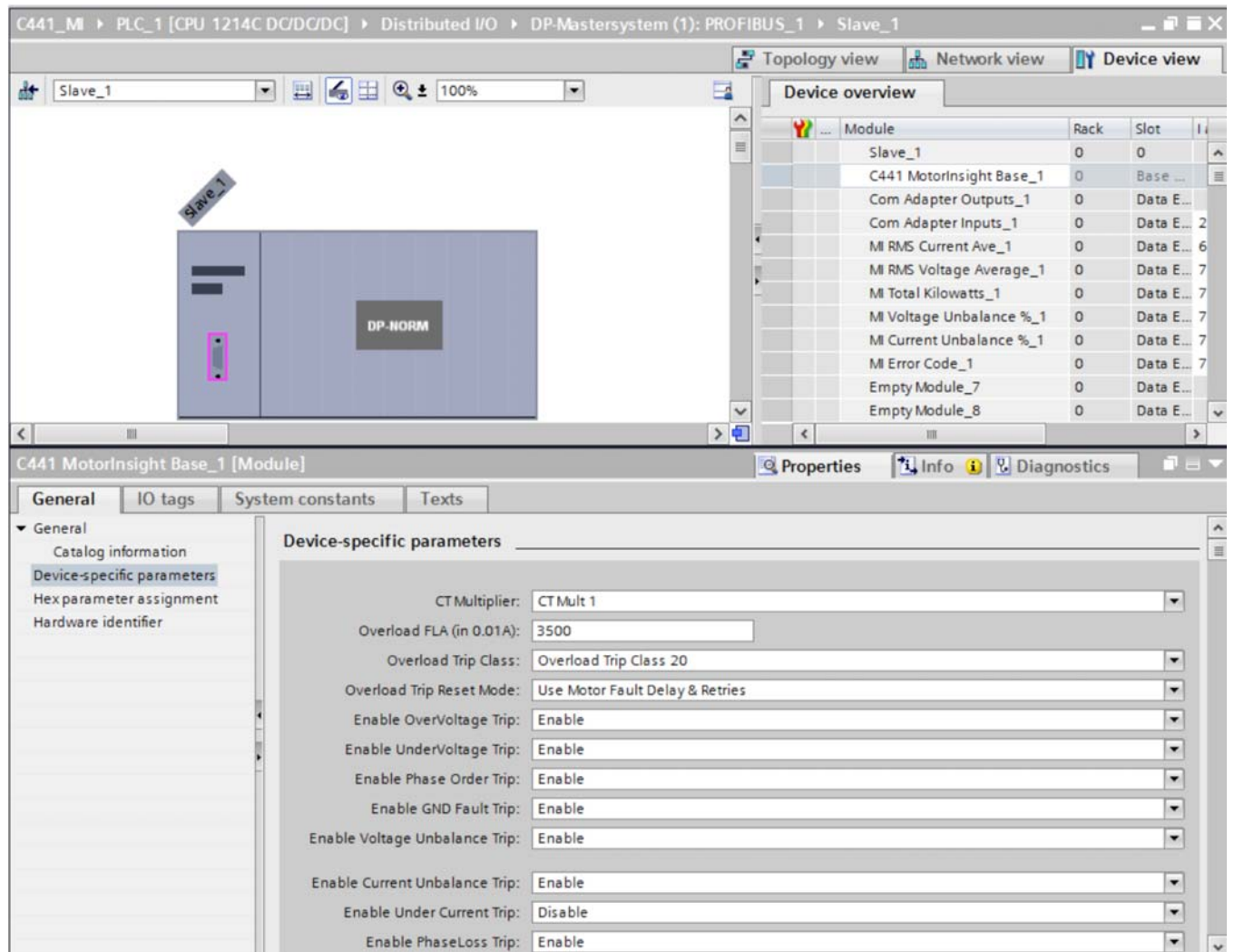

Each C441 Motor Insight in the application can be configured using the Device-Specific Parameters for each device. This file is downloaded to each C441 device each time the PROFIBUS master makes a connection with the slave module. This feature allows for minimal downtime should a slave device need replacing and provides an easy way to configure each C441 device on the network during the initial startup. These Device-Specific Parameters are a complete list of all configuration parameters for the C441 Motor Insight.

### Assigning Tag Names to C441 Motor Insight I/O Addresses

The I/O addresses for the parameters selected for the C441 Motor Insight are shown below for this example:

Module	Rack	Slot	I address	Q address	Type
Slave_1	0	0			C441 PROFIBUS AD...
C441 MotorInsight Base_1	0	Base ...			C441 MotorInsight ...
Com Adapter Outputs_1	0	Data E...		2	Com Adapter Outp...
Com Adapter Inputs_1	0	Data E...	2		Com Adapter Inputs
MI RMS Current Ave_1	0	Data E...	68...69		MI RMS Current Ave
MI RMS Voltage Average_1	0	Data E...	70...71		MI RMS Voltage Av...
MI Total Kilowatts_1	0	Data E...	72...73		MI Total Kilowatts
MI Voltage Unbalance %_1	0	Data E...	74...75		MI Voltage Unbalan...
MI Current Unbalance %_1	0	Data E...	76...77		MI Current Unbalan...
MI Error Code_1	0	Data E...	78...79		MI Error Code

In the Project Tree shown below, select the arrow to the left of PLC Tags to reveal the categories below it.

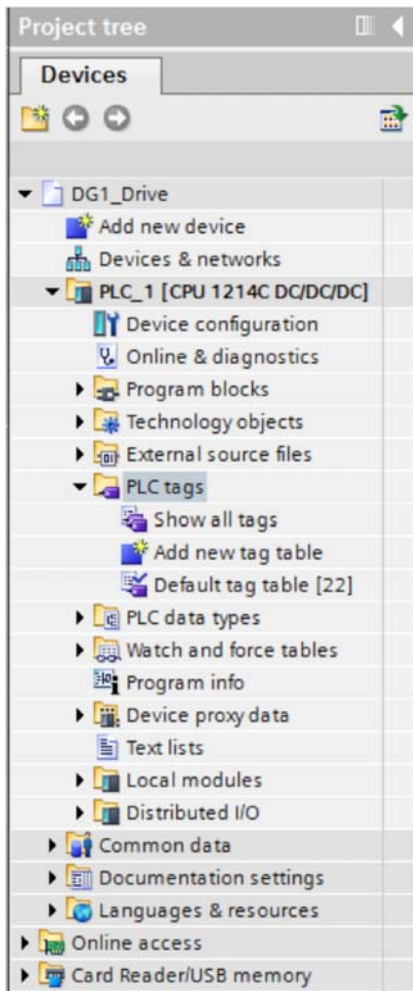

# Application Example: Operating a C441 Motor Insight with a Siemens PLC on PROFIBUS-DP

Double click "Show all tags" under PLC Tags to display the following:

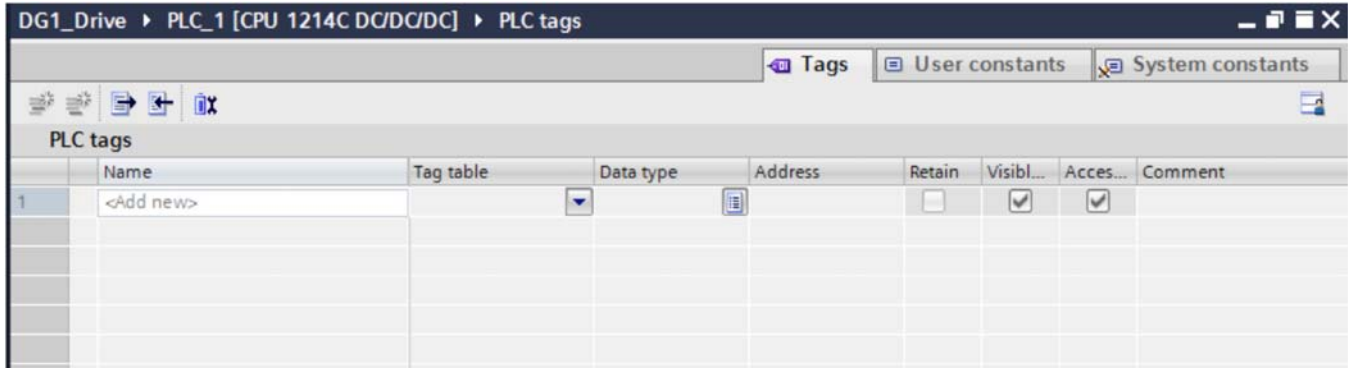

Double click in the top row under the Address column and begin entering the I/O addresses for the C441 Motor Insight as shown below:

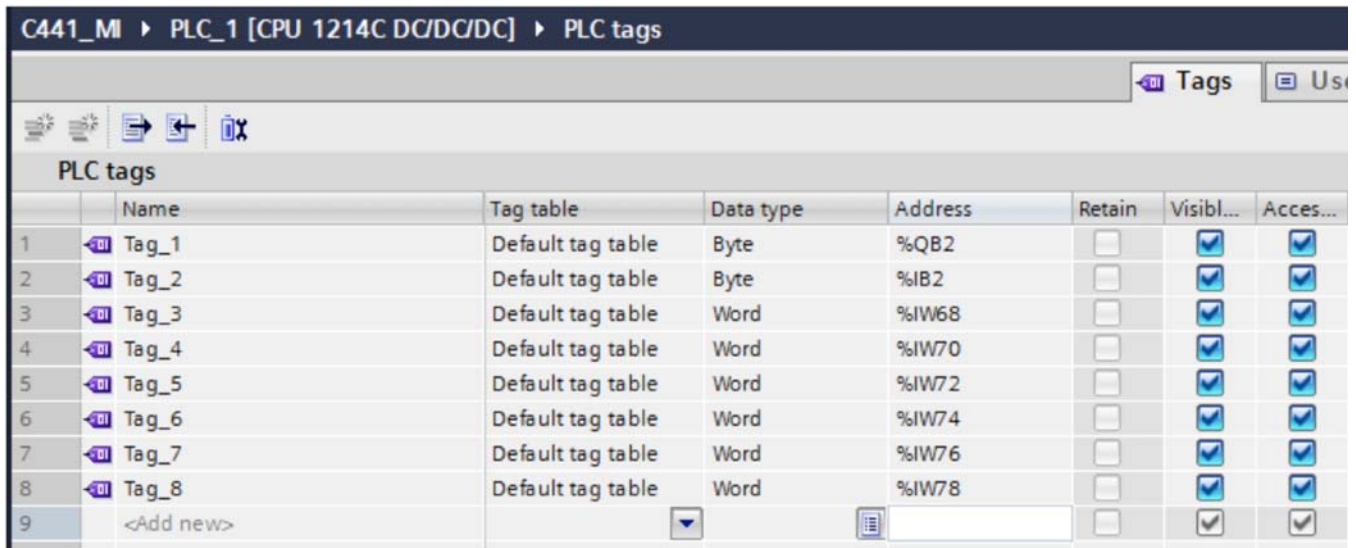

Note that the software puts % in front of these addresses. There is no need to enter it when entering the addresses.



## Application Example: Operating a C441 Motor Insight with a Siemens PLC on PROFIBUS-DP

Now add Tag names to these addresses as follows:

	Name	Tag table	Data type	Address	Retain	Visibl...	Acces...
1	Outputs	Default tag table	Byte	%QB2	<input type="checkbox"/>	<input checked="" type="checkbox"/>	<input checked="" type="checkbox"/>
2	Inputs	Default tag table	Byte	%IB2	<input type="checkbox"/>	<input checked="" type="checkbox"/>	<input checked="" type="checkbox"/>
3	Average_Current	Default tag table	Word	%IW68	<input type="checkbox"/>	<input checked="" type="checkbox"/>	<input checked="" type="checkbox"/>
4	Average_Voltage	Default tag table	Word	%IW70	<input type="checkbox"/>	<input checked="" type="checkbox"/>	<input checked="" type="checkbox"/>
5	Total_KW	Default tag table	Word	%IW72	<input type="checkbox"/>	<input checked="" type="checkbox"/>	<input checked="" type="checkbox"/>
6	Voltage_%Unbalance	Default tag table	Word	%IW74	<input type="checkbox"/>	<input checked="" type="checkbox"/>	<input checked="" type="checkbox"/>
7	Current_%Unbalance	Default tag table	Word	%IW76	<input type="checkbox"/>	<input checked="" type="checkbox"/>	<input checked="" type="checkbox"/>
8	Error_Code	Default tag table	Word	%IW78	<input type="checkbox"/>	<input checked="" type="checkbox"/>	<input checked="" type="checkbox"/>
9	<Add new>				<input type="checkbox"/>	<input checked="" type="checkbox"/>	<input checked="" type="checkbox"/>

The tag names should fit the application. The tag names used above are just an example.

Next, double click "Add new watch table" under "Watch and Force tables" in the Project Tree on the left per the following:

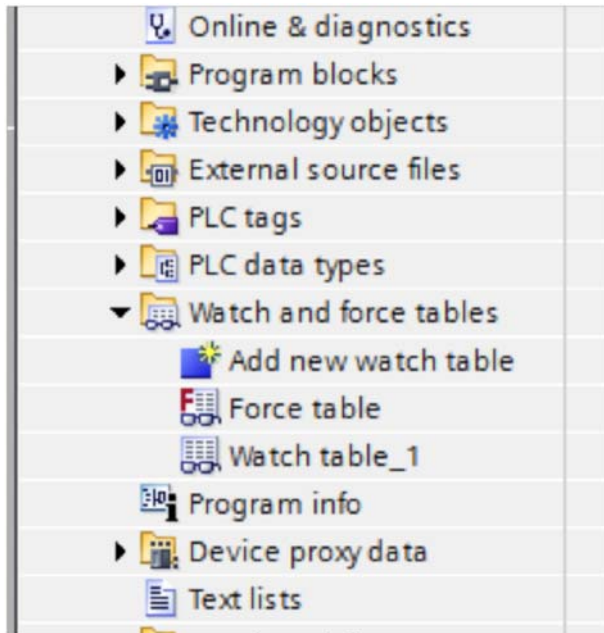

In the new watch table that should now be displayed, add the I/O addresses for the C441 Motor Insight. Note that the names for these addresses that you entered into the PLC Tags area are automatically populated as the addresses are entered. This watch table will allow testing the C441 Motor Insight over PROFIBUS without writing a program. This will allow monitoring the input data from the C441 Motor Insight, while operating the C441Q/S outputs.

C441\_MI ▶ PLC\_1 [CPU 1214C DC/DC/DC] ▶ Watch and force tables ▶ Watch table\_1

	Name	Address	Display format	Monitor value	Modify value
1	*Inputs*	%IB2	Hex		
2	*Outputs*	%QB2	Hex		
3	*Average_Current*	%IW68	Hex		
4	*Average_Voltage*	%IW70	Hex		
5	*Total_KW*	%IW72	Hex		
6	*Voltage_%Unbal...	%IW74	Hex		
7	*Current_%Unbal...	%IW76	Hex		
8	*Error_Code*	%IW78	Hex		
9		<Add new>			

## Downloading the Program to the Siemens S7 PLC

The project must first be compiled with no errors before it is downloaded to the PLC. In the Project Tree under PLC\_1 [CPU...], double click "Device configuration" as follows to display the Device View containing the PLC.

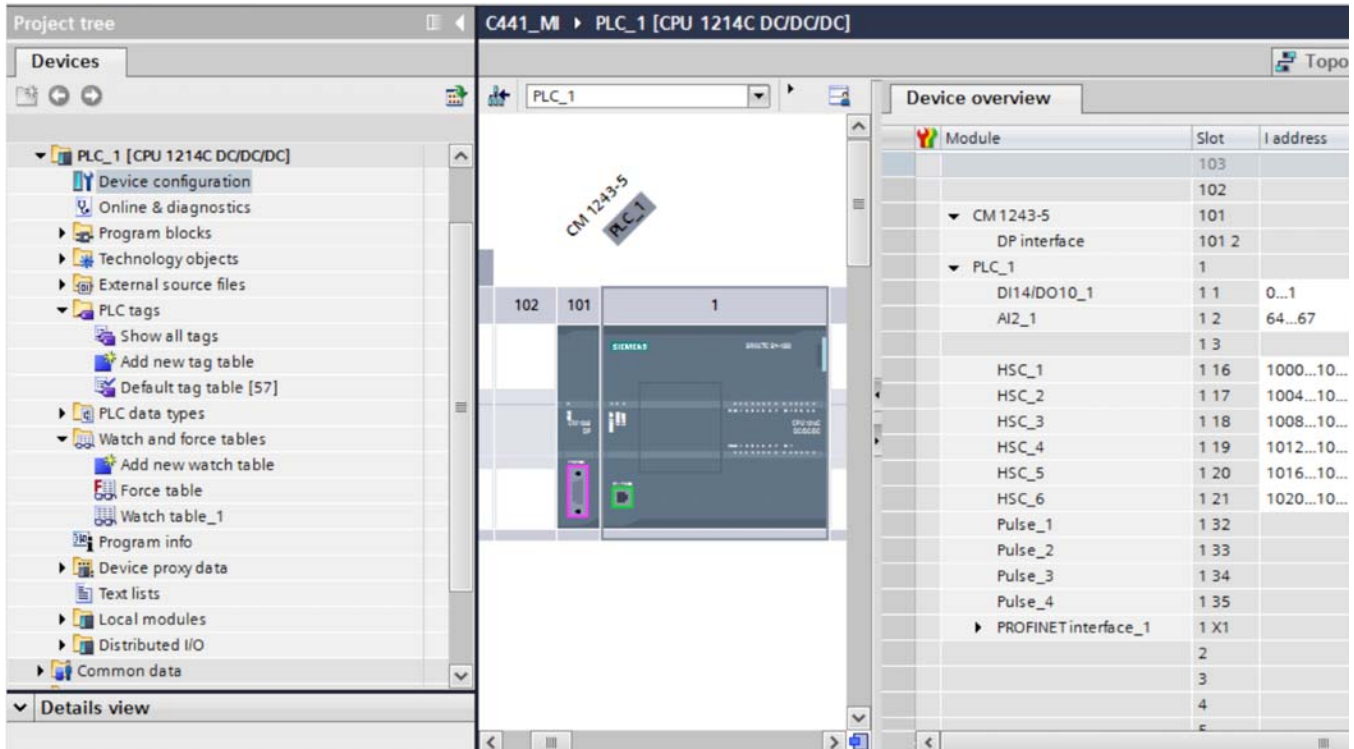

Select the PLC then click the Compile button. The compile button is just to the left of the Download button on the tool bar. Shown below are, from left to right: Compile button, download button and the upload button. As you hover over each of these buttons in the software, it will display its function.

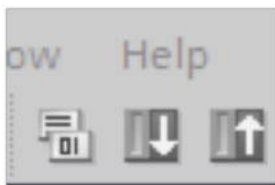

## Application Example: Operating a C441 Motor Insight with a Siemens PLC on PROFIBUS-DP

The results of the compile process will be displayed in the area below the PLC as follows:

The screenshot displays the SIMATIC Manager interface for a Siemens PLC system. The main window shows the hardware configuration of a rack with three slots. Slot 102 contains a CM 1243-5 module, slot 101 contains a DP interface module, and slot 1 contains the CPU 1214C DC/DC/DC module. The 'Device overview' table on the right provides a detailed list of modules and their addresses.

Module	Slot	I address	Q address	Type	Order no.
	103				
	102				
CM 1243-5	101			CM 1243-5	6GK7 243-5DX30-0X
DP interface	101 2			DP interface	
PLC_1	1			CPU 1214C DC/DC/DC	6ES7 214-1AG31-0X
DI14/DO10_1	1 1	0...1	0...1	DI14/DO10	
AJ2_1	1 2	64...67		AJ2	
	1 3				
HSC_1	1 16	1000...10...		HSC	
HSC_2	1 17	1004...10...		HSC	
HSC_3	1 18	1008...10...		HSC	
HSC_4	1 19	1012...10...		HSC	
HSC_5	1 20	1016...10...		HSC	
HSC_6	1 21	1020...10...		HSC	
Pulse_1	1 32		1000...10...	Pulse generator (PTO/P...	
Pulse_2	1 33		1002...10...	Pulse generator (PTO/P...	
Pulse_3	1 34		1004...10...	Pulse generator (PTO/P...	
Pulse_4	1 35		1006...10...	Pulse generator (PTO/P...	
PROFINET interface_1	1 X1			PROFINET interface	
	2				
	3				
	4				
	5				

The 'Compile' window at the bottom shows the following status:

Compiling completed (errors: 0; warnings: 0)

Path	Description	Go to ?	Errors	Warnings	Time
PLC_1			0	0	12:06:17 PM
Hardware configuration			0	0	12:06:17 PM
Program blocks			0	0	12:06:24 PM
Main (OB1)	Block was successfully compiled.		0	0	12:06:24 PM
	Compiling completed (errors: 0; warnings: 0)		0	0	12:06:27 PM

## Application Example: Operating a C441 Motor Insight with a Siemens PLC on PROFIBUS-DP

Next, select the download button to download the project to the PLC. The following window will be displayed. If the controller was in the Run mode, it must be stopped for the download. Select "Stop all" per the following, then select the Load button.

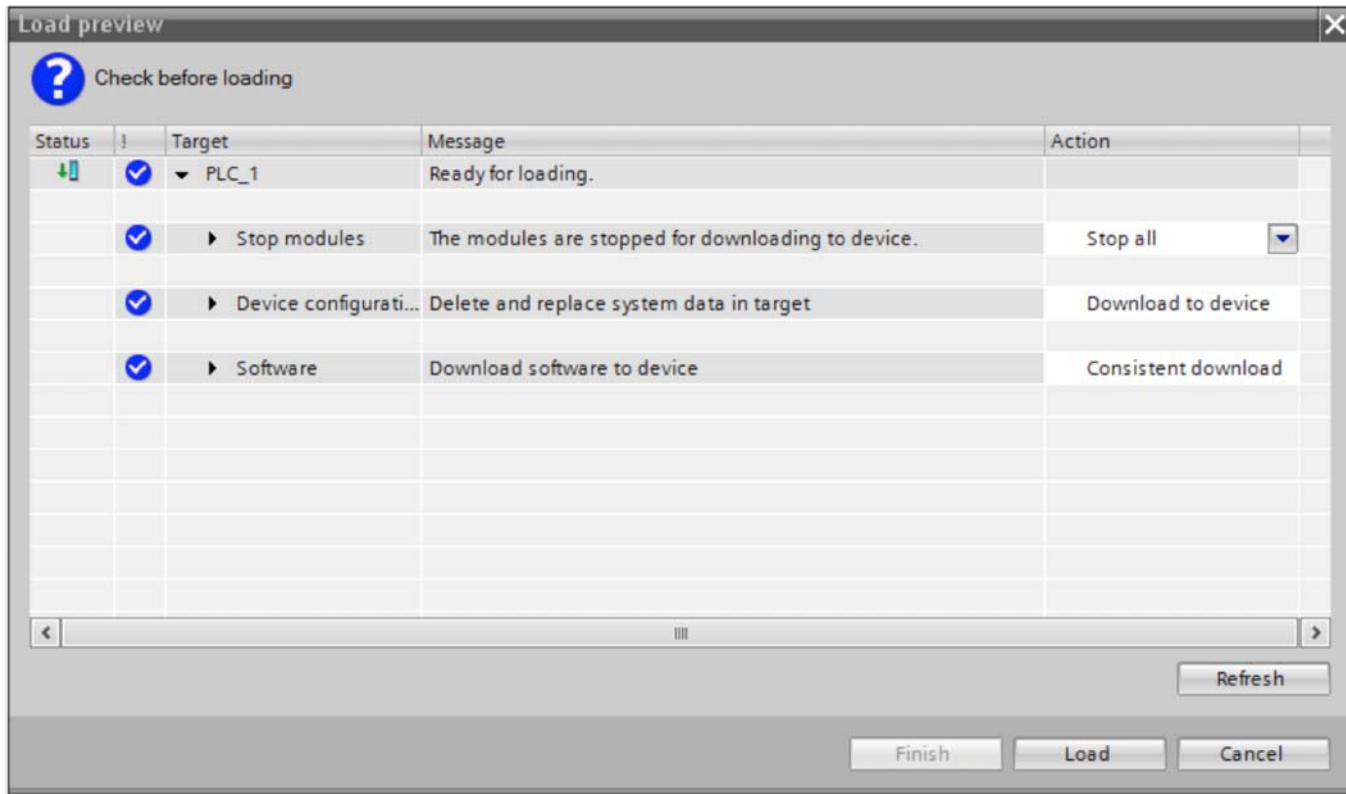

## Application Example: Operating a C441 Motor Insight with a Siemens PLC on PROFIBUS-DP

The results of the Load will be displayed in the lower portion of the project screen as shown below. "Start all" should be selected, then select the Finish button. This will complete the download and place the PLC into the Run mode per the following:

The screenshot displays the Siemens SIMATIC Manager interface. The main window title is "C441\_MI > PLC\_1 [CPU 1214C DC/DC/DC]". The "Device overview" table is visible in the background, showing module slots and addresses. The "Load results" dialog box is open, displaying the following table:

Status	Target	Message	Action
↓	PLC_1	Downloading to device completed without error.	
!	▶ Start modules	Start modules after downloading to device.	<input checked="" type="checkbox"/> Start all

At the bottom of the dialog box are buttons for "Finish", "Load", and "Cancel". Below the dialog box, the "Message" log shows the following entries:

Message	Go to ?	Date	Time
Project C441_MI opened.		10/17/2014	7:34:54 AM
Start downloading to device.		10/17/2014	7:51:53 AM
PLC_1		10/17/2014	7:51:53 AM
Hardware configuration		10/17/2014	7:53:14 AM
PLC_1 stopped.		10/17/2014	7:53:41 AM
Hardware configuration was loaded successfully.		10/17/2014	7:53:51 AM

## Application Example: Operating a C441 Motor Insight with a Siemens PLC on PROFIBUS-DP

With the PLC selected, select “Go online” from the Tool Bar to go online with the project running in the PLC.

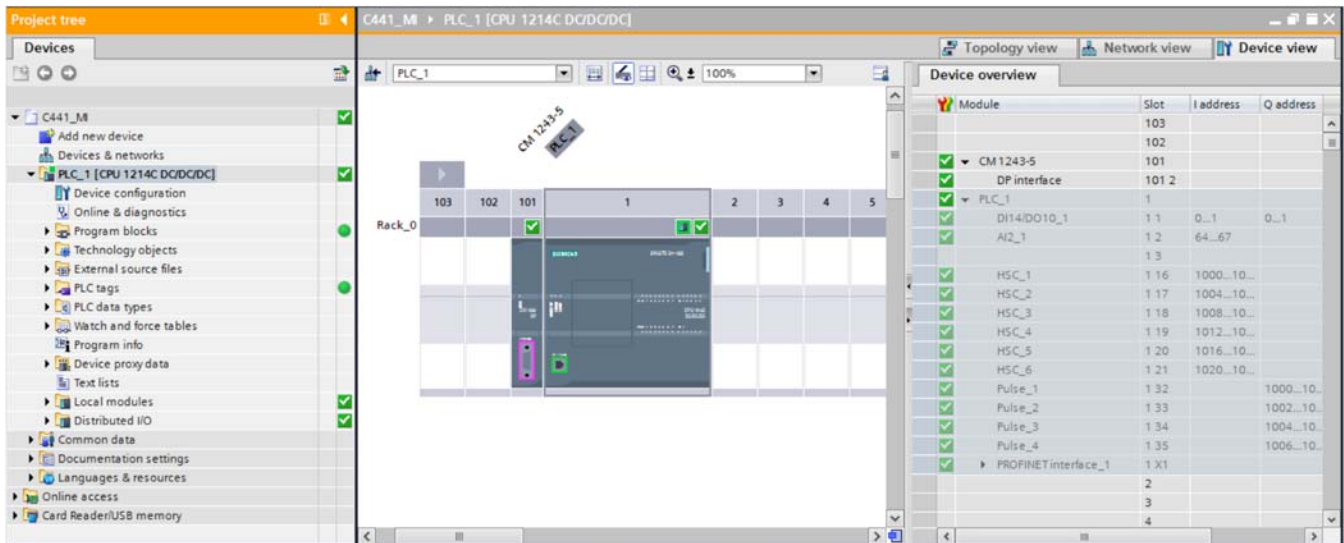

When online, the Simatic software should look like the following:

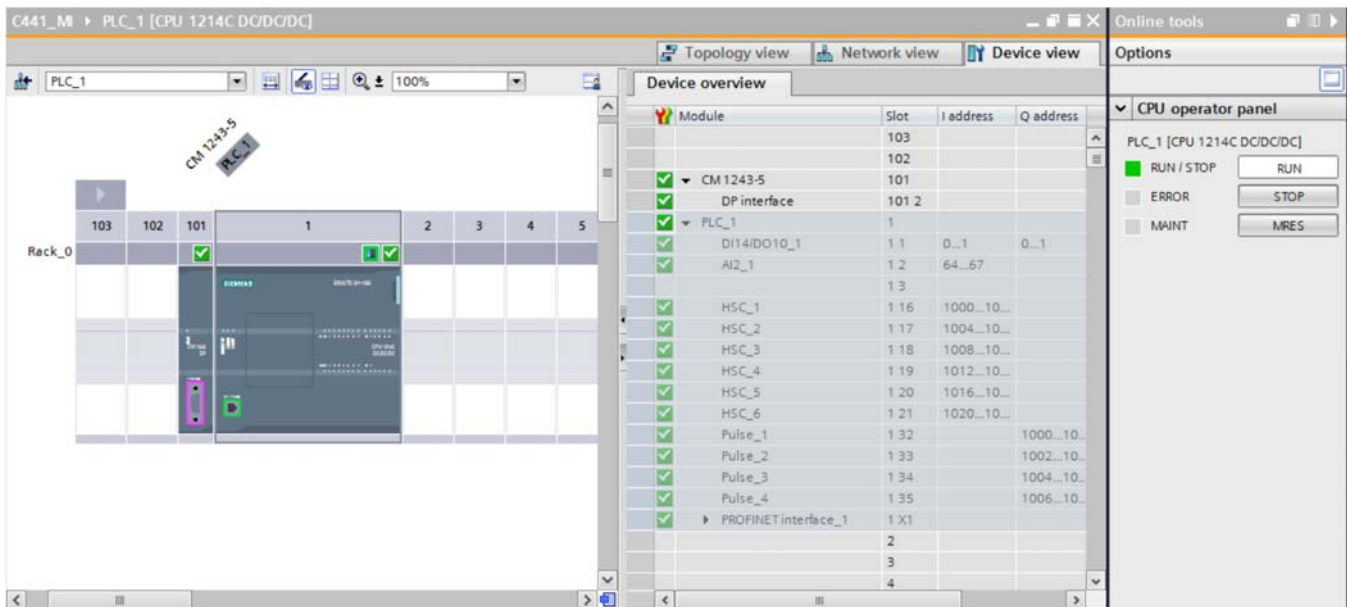

# Application Example: Operating a C441 Motor Insight with a Siemens PLC on PROFIBUS-DP

In the Project Tree on the left, double click "Watch table\_1" under "Watch and force tables" to display the following:

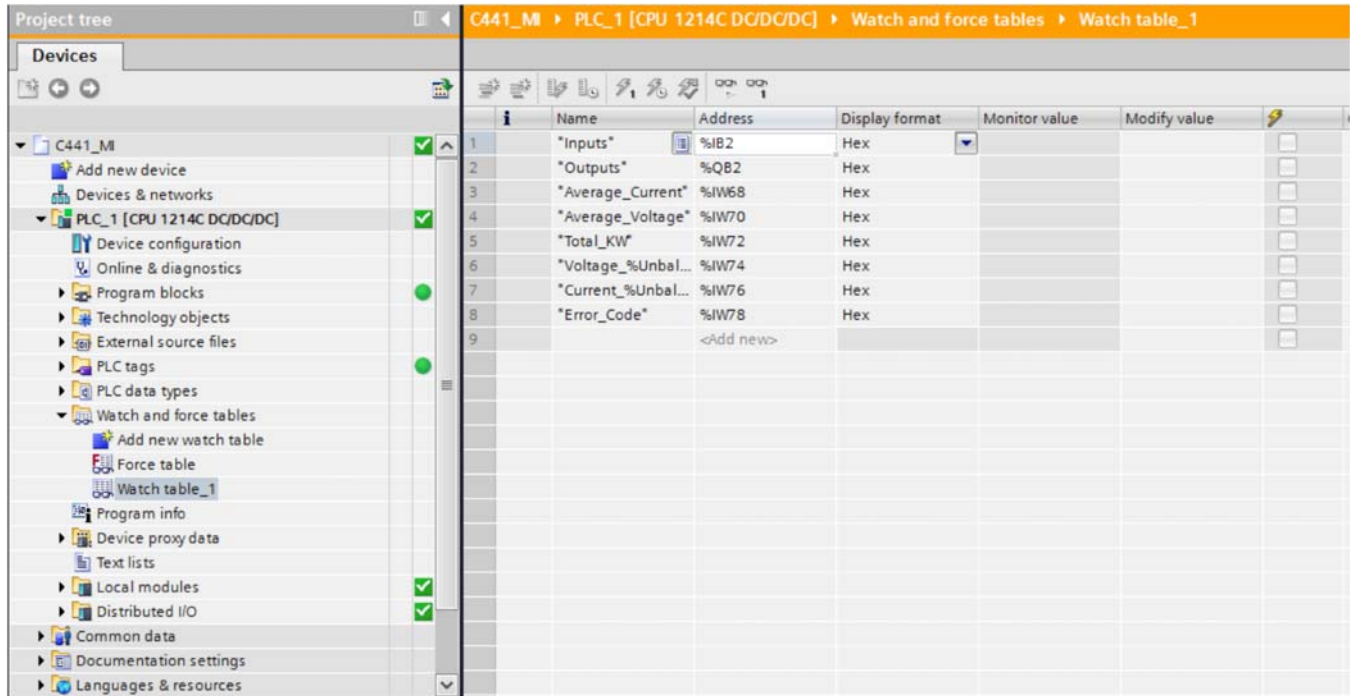

Below is the Tool Bar located above the Watch List.



If the second icon from the right is selected, the Watch List will begin monitoring and displaying the I/O data as follows:

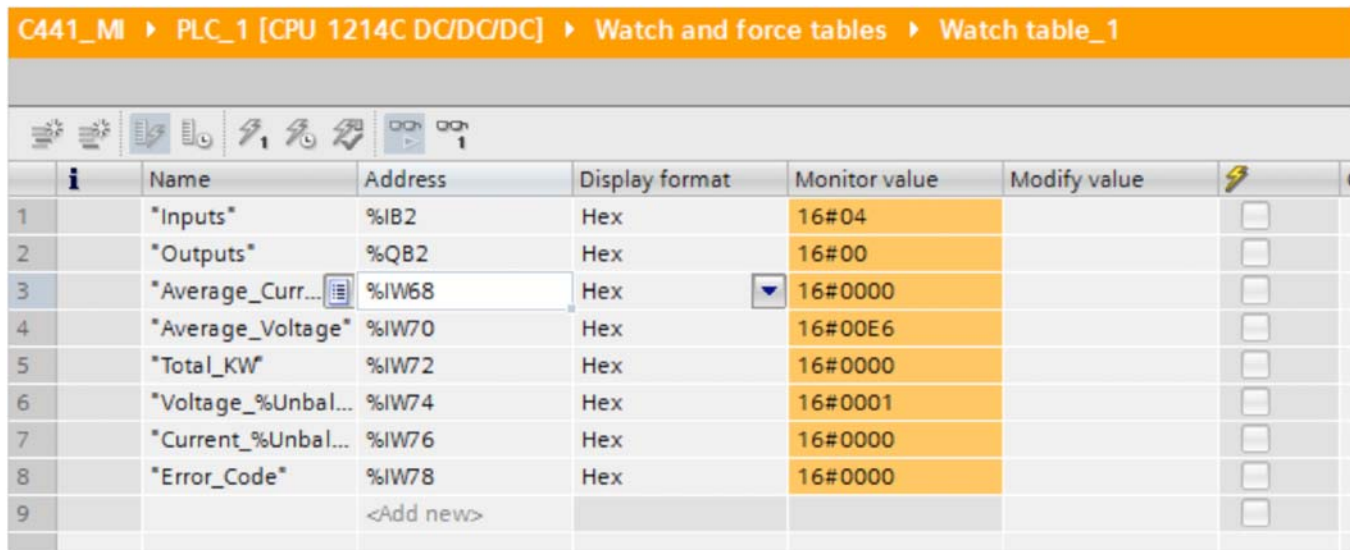



## Application Example: Operating a C441 Motor Insight with a Siemens PLC on PROFIBUS-DP

In the “Modify value” column for QB2 enter a 1 to energize Output1 and a 0 to de-energize Output1. If the system is wired to the motor as described earlier in the document, when Output1 is energized, the motor will Run.

The data can be entered/viewed in different formats by changing the Display Format for any value.

Each time values are entered or modified in the “Modify Value” column for the Outputs tag, the lightning bolt with a 1 under it shown below must be selected to instruct the software and the PLC to write the value to the C441 Motor Insight.



Refer to the PROFIBUS Chapter in the C441 Motor Insight User Manual (publication MN04209001E) for additional information on the configuration, control and monitoring parameters, Fault Codes and more.

### References

C441 Motor Insight User Manual, Publication MN04209001E

### Additional Help

In the US or Canada: please contact the Technical Resource Center at 1-877-ETN-CARE or 1-877-326-2273 option 2, option 6.

All other supporting documentation is located on the Eaton website at [www.eaton.com/Drives](http://www.eaton.com/Drives)





Eaton is dedicated to ensuring that reliable, efficient and safe power is available when it's needed most. With unparalleled knowledge of electrical power management across industries, experts at Eaton deliver customized, integrated solutions to solve our customers' most critical challenges.

Our focus is on delivering the right solution for the application. But, decision makers demand more than just innovative products. They turn to Eaton for an unwavering commitment to personal support that makes customer success a top priority. For more information, **visit [www.eaton.com/electrical](http://www.eaton.com/electrical)**.

**Eaton**  
1000 Eaton Boulevard  
Cleveland, OH 44122  
United States  
[Eaton.com](http://Eaton.com)

© 2015 Eaton  
All Rights Reserved  
Printed in USA  
Publication No. MN042002EN / Z16730  
July 2015

Eaton is a registered trademark.

All other trademarks are property of their respective owners.

