

PROFIBUS Module for use with Motor Insight, C440 and S611

Installation

The PROFIBUS module is designed to be used in industrial applications and installed in accordance with this document.

Mount the Module

To mount the PROFIBUS adapter to Motor Insight® or C440-COM-ADP the following procedure must be preformed.

- Place the tabs opposite the PROFIBUS connector into the lower slots provided on the Motor Insights right side.
- Pivot the module on the lower tabs toward the Motor Insight.
- Gently press the module and Motor Insight together.

Connect the PROFIBUS Adapter to PROFIBUS

Connect the PROFIBUS terminal to the PROFIBUS DB9 connector located on the side of the module. The connector has screws for positive retention to eliminate accidental unplugging.

Connect 24 Vdc control power to the 5-position header.

- The connector has screws for positive retention to eliminate accidental unplugging.
- Use one wire per terminal.

Set the PROFIBUS address

The PROFIBUS address is set using the DIP switches located on the face of the module. The PROFIBUS address is binary with the major units numbered to the left of the switch on the side label. Adding up the major units set to ON determines the address of the module.

Example: To set the address to 25, start from the switch mark 32 and set the switches to Off (32), ON (16), ON (8), OFF (4), OFF (2) ON (1) (16+8+1=25).

Note: Address is only updated upon power up.

The PROFIBUS baud rate is set automatically using an auto baud technology, there is no need to set the baud rate. For more information on the PROFIBUS attributes and how to modify them, refer to the appropriate user manual. Motor Insight MN04209001E, C440 MN04201001E or S611 MN03902011E.

The GSD file is located on the Eaton web site, go to www.eaton.com.

C441S - 120 Vac Input Specification

Example: 120V ac IO Module
- All inputs are isolated.
- All common terminals are connected together internally.

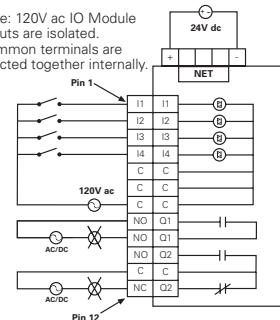

Specification	Value
Number of Inputs	4
Nominal Voltage	120 Vac
Nominal Current	15mA
Operating Frequency	50/60Hz
Signal Delay max.	30ms
Input type	IEC 61131-2 Type 1 Digital

C441Q - 24 Vdc Input Specification

Example: Non Isolating 24V dc input Source
- Input source power is taken from 5 pin connector.
- Connect C and 0V together.
- Use 24 to source Inputs.

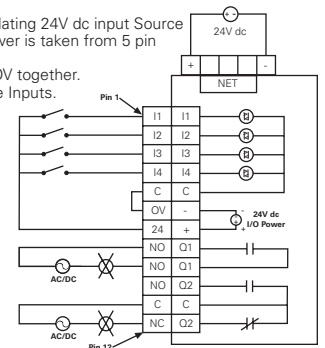

Example: Isolated 24V dc Input Source
- The inputs must be supplied by an external power source.
- Do not connect the external supply to terminals 0V and 24.
- Connect isolated power source between C and inputs.

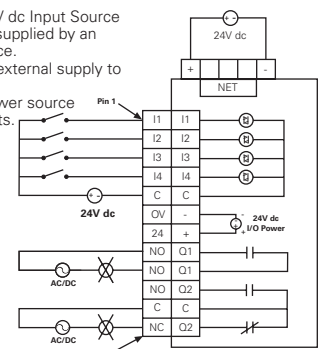

Powering Business Worldwide

Specification	Value
Number of Inputs	4
Nominal Voltage	24 Vdc
Nominal Current	5mA
Type	Current Sinking
Input Type	IEC 61131-2, Type 1 Digital
Max 24 Vdc Source Current	50mA

PROFIBUS Adapter Setup and Configuration

Configure C441 Profibus Adapter

1. Load the gsd file for the C441 Profibus Adapter into the Master's configuration tool.
2. Select and add the C441 Profibus Adapter to the network configuration.
3. The default configuration for the C441 Profibus Adapter is a StandAlone IO base. If the C441 Profibus Adapter is to connect to a base device; remove the modules from all 28 slots of the default configuration.
4. Select and add the attached device's base module to slot 1 of the C441 Profibus Adapter configuration.
NOTE: The appropriate base module MUST be placed in slot 1 of the configuration. Failure to do so will cause configuration to fail.
5. Select and add the desired modules for the data exchange into slots 2 - 28. Select only those modules supported by the base module (See the base device's user manual for a list of supported modules)

Example Configuration:

I/O module	Type	Description
C441 MotorInsight Base	base - no IO	Attached Device
Com Adapter Outputs	output - 1 byte	Controls C441 adapter outputs
MI Command Register	output - 2 bytes	Controls MI Relay-start/stop
Com Adapter Inputs	input - 1 byte	Status of C441 adapter inputs
MI RMS Current Ave	input - 2 bytes	Average rms current reading
MI RMS Voltage Ave	input - 2 bytes	Average rms voltage reading
MI Total Kilowatts	input - 2 bytes	Total power reading

Setup C441 Profibus Adapter Device Parameters

1. Select the C441 Profibus Adapter to display its device parameters.
2. Set the "Enable Device Parameters & Adapter Outputs ComLos Behavior" parameters.

Note: To enable writing of the device parameters into the attached base device "Enable Device Parameters" must be set to "Download Device Parameters".

Setup the Device Parameters

1. Select the base module in the configuration to display its device parameters. The base module contains the parameters to enable/disable faults, set thresholds, etc. for the attached device.

Example: The following parameters can be found in C441 MotorInsight Base Module

- CT Multiplier
- Overload FLA
- Overload Trip Class
- GND Fault Trip Level
- Low KW Trip Level
- High KW Trip Level
- Under Voltage Trip Level
- Over Voltage Trip Level

After all configuration is complete, save and download the new configuration settings to the Master(PLC) & C441 Profibus Adapter.

Profibus Diagnostics

The C441 Profibus Adapter provides the user with status information along with fault and warning data relevant to the operation of the attached base module. Fault and warning information is presented to the user through extended diagnostics. All fault information is sent to the Master as high priority diagnostic messages (ext. diag. bit set in diagnostic message). All warning information is sent as low priority diagnostic messages (ext diag. bit clear). Low priority diagnostic messages are issued as the fault condition clears. See the User Manual for the attached base module's diagnostic message bit definitions

Environmental Ratings of the Module

Transportation and Storage	Temperature	-40°C to 85°C (-40°F to 185°F)
	Humidity	5 - 95 % non-condensing
Operating	Temperature	-20°C to 50°C (-4°F to 122°F)
	Humidity	5 - 95 % non-condensing
	Altitude	Above 2000meters (6600feet) consult factory
	Shock ICE 60068-2-27	15G any direction for 11 milliseconds
	Vibration IEC 60068-2-6	3G in any direction
	Polution Degree	3

Approvals / Certifications

Electrical / EMC	
ESD Immunity	+/- 8kV air, +/- 4kV contact
Radiated Immunity (IEC61000-4-3)	10V/m 80-1000 MHz, 80% amplitude modulation @ 1kHz
Fast Transient (IEC61000-4-4)	+/- 2kV communications
Surge (IEC61000-4-5)	+/- 2kV shield-to-ground
RF Conducted (IEC61000-4-6)	10V, 0.15 – 80MHz
Ingress Protection Code	IP20
Radiated and Conducted Emissions	EN55011 (CISPR 11) Class A
Agency Certifications	UL® 508 cUL® (CSA C22.2 No. 14) CE (Low Voltage Directive) PROFIBUS Certification ✓ RoHS

Module Electrical Requirements

Voltage Range	18 - 30 Vdc
Current Draw	Approx. 30 mA

Notes

For use with Eaton UL Listed Power Supply Catalog Nos. PSS55A, PSS55B, PSS55C, or PS160E.

Any UL Listed isolated power supply with a maximum of 30 Vdc output may be used, provided that a UL Listed or Recognized Fuse rated no more than 3A maximum be installed.

5pin 24 VDC Power, RS485 Connector

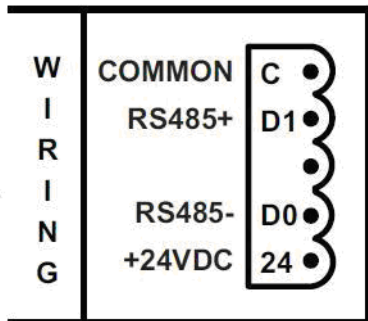

CURRENT DRAW: 30mA
TERMINAL TORQUE:
.25 Nm (2.25 lb-in)

Eaton Corporation
Electrical Sector
1000 Cherrington Parkway
Moon Township, PA 15108
United States
877-ETN-CARE (877-386-2273)
Eaton.com

© 2009 Eaton Corporation
All Rights Reserved
Printed in USA
Publication No. IL04209006E
July 2010, Rev. 007

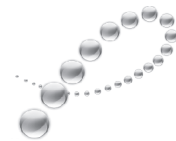

**PowerChain
Management®**

PowerChain Management is a registered
trademark of Eaton Corporation.

All other trademarks are property of their
respective owners.