

# TechBench™

## Installation manual



*Powering Business Worldwide*

Table of Contents

# TechBench™ Installation Manual

## Table of Contents

TechBench™ Overview ..... 3

Bench Assembly – Linear, 36" (914,4mm) Wide – 96" (2438,4mm) Wide..... 4-8

Bench Assembly – Linear, 24" (609,6mm) Wide – 30" (762mm) Wide..... 9-10

Bench Assembly – Corner 48" (1219,2mm) x 48" (1219,2mm)..... 11-19

# TechBench Overview

- **TechBenches** are available with a 1.75" (44,5mm) thick Maple work surface, a 1.20" (30,5mm) thick Laminate work surface and a 0.75" (19,1mm) thick Phenolic work surface.
- **The TechBench** height can be set at 1.00" (25,4mm) increments.
- **TechBench** (with adjustable height feature)\* height range:
  - Maple:** 34" (863,6mm) to 38" (965,2mm)
  - Laminate:** 33" (838,2mm) to 37 -3/8" (949,3mm)
  - Phenolic:** 32" (812,8mm) to 36" (914,4mm)
- \* These heights include the four glide feet adjusted 2-1/2" (63,5mm) from the bottom of the frame to the floor.
- **TechBench** maximum load capacity (evenly distributed):
  - Maple:** 2000 lbs. (4400 kg)
  - Laminate:** 2000 lbs. (4400 kg)
  - Phenolic:** 1200lbs. (2640 kg)

## DISCLAIMER OF WARRANTIES AND LIMITATION OF LIABILITY

The information, recommendations, descriptions and safety notations in this document are based on Eaton Corporation's ("Eaton") experience and judgment and may not cover all contingencies. If further information is required, an Eaton sales office should be consulted. Sale of the product shown in this literature is subject to the terms and conditions outlined in appropriate Eaton selling policies or other contractual agreement between Eaton and the purchaser.

THERE ARE NO UNDERSTANDINGS, AGREEMENTS, WARRANTIES, EXPRESSED OR IMPLIED, INCLUDING WARRANTIES OF FITNESS FOR A PARTICULAR PURPOSE OR MERCHANTABILITY, OTHER THAN THOSE SPECIFICALLY SET OUT IN ANY EXISTING CONTRACT BETWEEN THE PARTIES. ANY SUCH CONTRACT STATES THE ENTIRE OBLIGATION OF EATON. THE CONTENTS OF THIS DOCUMENT SHALL NOT BECOME PART OF OR MODIFY ANY CONTRACT BETWEEN THE PARTIES.

In no event will Eaton be responsible to the purchaser or user in contract, in tort (including negligence), strict liability or otherwise for any special, indirect, incidental or consequential damage or loss whatsoever, including but not limited to damage or loss of use of equipment, plant or power system, cost of capital, loss of power, additional expenses in the use of existing power facilities, or claims against the purchaser or user by its customers resulting from the use of the information, recommendations and descriptions contained herein. The information contained in this manual is subject to change without notice.

**TOOLS REQUIRED**

- (1) 3/8" Socket wrench (not supplied)
- (1) 3/8" Socket (not supplied)
- (1) 9/16" Socket (not supplied)
- (1) #1 and #2 Magnetic tip phillips head bit (not supplied)
- (1) Electric drill (not supplied)
- (2) 1/2" Open end wrench (not supplied)
- (3) 1" Open end wrench (not supplied)
- (1) Grease (supplied)

**IMPORTANT SAFETY INSTRUCTIONS:**

- Two people are required to assemble the TechBench™
- Carefully follow instructions when adjusting the height.
- A minimum of three people are required to adjust the height of the work surface when the TechBench™ is in the upright position.

**CONNECTORS:**

- Connectors have two purposes:
- (1) Connecting two Linear and/or Corner benches together.
- (2) Installing a cable trough with or without connecting the benches together.

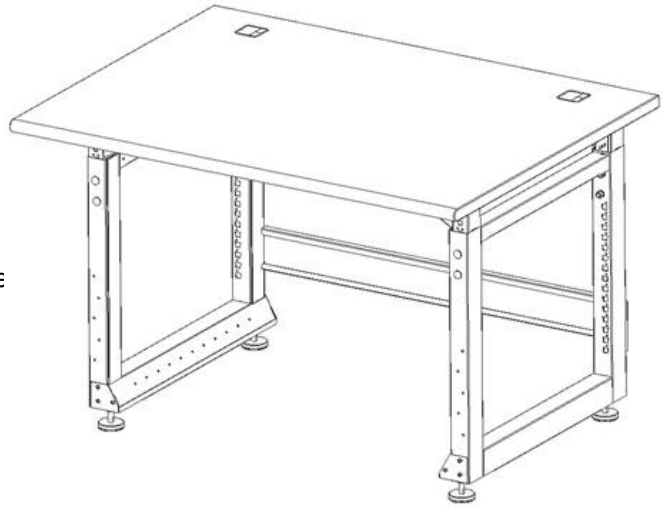

**LINEAR TECHBENCH™**

**LINEAR BENCH ASSEMBLY (36" [914,4mm] wide to 96" [2438,4mm] wide)**

1. With two people, carefully unpack the Worksurface and place it finished side down on the empty carton or on a clean carpeted surface.  
NOTE: Pre-drilled mounting holes in underside of Worksurface are visible.

2. Both sets of Upper and Lower Side Frames are pre-assembled at the factory. They must be unassembled before attaching them to the Worksurface. Remove the nuts, lock washers and carriage bolts and separate the Upper and Lower Side Frames. See figure 1.

**NOTE: Do not discard this hardware.** It will be used in **step 6**

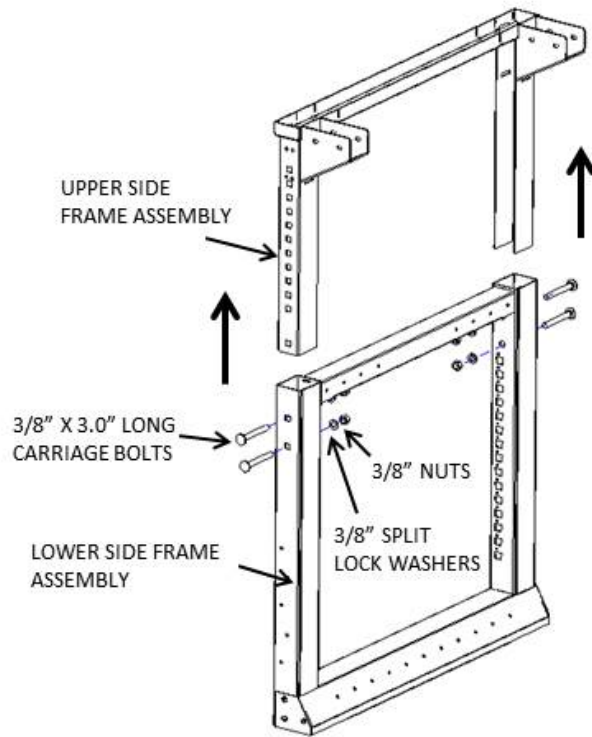

3. Assemble the Stiffener to the Upper Side Frames as shown in figures 2a and 2b. Slide the "tongue" at the end of the Stiffener into the slots on the top of the Upper Side Frames. Align the holes in the tongue with the holes in the top of the frame and secure using two 1/4"-20 x 1/2" long hex head screws. See figure 2b. Secure the gusset to the Stiffener using four 1/4"- 20 x 1/2" long hex head screws. Assemble Gusset Mounting to Upper Side frames using four 1/4"-20 x 1/2" long hex head screws.

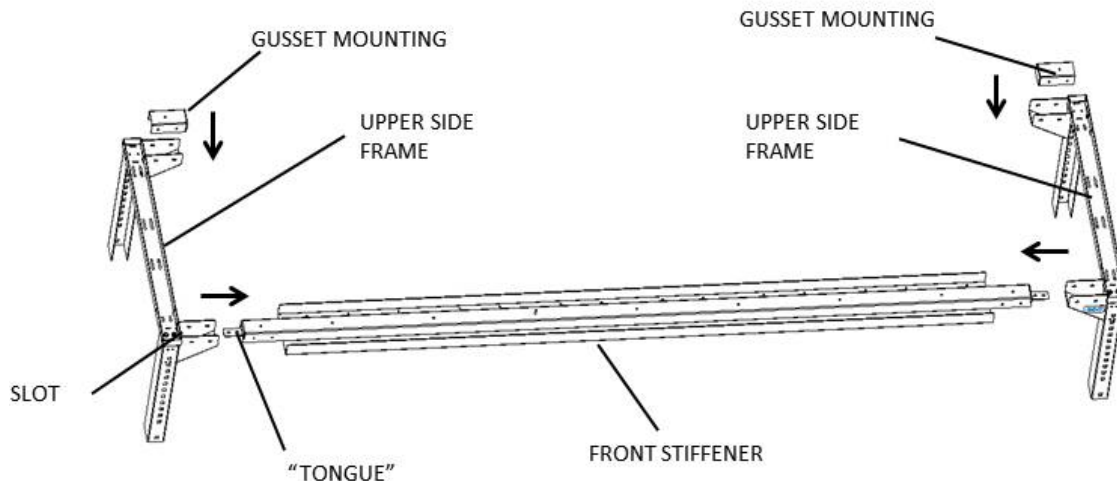

FIGURE 2a

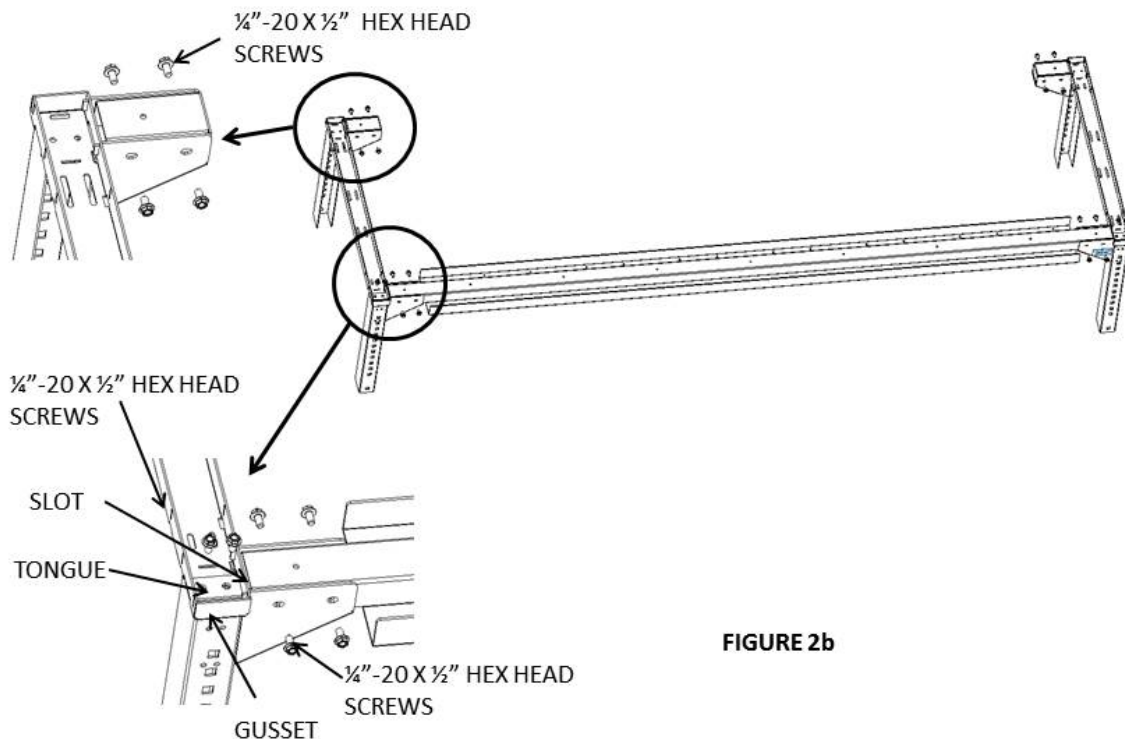
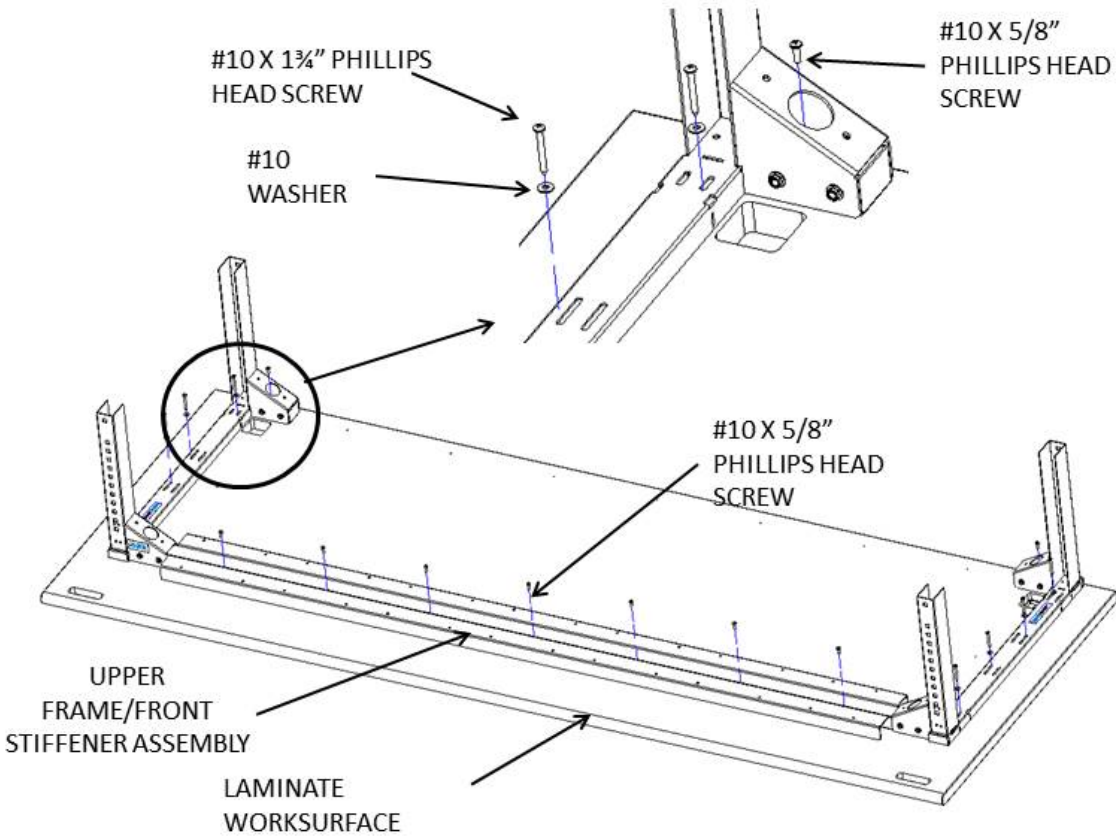
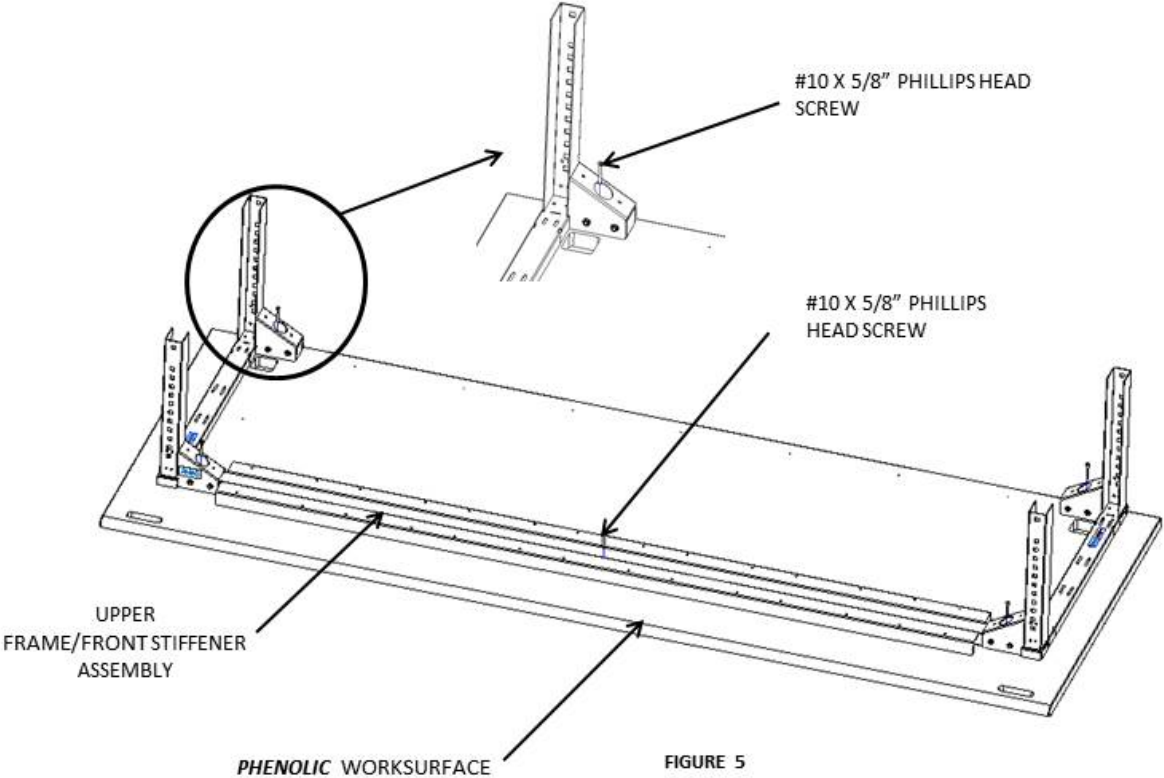
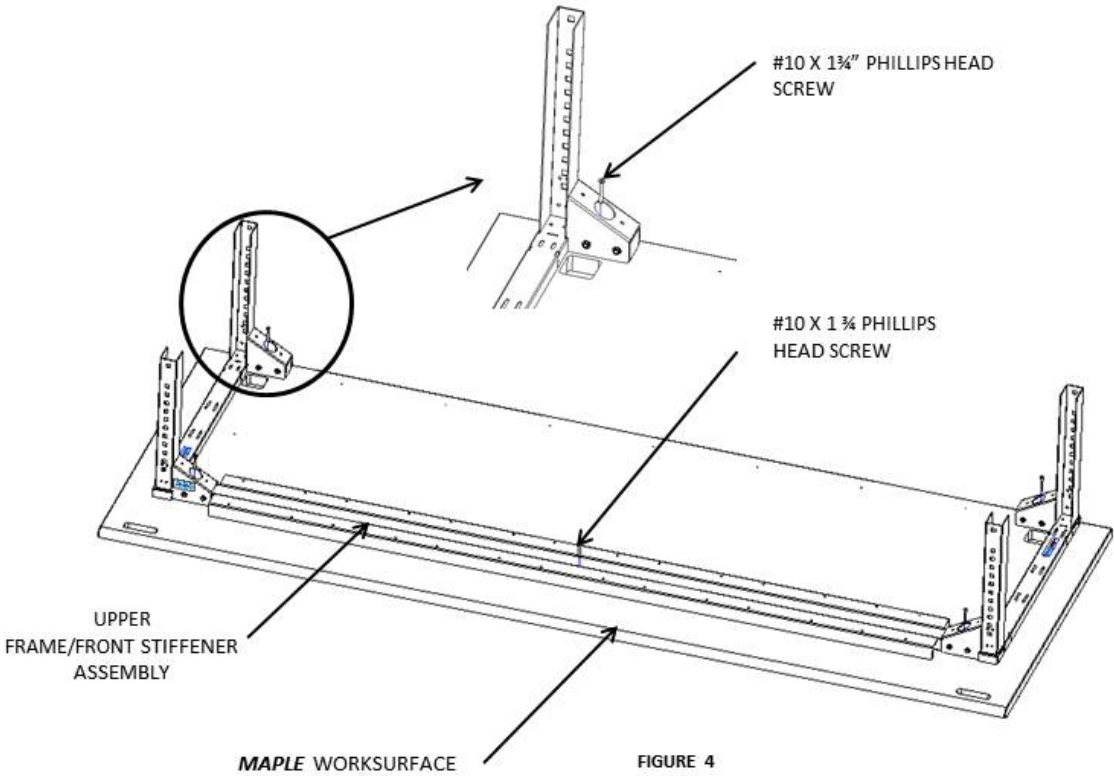

FIGURE 2b

4. Attach the Upper Frame assembly to the Linear Worksurface. Refer to charts on page 9 for types of hardware used for specific Worksurface types.



**FIGURE 3**  
LAMINATE WORKSURFACE  
SEE CHART ON PAGE 12



5. Reassemble the Lower Side Frames to the Upper Side Frames using the carriage bolts, washers and nuts previously removed in step 2. Adjust the Lower Side Frames for the desired height of the TechBench™ and re-install the hardware as shown in figure 6a.

6. NOTE: If installing Connector Brackets, see figures 7a,7b, 7c and 7d before reinstalling the Lower Side Frames.

7. Install the 4" Back Panel to the lower hole patterns in the Lower Side Frames using six 1/4"-20 x 1/2" long hex head screws. See figure 6a.

8. Adjust each Glide Foot to meet a nominal dimension of 2-1/2". See figure 7b. While holding the Glide Foot with a 1/2" open end wrench, tighten the check nut with a 1" open end wrench.

9. With a minimum of two people, carefully turn the TechBench™ assembly right side up.

## LEVELING

1. Level the TechBench™ by adjusting the levelers as required.

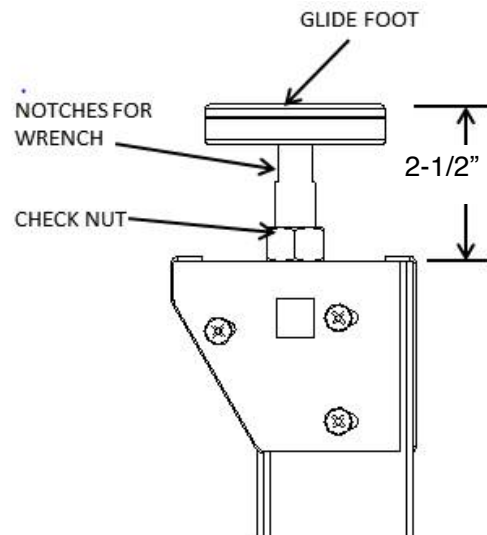

FIGURE 6B

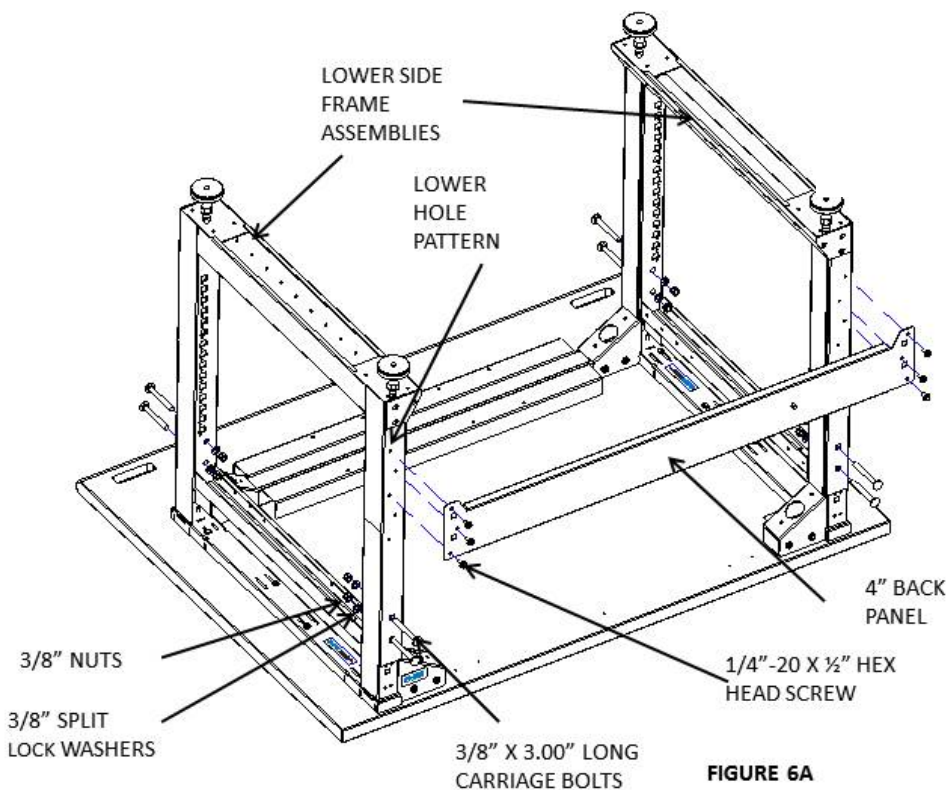
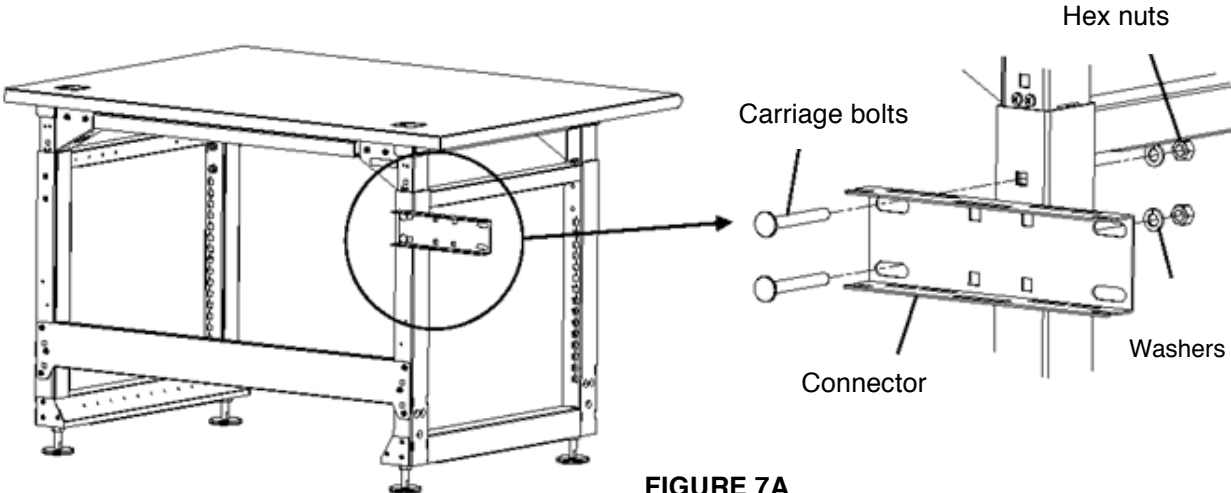

FIGURE 6A





**FIGURE 7A**

*Connector location when connecting two benches together and installing cable troughs.*

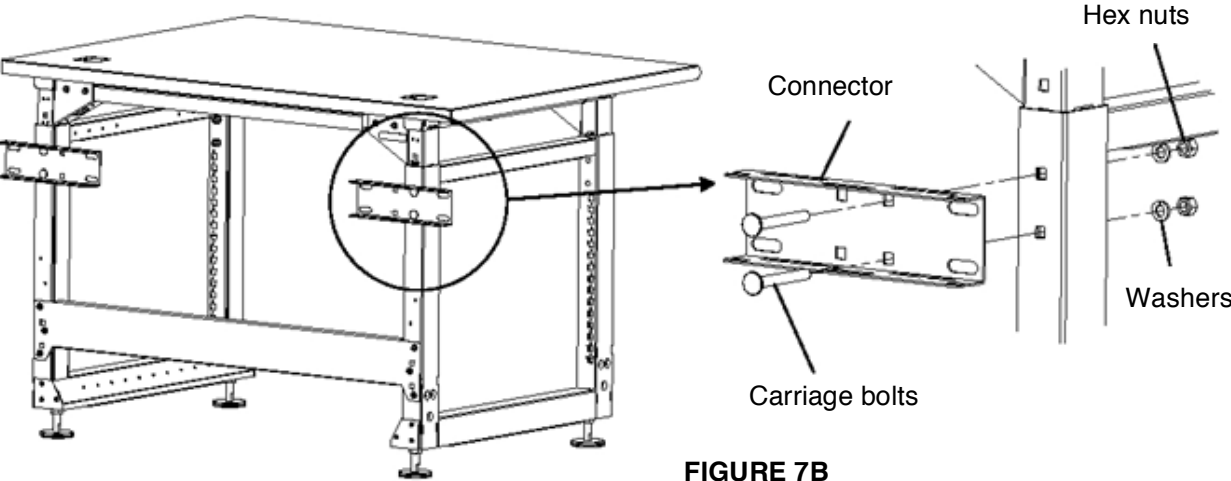

**FIGURE 7B**

*Cable trough installation only (single bench)*

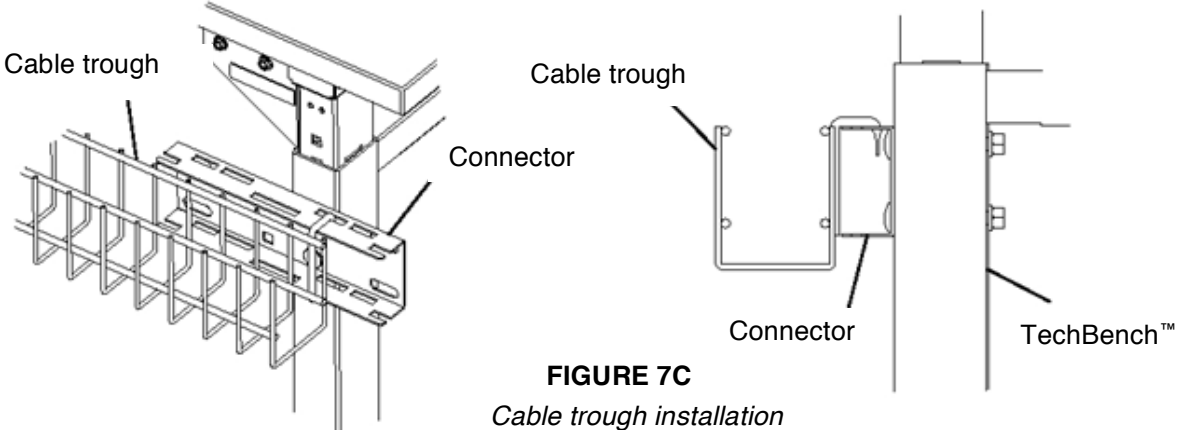

**FIGURE 7C**

*Cable trough installation*

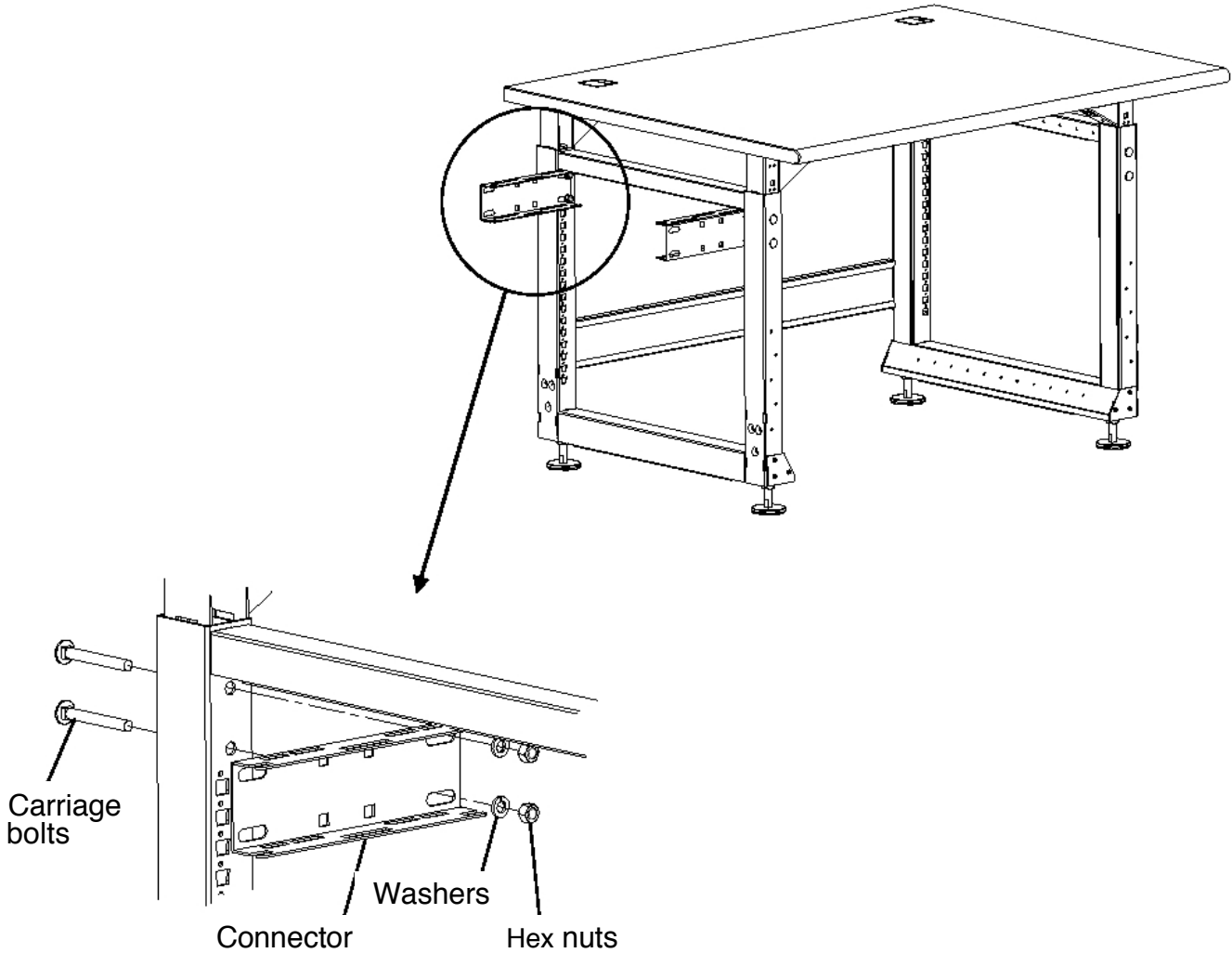
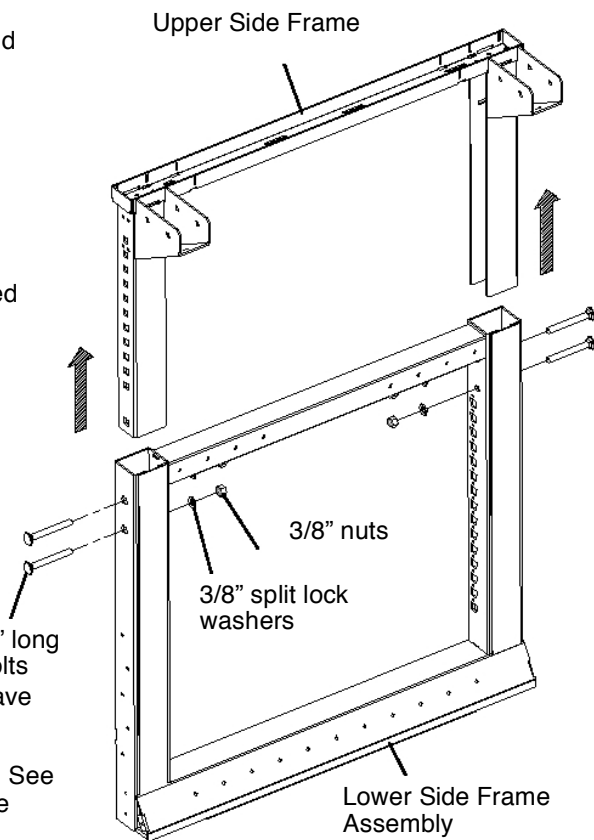

**FIGURE 7D**

*Connector location when connecting two benches together.*

**LINEAR BENCH ASSEMBLY (24" wide and 30" wide)**

1. With two people, carefully unpack the worksurface and place it finished side down on the empty carton or on a clean carpeted surface. **NOTE:** Pre-drilled mounting holes in underside of worksurface are visible.
2. Both sets of Upper and Lower Side Frames are pre-assembled at the factory. They must be unassembled before attaching them to the worksurface. Remove the nuts, lock washers and carriage bolts and separate the Upper and Lower Side Frames. See figure 8.
3. **NOTE: Do not discard this hardware.** It will be used in step 6.



**NOTE:** The 24" wide and 30" wide TechBenches do not have Stiffeners.

3. Assemble four Gusset Adapters to the Worksurface. See figure 9. Refer to charts on page 12 for type of hardware used for specific Worksurface types.
4. Assemble the Upper Side Frames to the Gusset Adapters using the 1/4"-20 x 1/2" hex head screws provided. See figure 10.
5. Attach the Upper Side Frames to the worksurface. See figure 10. Refer to charts on page 12 for type of hardware used for specific Worksurface types.

**FIGURE 8**

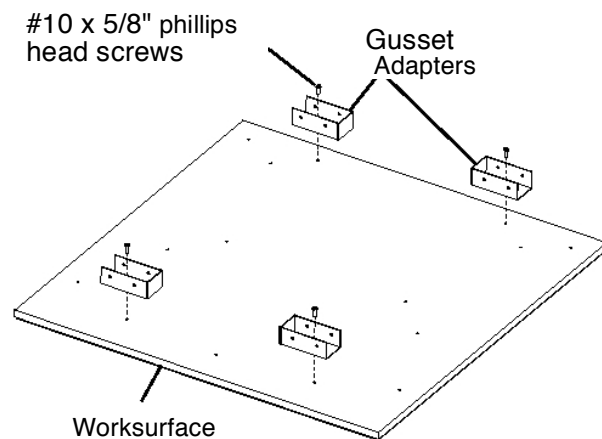

**FIGURE 9**

(see chart on page 12)

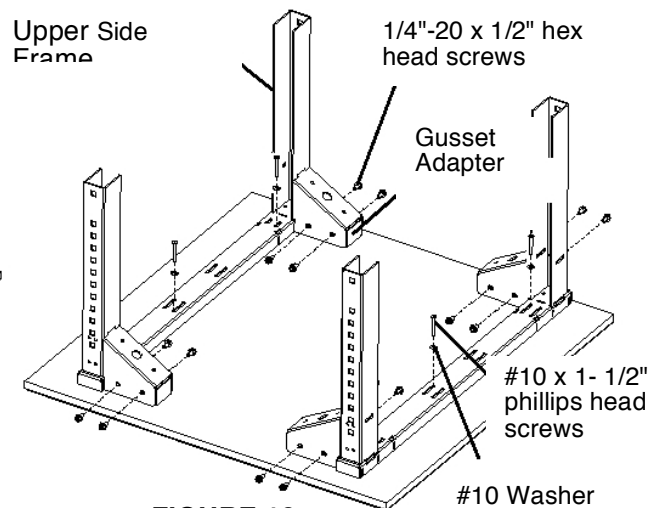

**FIGURE 10**

(see chart on page 12)

SCREW CHART-LAMINATE						
Bench Width	Screw Size	Quantity	Location	Screw Size	Quantity	Location
96" (2438,4mm)	#10 x 1-3/4" Long	8	Side Frame	#10 x 5/8" Long	11*	Stiffener
72" (1981,2mm)	#10 x 1-3/4" Long	8	Side Frame	#10 x 5/8" Long	9*	Stiffener
60" (1524,0mm)	#10 x 1-3/4" Long	8	Side Frame	#10 x 5/8" Long	7*	Stiffener
48" (1219,2mm)	#10 x 1-3/4" Long	8	Side Frame	#10 x 5/8" Long	7*	Stiffener
36" (914,4mm)	#10 x 1-3/4" Long	8	Side Frame	#10 x 5/8" Long	5*	Stiffener
30" (762,0mm)	#10 x 1-3/4" Long	8	Side Frame	#10 x 5/8" Long	2	Gusset Adapter
24" (609,6mm)	#10 x 1-3/4" Long	8	Side Frame	#10 x 5/8" Long	2	Gusset Adapter

SCREW CHART-MAPLE						
Bench Width	Screw Size	Quantity	Location	Screw Size	Quantity	Location
96" (2438,4mm)	#10 x 1-3/4" Long	6	Stiffener	#10 x 5/8" Long	-	-
72" (1981,2mm)	#10 x 1-3/4" Long	6	Stiffener	#10 x 5/8" Long	-	-
60" (1524,0mm)	#10 x 1-3/4" Long	6	Stiffener	#10 x 5/8" Long	-	-
48" (1219,2mm)	#10 x 1-3/4" Long	6	Stiffener	#10 x 5/8" Long	-	-
36" (914,4mm)	#10 x 1-3/4" Long	6	Stiffener	#10 x 5/8" Long	-	-
30" (762,0mm)	#10 x 1-3/4" Long	4	Side Frame	#10 x 5/8" Long	2	Gusset Adapter
24" (609,6mm)	#10 x 1-3/4" Long	4	Side Frame	#10 x 5/8" Long	2	Gusset Adapter

SCREW CHART-PHENOLIC						
Bench Width	Screw Size	Quantity	Location	Screw Size	Quantity	Location
96" (2438,4mm)	#10 x 1-1/2" Long	-	-	#10 x 5/8" Long	5*	Stiffener
72" (1981,2mm)	#10 x 1-1/2" Long	-	-	#10 x 5/8" Long	5*	Stiffener
60" (1524,0mm)	#10 x 1-1/2" Long	-	-	#10 x 5/8" Long	5*	Stiffener
48" (1219,2mm)	#10 x 1-1/2" Long	-	-	#10 x 5/8" Long	5*	Stiffener
36" (914,4mm)	#10 x 1-1/2" Long	-	-	#10 x 5/8" Long	5*	Stiffener
30" (762,0mm)	#10 x 1-1/2" Long	4	Side Frame	#10 x 5/8" Long	2	Gusset Adapter
24" (609,6mm)	#10 x 1-1/2" Long	4	Side Frame	#10 x 5/8" Long	2	Gusset Adapter

Note: Stiffener quantities with an Asterisk (\*) include 2 screws for Gusset Adapters.

6. Reassemble the Lower Side Frames to the Upper Side Frames using the carriage bolts, washers and nuts previously removed in step 2. Adjust the Lower Side Frames for the desired height of the TechBench™ and re-install the hardware as shown in figure 11a.

7. Install the 4" Back Panel to the lower hole patterns in the Lower Side Frames using six 1/4"-20 x 1/2" long hex head screws. See figure 11a.

8. Adjust each Glide Foot to meet a nominal dimension of 2-1/2". See figure 11b. While holding the Glide Foot with a 1/2" open end wrench, tighten the check nut with a 1" open end wrench.

9. With a minimum of two people, carefully turn the TechBench™ assembly right side up.

### LEVELING

1. Level the TechBench™ by adjusting the levelers as required.

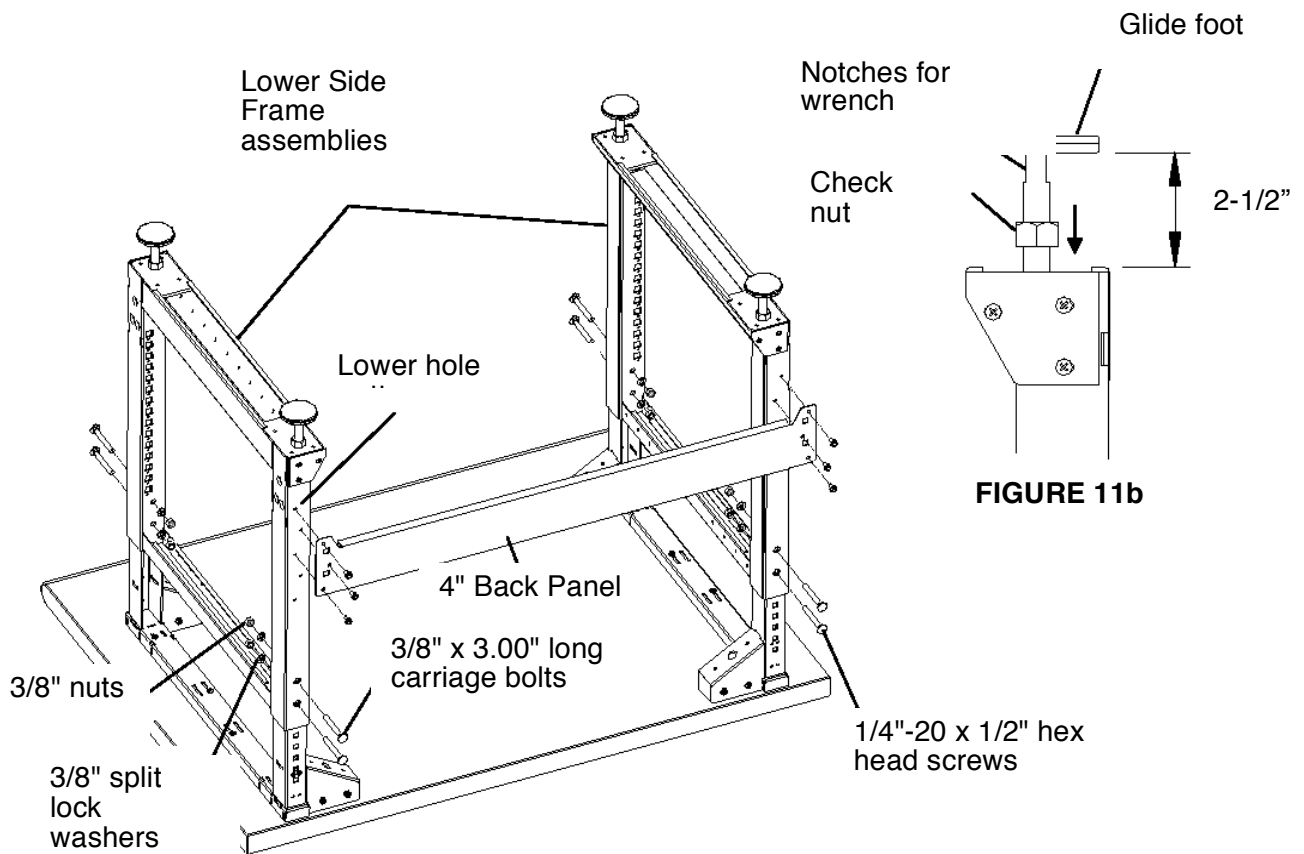
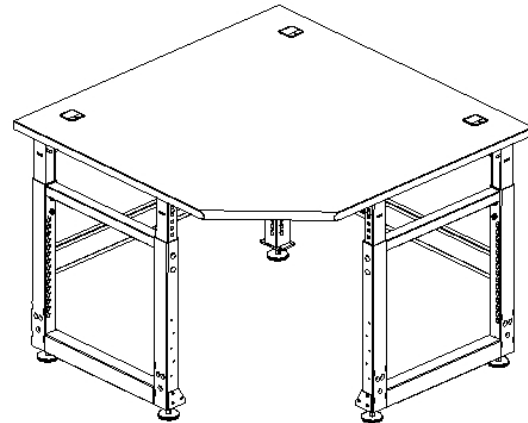

FIGURE 11a

FIGURE 11b

### CORNER BENCH ASSEMBLY

1. With two people, carefully unpack the Worksurface and place it finished side down on the empty carton or on a clean carpeted surface. **NOTE:** Pre-drilled mounting holes in underside of worksurface are visible.
2. Both sets of Upper and Lower Side Frames and the Upper and Lower Corner Post are pre-assembled at the factory. They must be unassembled before attaching them to the Worksurface. Remove the nuts, lock washers and carriage bolts and separate the Upper and Lower Side Frames and Upper and Lower Corner Post. See figure 12a and 12b. **NOTE: Do not discard this hardware.** It will be used in step 19.



Corner  
TechBench™

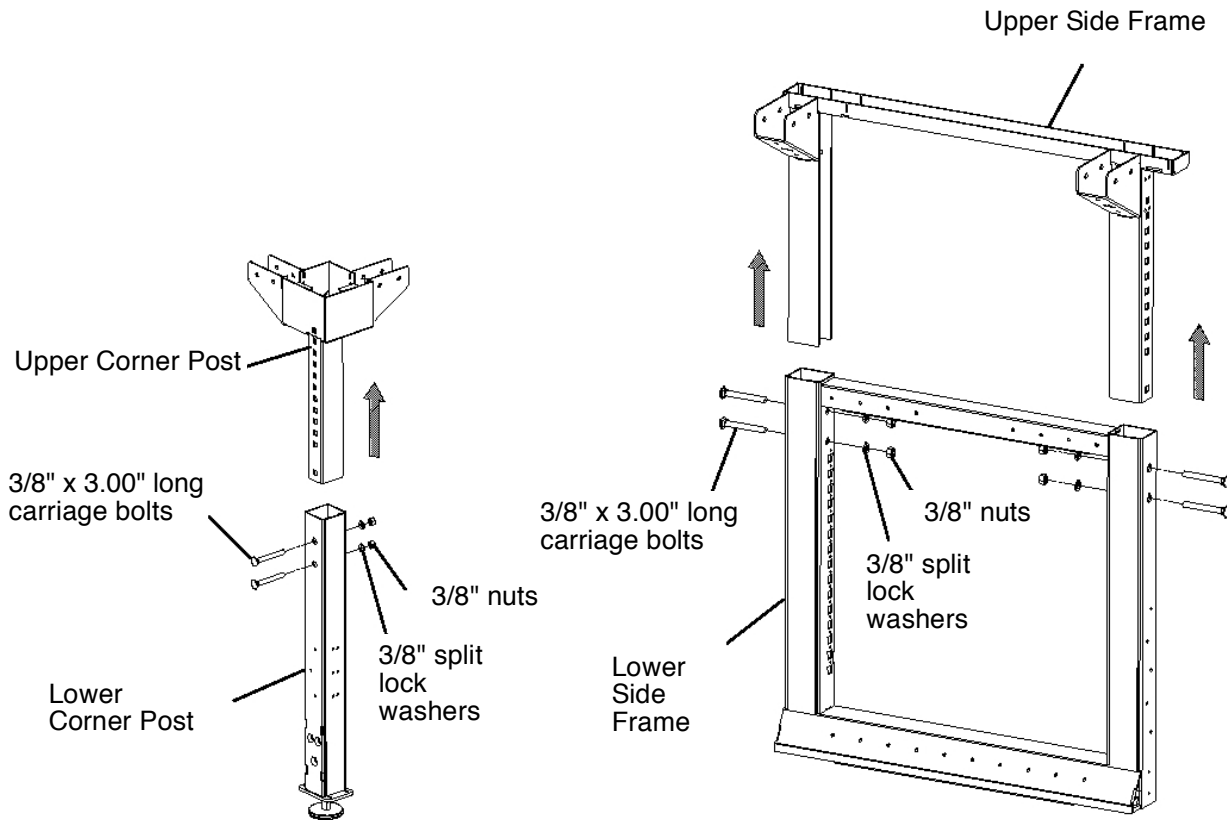

FIGURE  
12b

FIGURE  
12a

3. Assemble the Stiffeners to the Upper Side Frames and Upper Corner Post as shown in figures 13. Slide the "tongue" at the end of the Stiffeners into the slots on the top of the Upper Side Frames. See Detail A.

Align the holes in the tongue with the holes in the top of the frame and secure using two 1/4"-20 x 1/2" long hex head screws. Secure the gusset to the Stiffener using four 1/4"- 20 x 1/2" long hex head screws.

Slide the "tongue" onto the top of the Upper Corner Post and align the holes in the tongue with the holes in the top of the post and secure using two 1/4"-20 x 1/2" long hex head screws. See Detail B. Secure the gusset to the Stiffener using four 1/4"-20 x 1/2" long hex head screws.

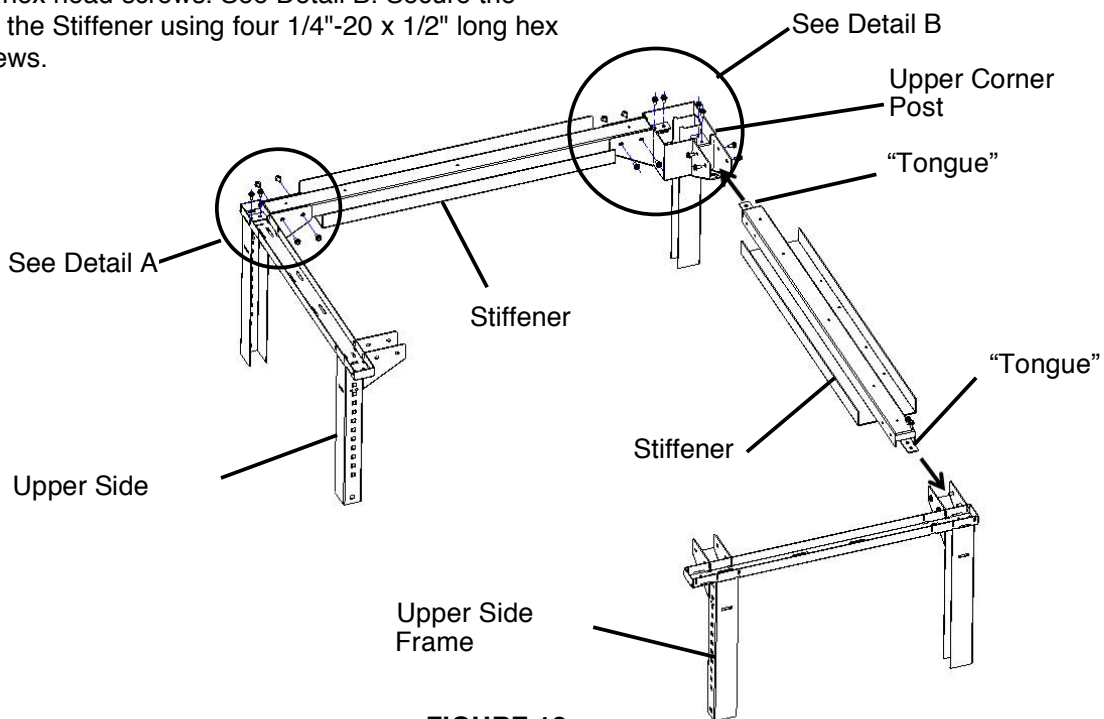

**FIGURE 13**

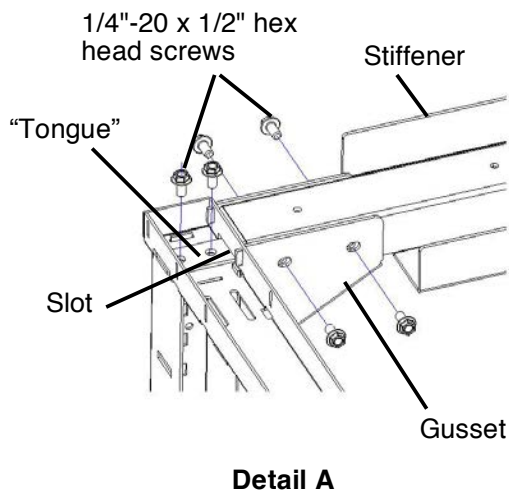

**Detail A**

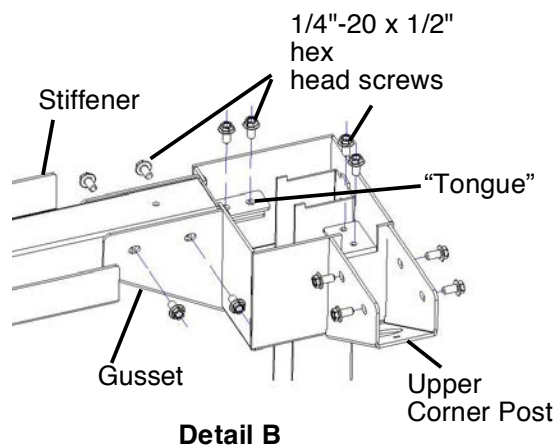

**Detail B**

4. Assemble two Gusset Adapters to the Worksurface using two #10 x 5/8" Phillips head screws. See figure 14.
5. Turn the Upper Frame assembly over and position it on the worksurface as shown in figure 15.

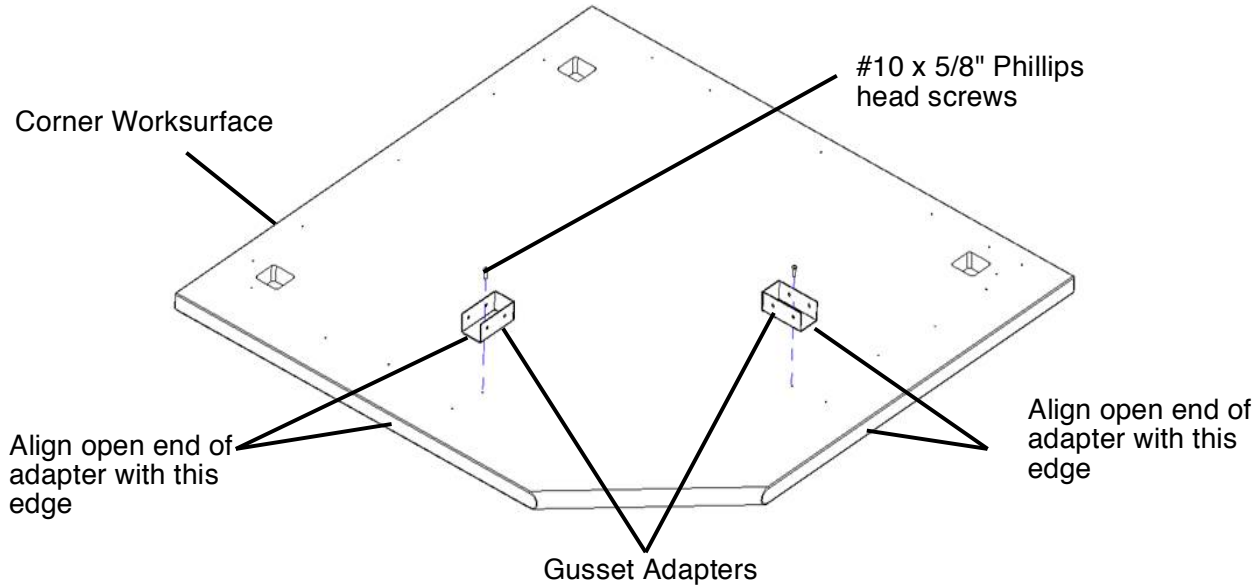

**FIGURE 14**

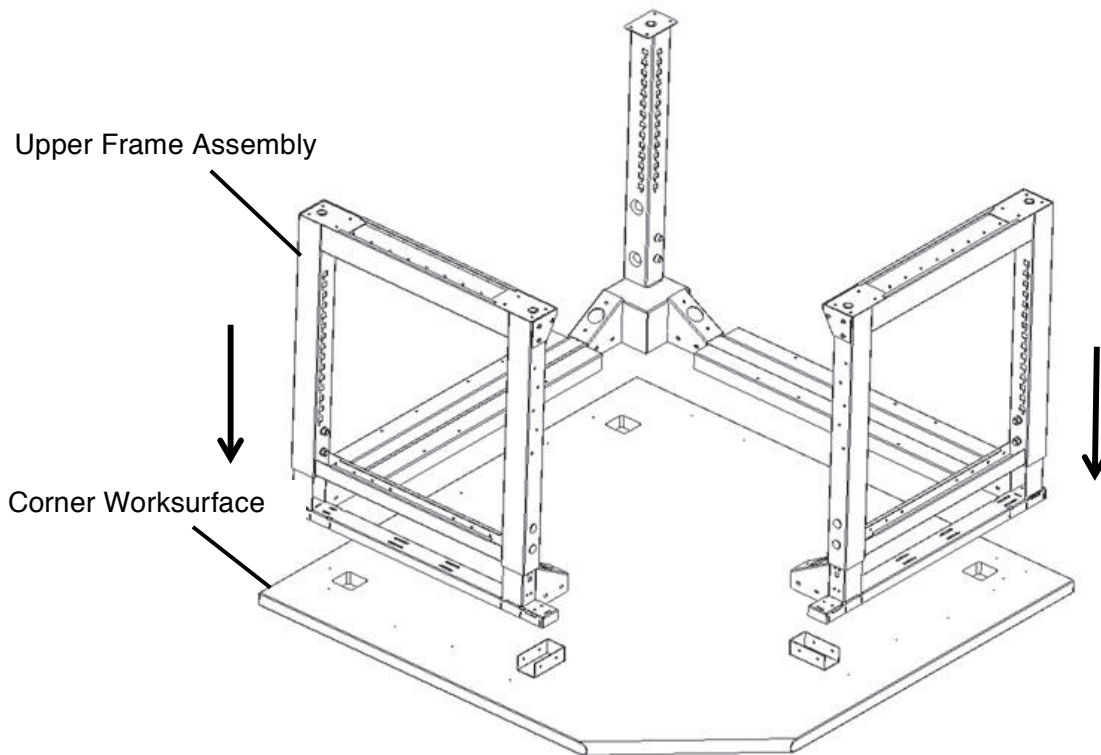
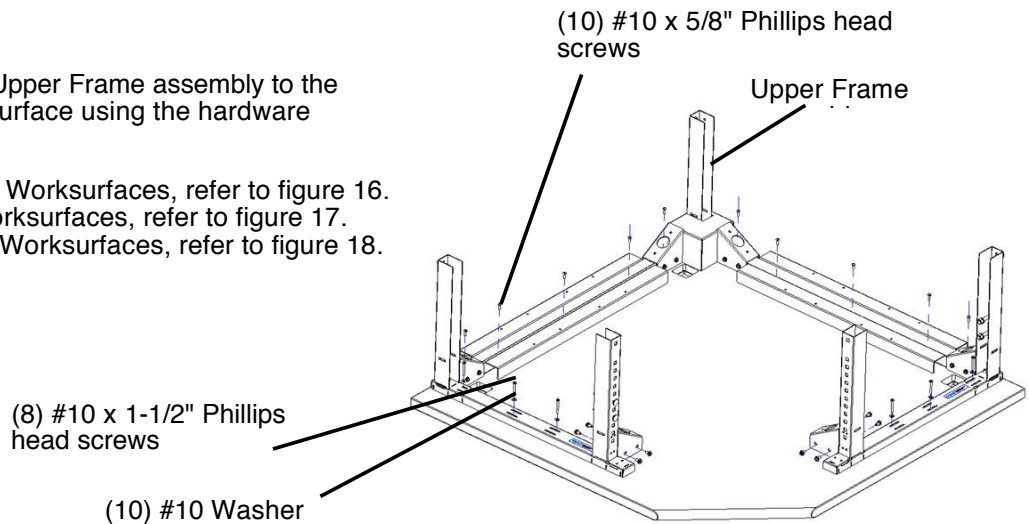

**FIGURE 15**



6. Attach the Upper Frame assembly to the Corner Worksurface using the hardware provided.

For **Laminate** Worksurfaces, refer to figure 16.  
For **Maple** Worksurfaces, refer to figure 17.  
For **Phenolic** Worksurfaces, refer to figure 18.



**Figure 16**  
*Laminate Worksurface*

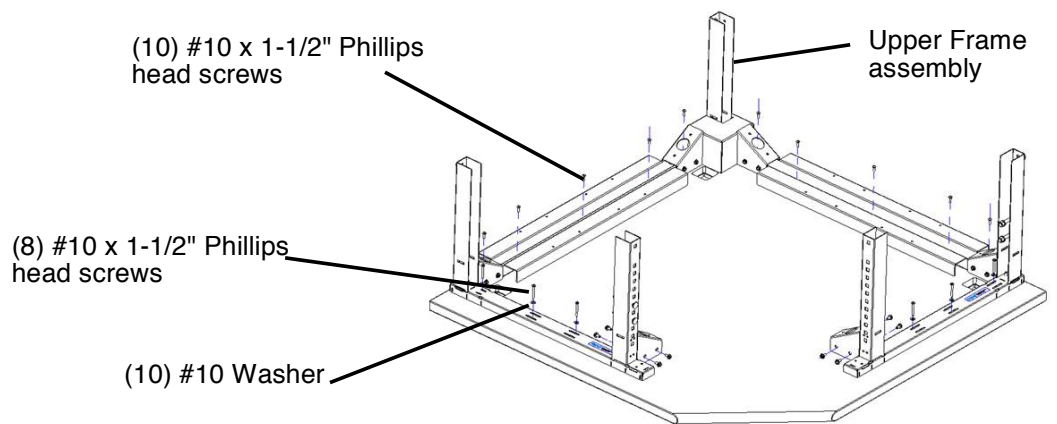

**Figure 17**  
*Maple Worksurface*

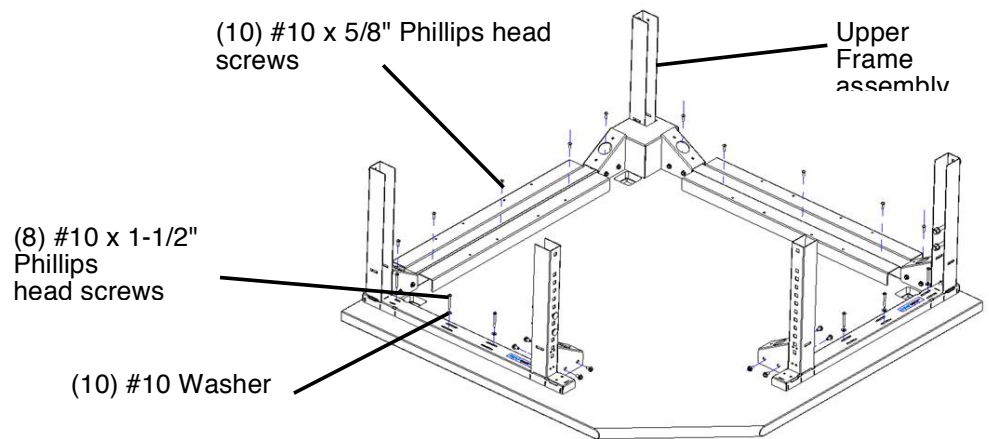

**Figure 18**  
*Phenolic Worksurface*

7. Reassemble the Lower Side Frames and Upper Corner Post using the carriage bolts, washers and nuts previously removed in step 2. Adjust the Lower Side Frames and Lower Corner Post for the desired height of the TechBench™ and re-install the hardware as shown in figure 19a. NOTE: Connectors are installed in the same manner as the Linear benches with the exception of the Corner Connector. See figure 20.

8. Install the 4" Back Panel to the lower hole patterns in the Lower Side Frames using six 1/4"-20 x 1/2" long hex head screws. See figure 19a.

9. Adjust each Glide Foot to meet a nominal dimension of 2-1/2". See figure 19b. While holding the Glide Foot with a 1/2" open end wrench, tighten the check nut with a 1" open end wrench.

10. With a minimum of two people, carefully turn the TechBench™ assembly right side up.

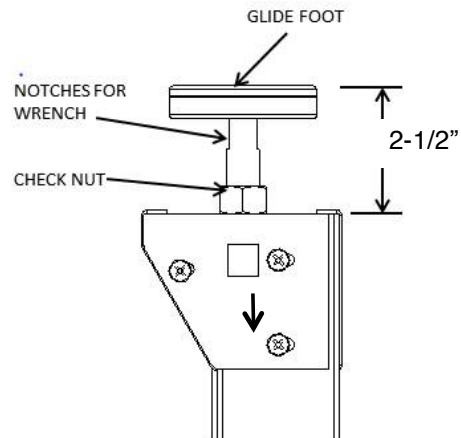

FIGURE 19b

### LEVELING

1. Level the TechBench by adjusting the levelers as required.

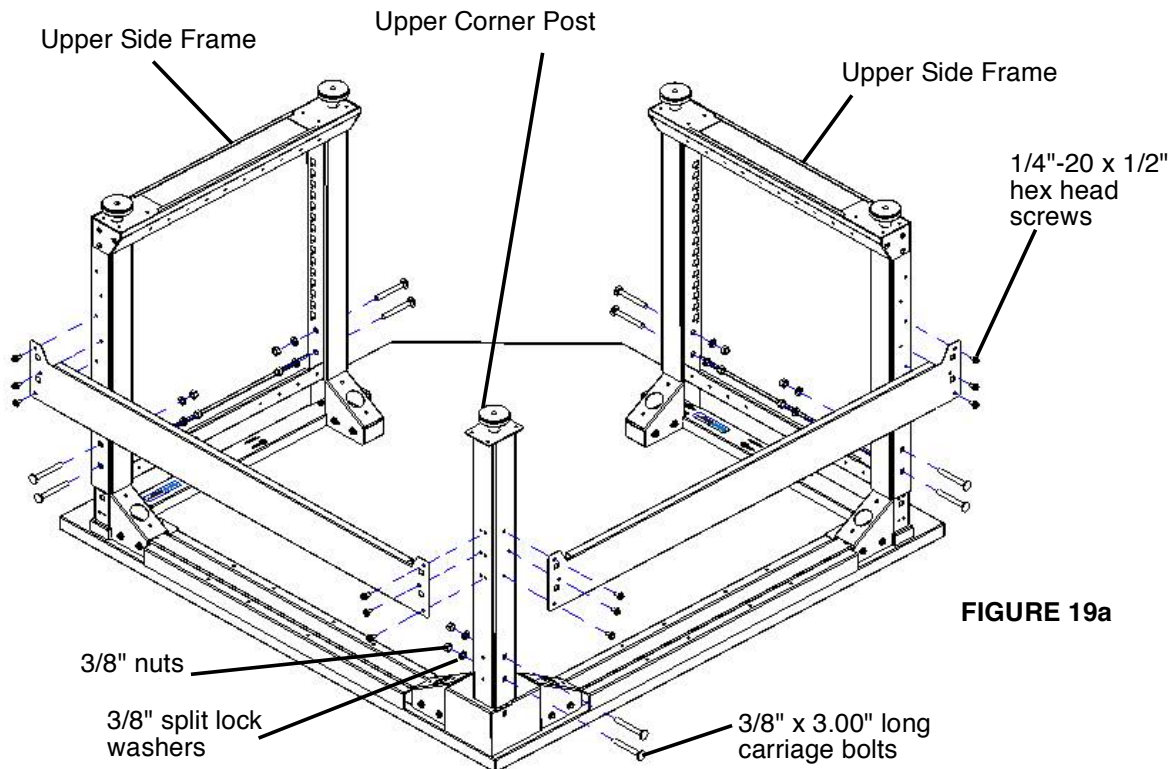
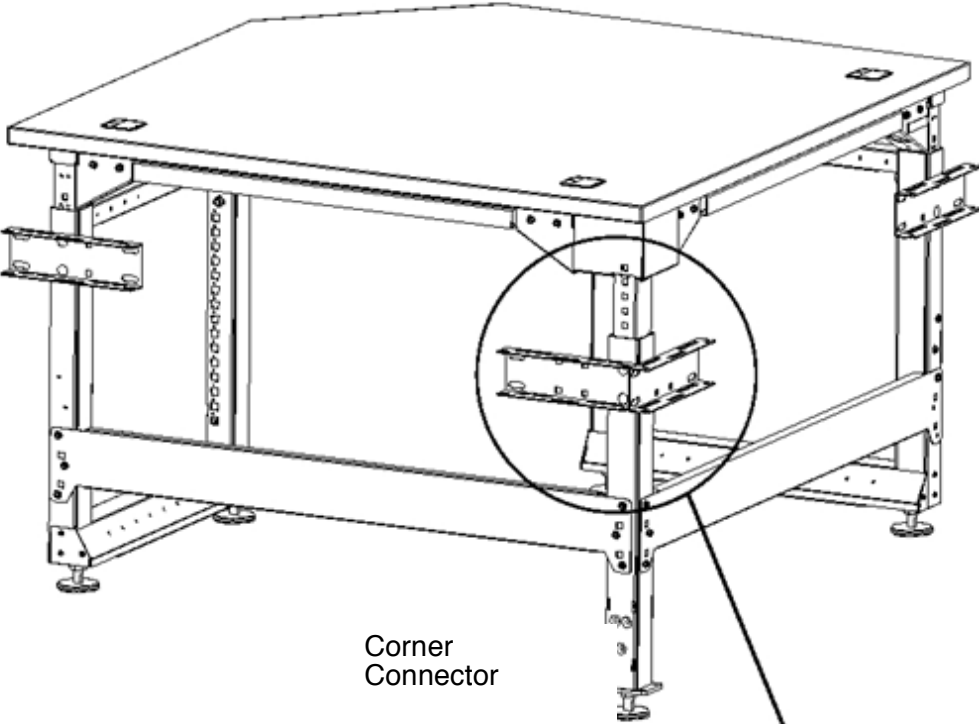
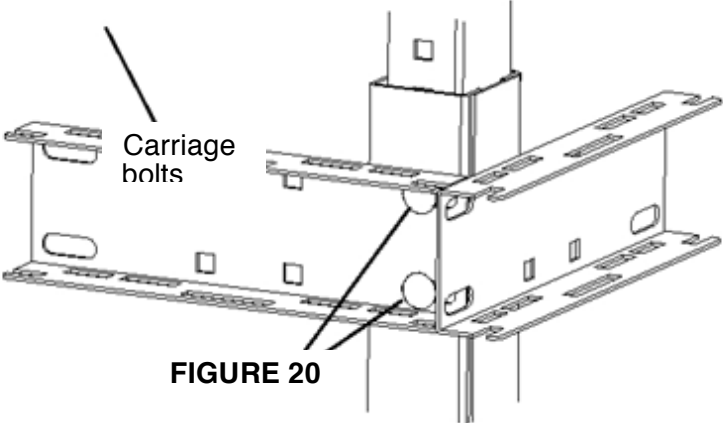

FIGURE 19a



Corner  
Connector



Carriage  
bolts

**FIGURE 20**



**Eaton**  
1000 Eaton Boulevard  
Cleveland, OH 44122  
United States  
Eaton.com

© 2018 Eaton  
All Rights Reserved  
Printed in USA  
Publication No. IB210002EN  
May 2018

**Eaton**  
160 Gold Star Boulevard  
Worcester, MA 01606  
United States  
800-225-7348  
508-852-4300  
Eaton.com/compass

Eaton is a registered trademark.

\*All trademarks are property  
of their respective owners.

Follow us on social media to get the  
latest product and support information.

