

TechBench™ Caster

Tools required

- (1) ½" Open end wrench (not supplied)
- (1) ¼" Allen wrench (not supplied)

IMPORTANT: A full shelf or foot rest must be installed on the TechBench if casters are to be used.

1. Using a ½" open end wrench, remove the Glide Feet from the TechBench. Place the wrench on the "flats" located on the threaded shaft and back the Glide Foot out. See figure 1a and 1b.

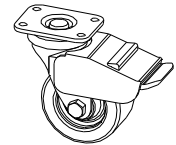
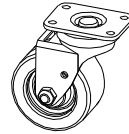

TechBench casters

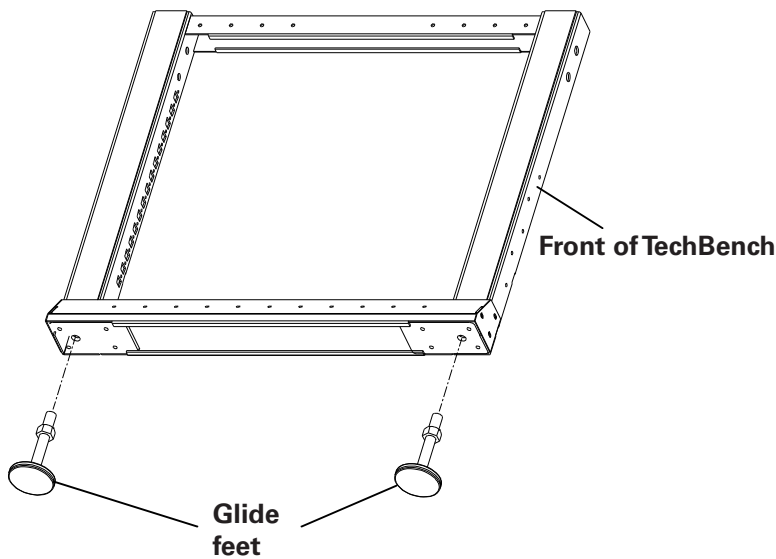

Figure 1a

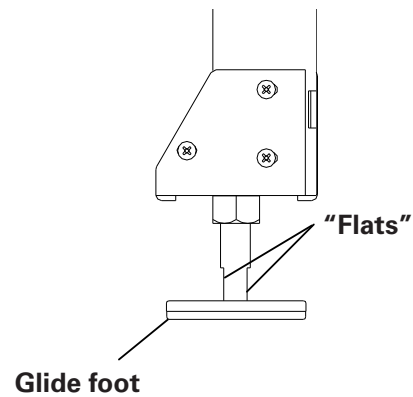

Figure 1b

2. Install the **Locking** Casters on the front of the TechBench using the 5/16" x 3/4" long socket head cap screws and washers provided. See figure 2.
3. Install the **Non-locking** Casters on the rear of the TechBench using the 5/16" x 3/4" long socket head cap screws and washers provided. See figure 2.

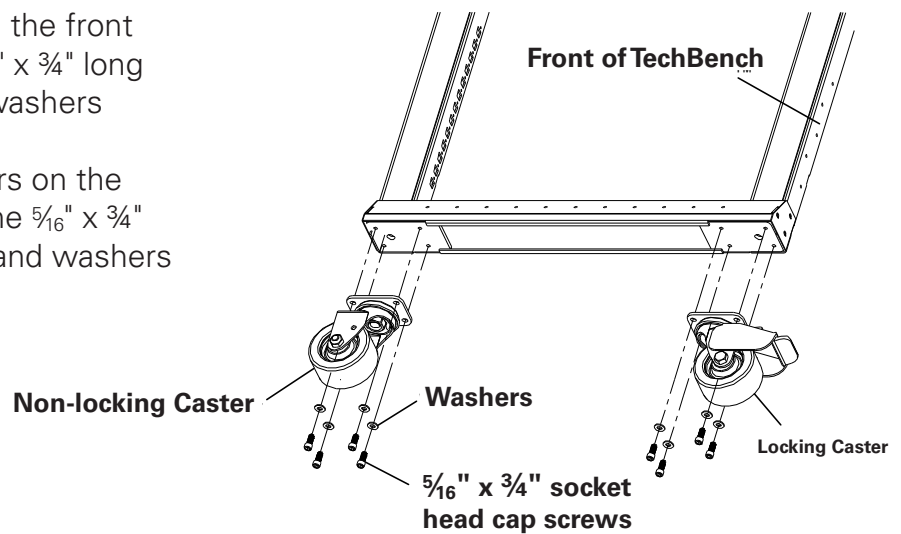

Figure 2

Eaton
1000 Eaton Boulevard
Cleveland, OH 44122
United States
Eaton.com

© 2018 Eaton
All Rights Reserved
Printed in USA
Publication No. 1L210006EN
March 2018

Eaton is a registered trademark.

All trademarks are property of their respective owners.