

Cable chain kit installation

These instructions are specific to Lift PEC48482

Kit parts

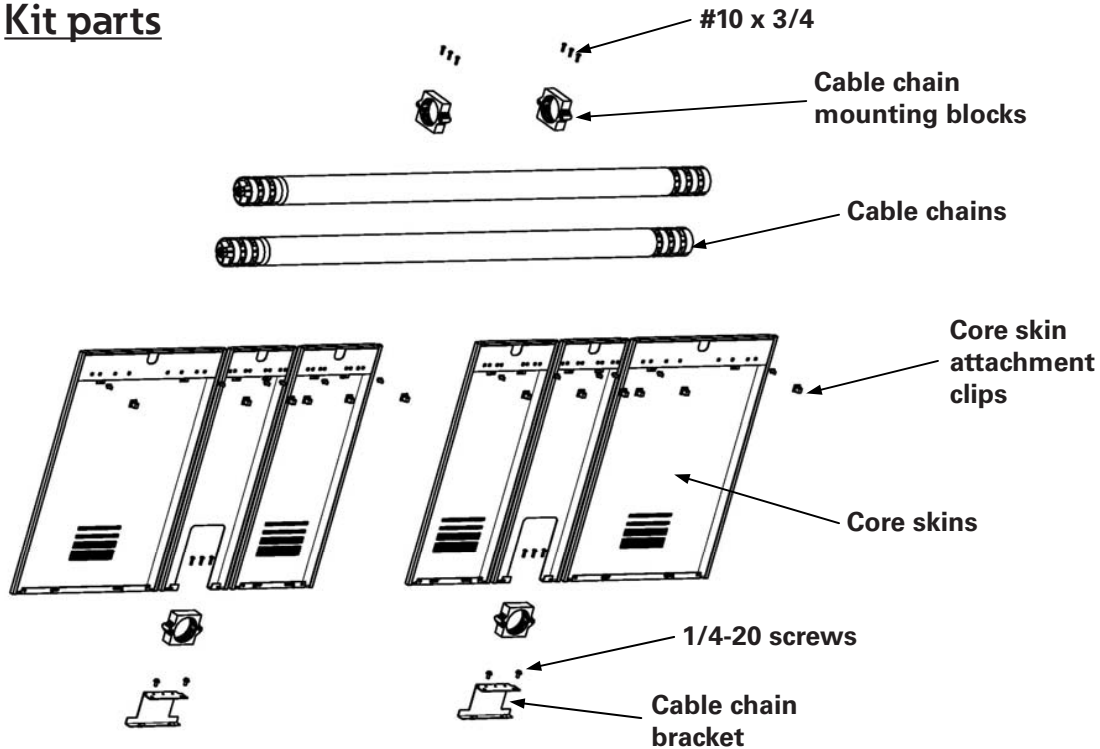

1. Remove existing skins from user-facing side of cores. They will not be re-used.
2. Attach brackets to cores using 1/4-20 self-tapping screws in locations shown.
3. Remove hitch pin and open cable chain mounting blocks. Drill thru plastic mounting block housing (3 holes). Secure to bracket with (3) #10 x 3/4 sheet metal screws.
4. Clamp cable chain into mounting block.

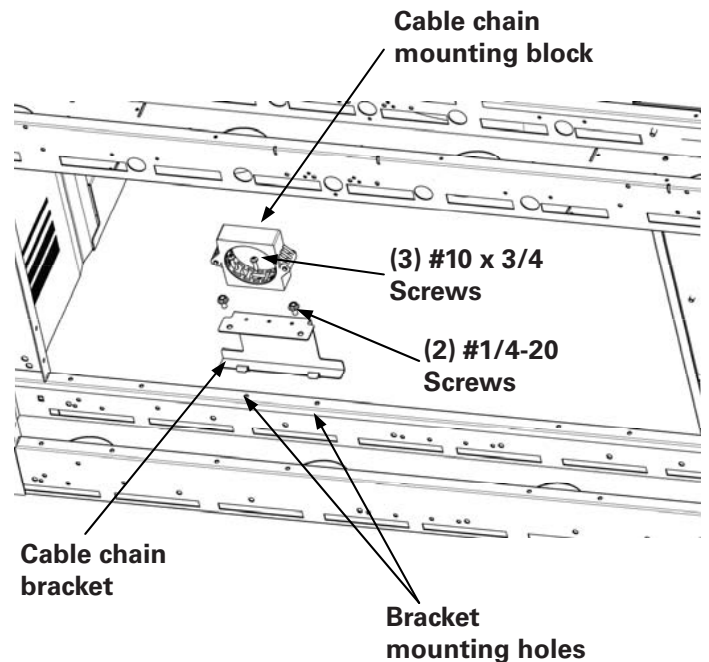

Powering Business Worldwide

- Place new core skins in locations as shown and attach to cores. Measurements are approximate.

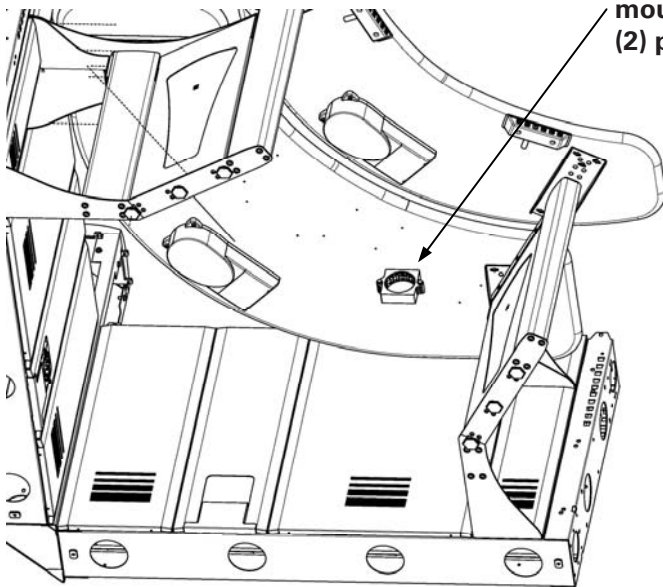
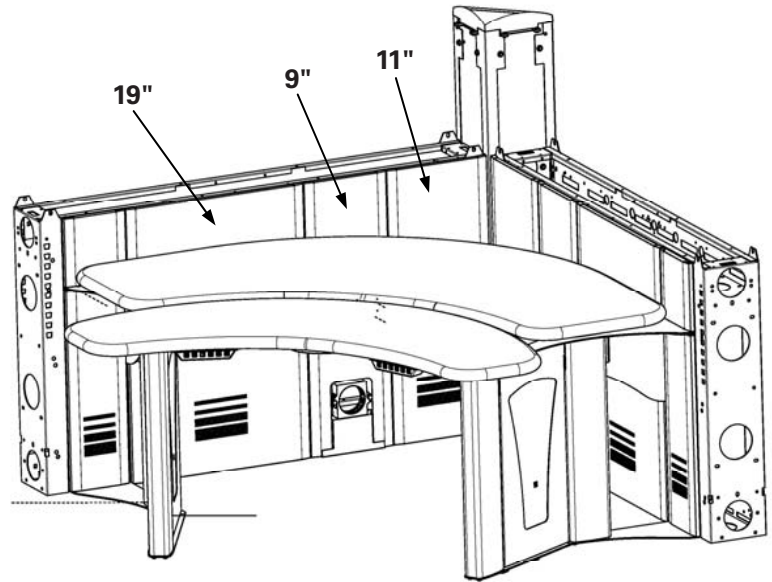

Cable chain mounting block (2) places

- Determine an appropriate location to attach the (2) Cable Chain Mount blocks to bottom of the Main Worksurface. Cable chains must be routed in such a way to avoid being damaged when the Lift is actuated.

NOTE: There are no pre-drilled pilot holes for the mounting blocks.

- Remove hitch pin and open cable chain mounting blocks. Drill thru plastic mounting block housing (3 holes) and secure to underside of main worksurface using (3) #10 x $\frac{3}{4}$ " screws.
- Clamp Cable Chain into Mounting Block and replace hitch pin.

Eaton
1000 Eaton Boulevard
Cleveland, OH 44122
United States
Eaton.com

© 2018 Eaton
All Rights Reserved
Printed in USA
Publication No. IL210003EN
March 2018

Eaton is a registered trademark.

All trademarks are property of their respective owners.