

# CPU Docker Rack Mount Conversion

## Item Numbers

17601204, PCPRKIT20, PCPRKIT28

## Tools Required

- Phillips head screwdriver (not supplied)
1. Remove the Roll-Out Tray and slides from the Docker as shown in figure 1.
  2. Install upper channels on both sides of Docker with #89957 screws as shown in figure 1.
  3. Loosely install the #88114 screws, #87858 lock washers and #87382 T-handles to the four Rack Mount Rails as shown in figure 2.
  4. Install the Rack Mount Rails inside the Docker as shown in figure 3. Slide the screws behind the slots and move each rail to their appropriate location and tighten the T-handles.

Note; Item 17601204  
Does Not Require  
the upper channels

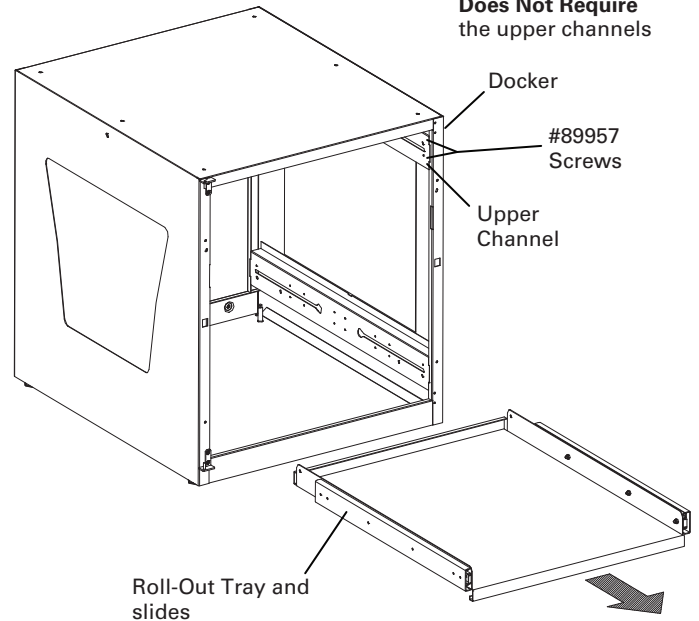

Figure 1

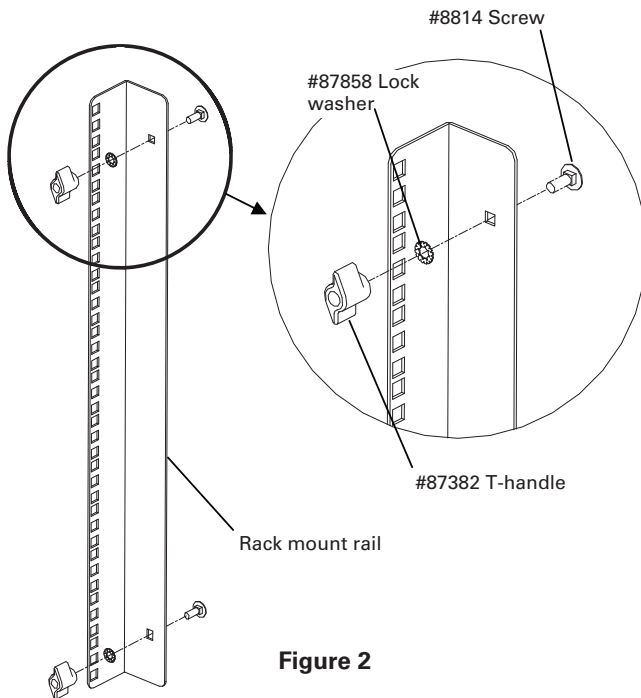

Figure 2

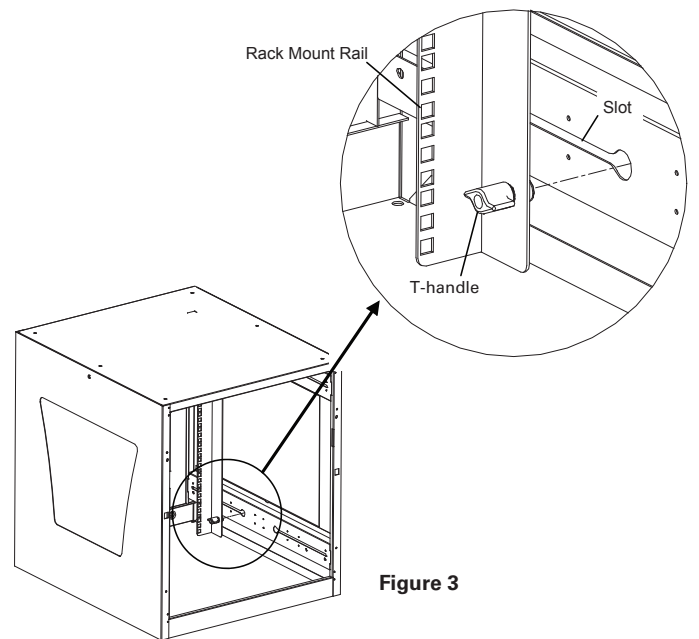

Figure 3

Eaton  
1000 Eaton Boulevard  
Cleveland, OH 44122  
United States  
Eaton.com

© 2018 Eaton  
All Rights Reserved  
Printed in USA  
Publication No. IL211004EN  
April 2018