

OnGuard command console installation manual

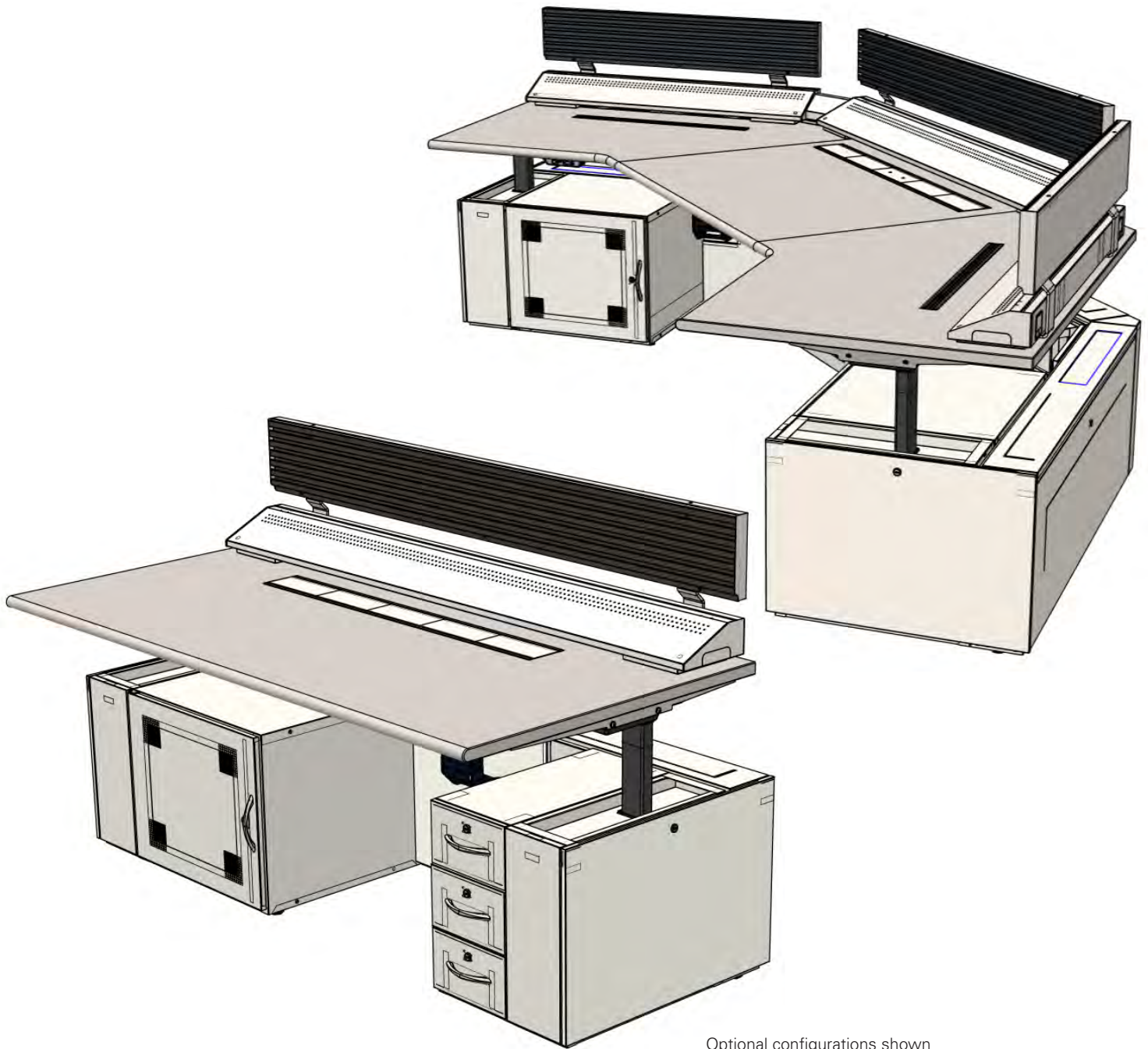

Optional configurations shown



Powering Business Worldwide

Table of contents

I. GENERAL INFORMATION	
About this guide	2
Contact information	2
Before you begin	3
Safety warnings and precautions	3-4
II. PREPARING TO ASSEMBLE THE CONSOLE	
Console components and options	5-10
Tools required	11
Personal protective equipment recommended	11
Assembly hardware	12
III. ASSEMBLING THE CONSOLE	
Assembling the corner console	13-15
Install and connect the lift motor components	16-18
Initialize the lift motor systems	18
Install the worksurface	19-21
Install the TechCurb™	22-23
Install the rear corner covers	24
IV. ACCESSORIES	
TechTrack™ components	25
Monitor poles	26
Personal environment system	27
Task light bracket	28
V. CONSOLE ELECTRICAL CONNECTIONS	
Grounding and bonding the console	29
Plugging the console in	29
VI. SETTING UP AND USING THE CONSOLE	
Cabling the console	30
Operating the height adjustable worksurface	30
Using the personal environment system	31
VII. SYSTEM LAYOUT AND CONNECTORS	
OnGuard system layouts	32
Prepare consoles for system layout	33
Assemble consoles with front connector	34
Assemble consoles with front tear drop or peninsula connector	35
Assemble consoles with 45, 90 degree and linear connectors	36
Assemble rear connector worksurface and end peninsula to end of console	37
Assemble rack mount tower to layout end and inbetween consoles	38
Assemble multiple consoles together	39
VIII. USER MAINTENANCE INSTRUCTIONS	
Care and cleaning	40

About this guide

This document is intended to help provide direction on the unpacking and basic assembly of Eaton's OnGuard Command Console System and it's configurable accessories. Additional copies of this manual are available at: Eaton.com/onguard

Intended audience

This document is intended for personnel experienced at installing console equipment in a control center facility.

Technical support

If you encounter any problems with this installation, send an email and detailed description of the problem, as well as contact information, to Technical Support at: ToSupportESWorcesterMA@eaton.com

Document history

The following table shows this document's revision history:

February, 2017	First Publication – Pub No. IB210002EN
November, 2019	Second Publication – Pub No. IB210003EN

Sales representative and contact information

Contact your Eaton Sales representative using one of the methods below:

Phone Call us toll free at 800-225-7348 (US Only)
or 508-852-4300

Mail Eaton
160 Gold Star Boulevard
Worcester, MA 01606

Email InfoESWorcesterMA@Eaton.com

Web Visit us at www.eaton.com/onguard and click on "Contact Us." Simply complete and submit the form as directed on our website.

DISCLAIMER OF WARRANTIES AND LIMITATION OF LIABILITY

The information, recommendations, descriptions and safety notations in this document are based on Eaton Corporation's ("Eaton") experience and judgment and may not cover all contingencies. If further information is required, an Eaton sales office should be consulted. Sale of the product shown in this literature is subject to the terms and conditions outlined in appropriate Eaton selling policies or other contractual agreement between Eaton and the purchaser.

THERE ARE NO UNDERSTANDINGS, AGREEMENTS, WARRANTIES, EXPRESSED OR IMPLIED, INCLUDING WARRANTIES OF FITNESS FOR A PARTICULAR PURPOSE OR MERCHANTABILITY, OTHER THAN THOSE SPECIFICALLY SET OUT IN ANY EXISTING CONTRACT BETWEEN THE PARTIES. ANY SUCH CONTRACT STATES THE ENTIRE OBLIGATION OF EATON. THE CONTENTS OF THIS DOCUMENT SHALL NOT BECOME PART OF OR MODIFY ANY CONTRACT BETWEEN THE PARTIES.

In no event will Eaton be responsible to the purchaser or user in contract, in tort (including negligence), strict liability or otherwise for any special, indirect, incidental or consequential damage or loss whatsoever, including but not limited to damage or loss of use of equipment, plant or power system, cost of capital, loss of power, additional expenses in the use of existing power facilities, or claims against the purchaser or user by its customers resulting from the use of the information, recommendations and descriptions contained herein. The information contained in this manual is subject to change without notice.

Before you begin

Before installing the OnGuard Command Console, it is recommended that you do the following:

- Read and understand the instruction herein before attempting to unpack, assemble, operate or service the OnGuard Command Console.
- Follow all information that is found on safety labels on the product and packaging.
- Familiarize yourself with the various console components described within this manual.
- The use of personal protective equipment such as safety glasses, work gloves and steel toed shoes are recommended during the unpacking and set-up of the console.
- Read, understand and follow the guidelines and limitations herein for loading your console.
- Familiarize yourself with the warning symbols that appear throughout this manual.



DANGER indicates a hazardous situation which, if not avoided, will result in death or serious injury.



CAUTION indicates a hazardous situation which, if not avoided, could result in minor or moderate injury.



WARNING indicates a hazardous situation which, if not avoided, could result in death or serious injury.



NOTICE is used to address practices not related to physical injury. Notice points out something of special interest to the reader in direct context or relationship to the immediate topic or step being performed.

Important safety instructions

DANGER Read all instructions before assembling and using this furnishing - Save these instructions



DANGER – To reduce the risk of electric shock: This console includes two power cords. Always fully unplug this console from the electrical outlets before cleaning, testing, repairing or moving the console.



1. This console is for commercial use only.
2. Unplug from outlet before putting on or taking off parts. NOTE: This console includes two power cords.
3. Close supervision is necessary when this furnishing is used by, or near children, invalids, or disabled persons.
4. Use this furnishing only for its intended use as described in these instructions. Do not use attachments not recommended by the manufacturer.
5. Never operate this furnishing if it has a damaged cord or plug, if it is not working properly, if it has been dropped or damaged, or has become wet. Return the furnishing to a service center for examination and repair.
6. Keep the cord(s) away from heated surfaces.
7. Never operate the furnishing with the air openings blocked. Keep the air openings free of lint, hair, and the like.
8. Never drop or insert any object into any opening.
9. Do not use outdoors.
10. To disconnect, turn all controls to the off position, then remove plugs from outlets.
11. **WARNING:** Risk of Electric Shock – Connect this furnishing to properly grounded outlets only. See grounding instructions.
12. To reduce risk of electrical shock, this furnishing has polarized plugs (one blade wider than the other). These plugs will fit into polarized outlets only one way. If a plug does not fit fully into the outlet, reverse the plug. If it still does not fit, contact a qualified electrician to install the proper outlet. Do not change the plug in any way.



13. DO NOT, UNDER ANY CIRCUMSTANCE, PLACE A BODY PART IN THE PATH OF THE WORKSURFACE WHILE IT IS BEING LOWERED.

DO NOT PLACE ANY OBJECT ON TOP OF THE CONSOLE'S SUPPORT BASE THAT COULD INTERFERE WITH THE TRAVEL OF THE WORKSURFACE.

This console has an electrically driven adjustable worksurface. In its lowest position, the worksurface is very close to the support base structure. The console's lift motors have sensors that will detect an obstruction when moving downward. When an obstruction is sensed, the worksurface will automatically begin to raise.

14. Installation and assembly must be performed by qualified personnel.
15. Ensure that the floor is able to withstand the weight of the console when fully loaded.

16. Ensure the console is plumb and level for proper operation. Route all power cords and cabling as instructed, away from any possible pinch points or moving parts.
17. To reduce risk of personal injury and product damage, always ensure a sufficient amount of personnel are present when unpacking, moving and assembling the console system.

Failure to adhere to these warnings may result in serious injury or property damage.



Electrical ratings

Lift motor controller: 90 – 240V AC, 48Hz – 63Hz (universal)

Console capacities

Dynamic load capacity of height adjustable lift motors: 1,000 lb. (4 lift), 750 lbs. (3 lift), 500 lbs. (2 lift)

Work surface capacity: 520 lbs. (4 lift), 375 lbs. (3 lift), 250 lbs. (2 lift)

Base cabinet flush drawer capacity: Large drawer: 50 lbs.
Small drawer: 40 lbs.

Base cabinet roll-out shelf capacity: 60 lbs.

Monitor pole capacity: 60 lbs. each

Power distribution strips: 20 amps 120V AC (2 circuits)



Do not apply loads that exceed the capacity of the console.

The applied load includes any items installed or placed onto the console worksurface or into the base cabinet compartments after receipt of the console from the carrier. Applied loads include (but are not limited to) monitor poles, electronic equipment, power distribution units, cabling, Personal Environment System, and personal items.



TO ENSURE ADEQUATE AIR FLOW TO COOL STORED ELECTRONIC DEVICES, DO NOT LOCATE THE BACK OF THE CONSOLE CLOSER THAN 3" TO ANY WALL, OR SIMILAR OBSTRUCTION. DO NOT PLACE ANY OBSTRUCTION NEAR ANY COOLING PERFORATIONS.

EACH OF THE THREE BASE CABINETS (LH, RH AND CENTER) HAS A 650 WATT MAXIMUM COOLING CAPACITY. WHEN ADEQUATE AIR FLOW IS PROVIDED, THE TEMPERATURE RISE WITHIN THE COMPARTMENT WILL BE NO GREATER THAN 25 DEGREES (F) (14° C). are not limited to) monitor poles, electronic equipment, power distribution units, cabling, Personal Environment System, and personal items.



Available OnGuard modular elements

Corner workstation module configuration sizes

LIFT QTY	1-Corner Size	2-Flank width (RH - LH)	3- Center base width	4-Worksurface width (ref.)
4	102"	49"	68"	142"
4	96"	49"	59"	133"
4	84"	49"	42"	116"
4	72"	37"	42"	100"
3	66"	37"	34"	91"
3	60"	37"	25"	82"

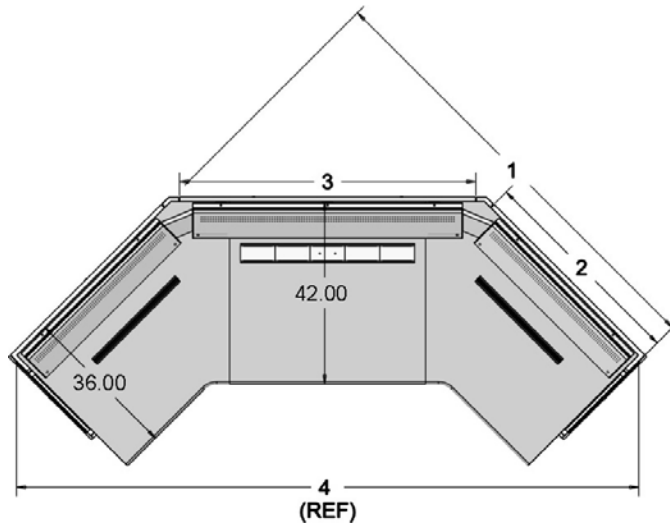

Linear workstation module configuration sizes

LIFT QTY	1-Linear Width	2- Worksurface width	3-Overall Depth	4-Worksurface Depth
2	72"	70"	37"	36"
2	60"	58"	37"	36"
2	48"	46"	37"	36"

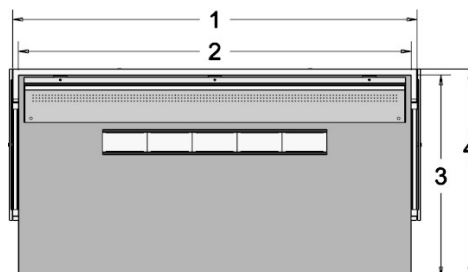

OnGuard command corner console components and options

Workstation configuration options

- **Basic (without storage)**

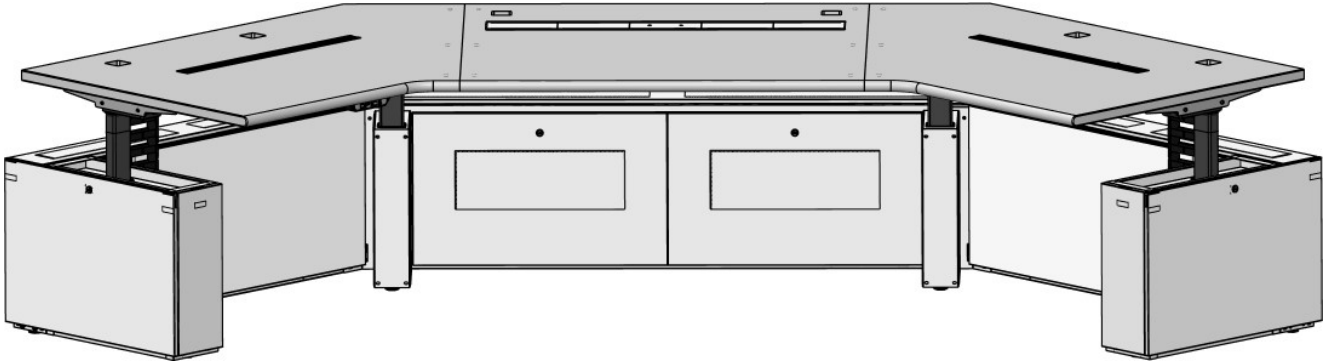

- **Enhanced storage**

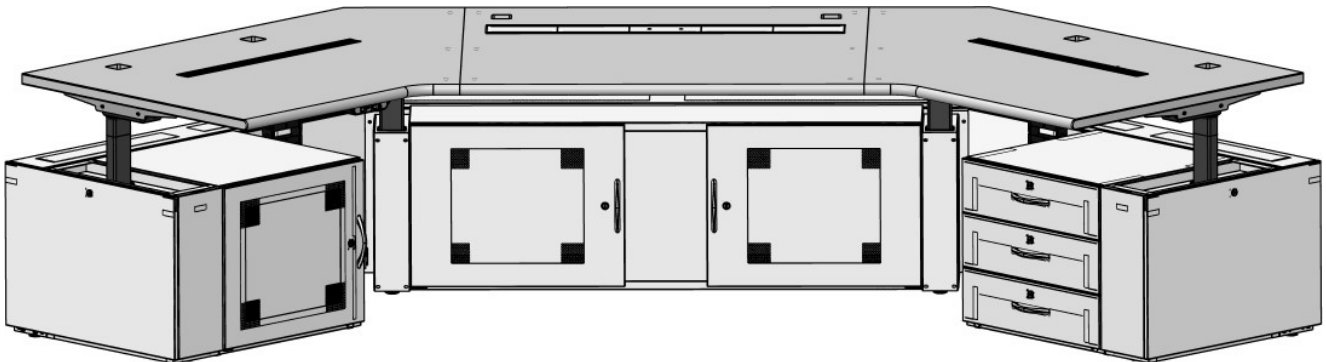

- **Integrated environmental control unit**

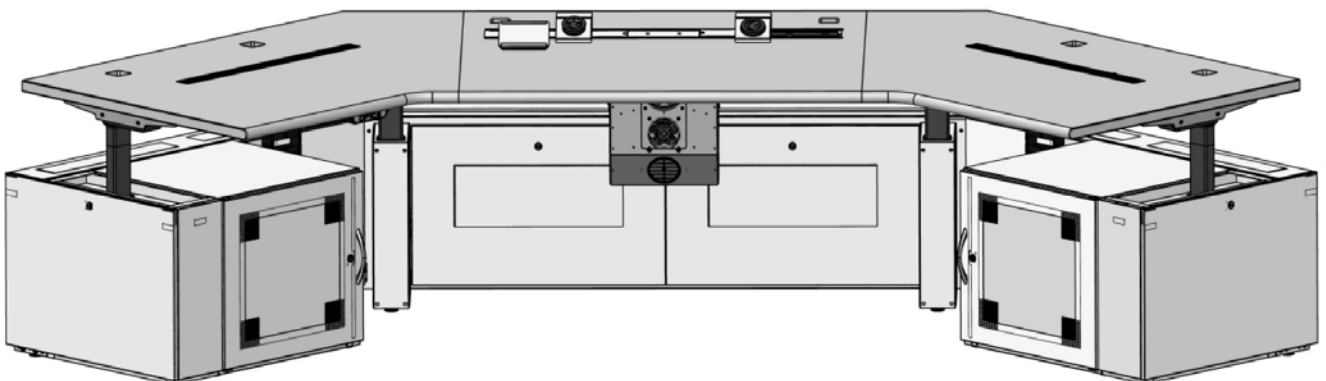

OnGuard command corner console components and options

- A. Motorized Lift / Stationary support
- B. Main worksurface
- C. Techtrack
- D. Monitor pole track
- E. Optional Techcurb
- F. Optional Slatwall
- G. Optional environmental control unit
- H. Side panel (powdered steel or laminate)

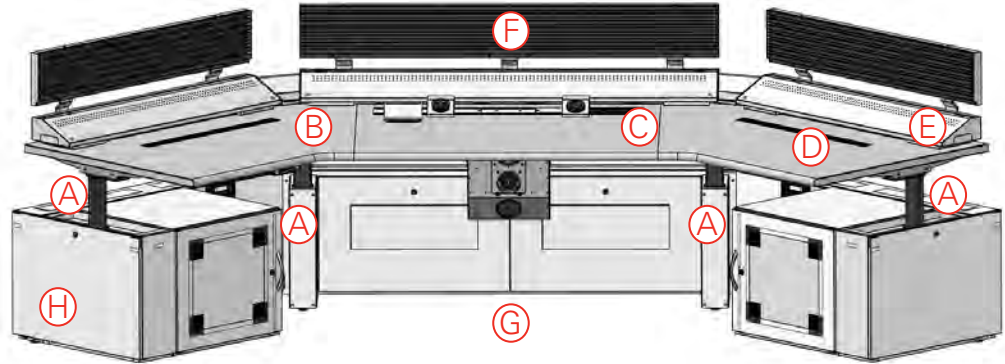

- I. Left hand base core
- J. Right hand base core
- K. Center base core
- L. Storage module
- M. Left hand worksurface support
- N. Right hand worksurface support
- O. Center rear worksurface support

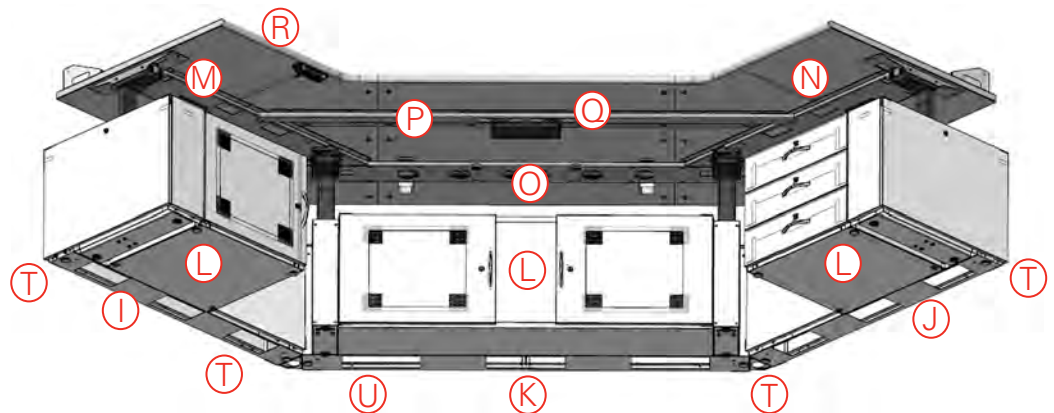

- P. Center front worksurface support
- Q. Lift control box
- R. Lift control pad
- S. Cable chain
- T. Leveling feet
- U. Bottom cable access
- V. Rear panel (powdered steel or laminate)

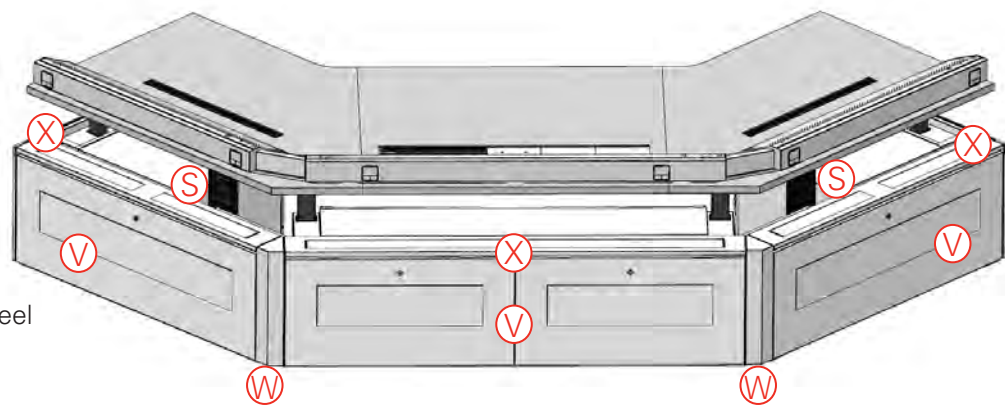

- W. Rear corner cover
- X. Rear core flip up cover

OnGuard command linear console components and options

Workstation configuration options

- **Basic (without storage)**

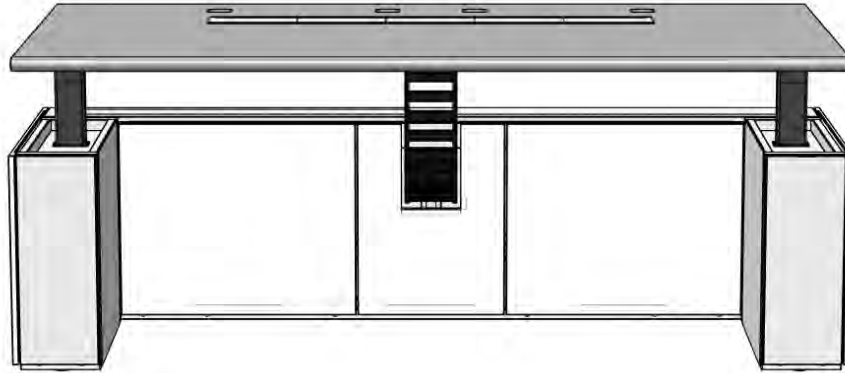

- **Enhanced storage**

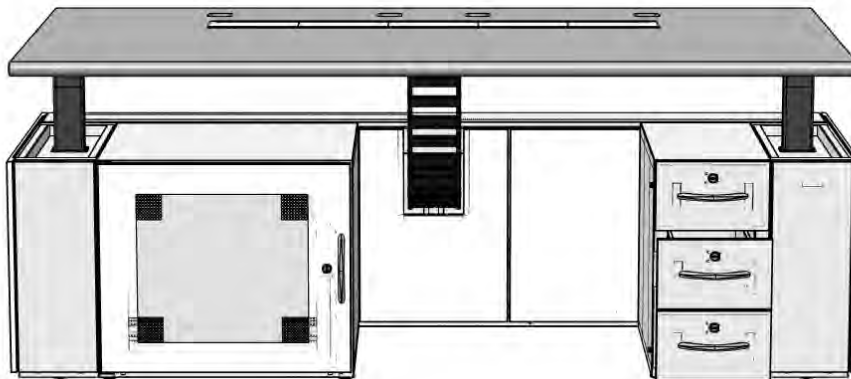

- **Integrated environmental control unit**

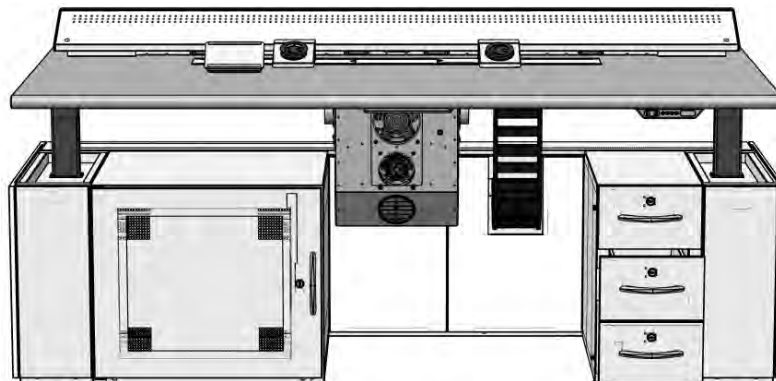

OnGuard command linear console components and options

- A. Motorized Lift / Stationary support
- B. Main worksurface
- C. Techtrack
- D. Optional Techcurb
- E. Optional Slatwall
- F. Optional environmental control unit
- G. Side panel (powdered steel or laminate)
- H. Base core
- I. Storage module
- J. Center worksurface support
- K. Lift control box
- L. Lift control pad
- M. Cable chain
- N. Leveling feet
- O. Bottom cable access
- P. Rear panel (powdered steel or laminate)
- Q. Rear core flip up cover

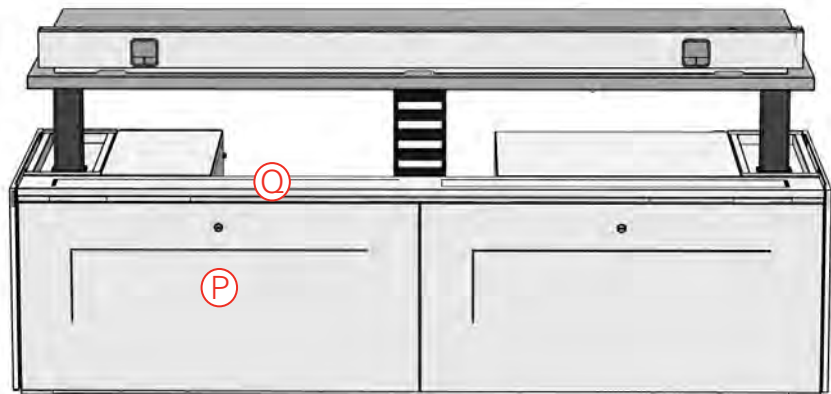
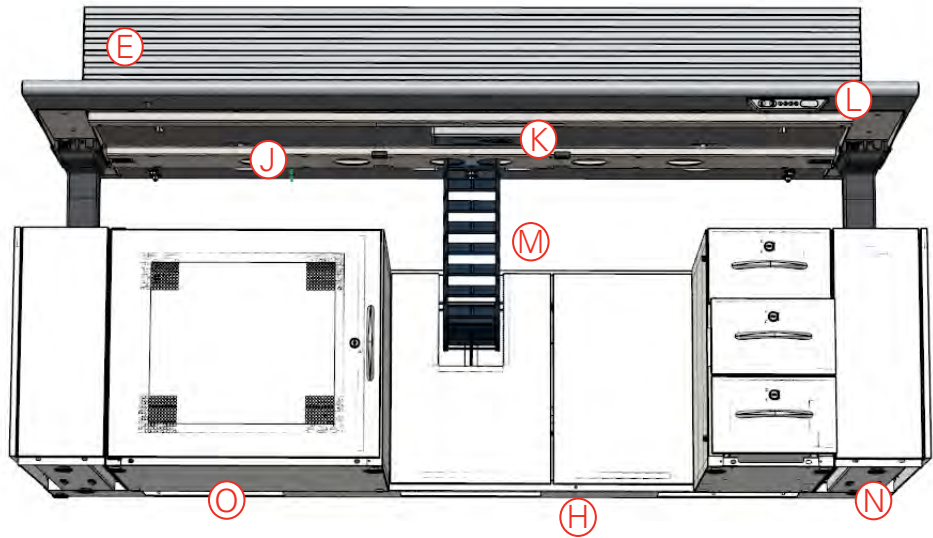
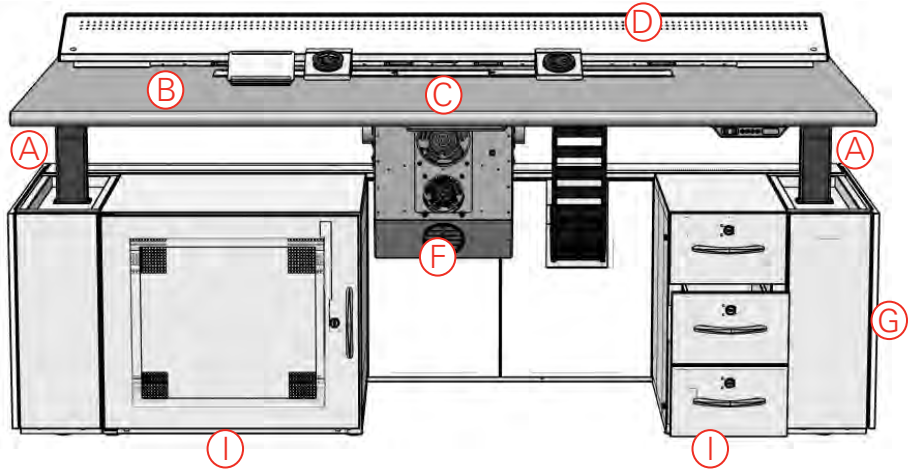

OnGuard linear inside front panel configuration layouts

72" Linear consoles:

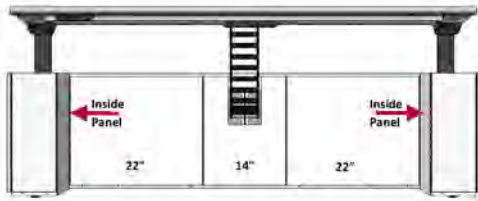

No storage

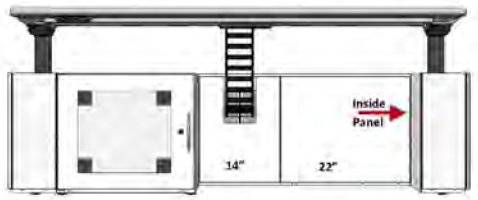

Large storage (22") Swap panels left or right

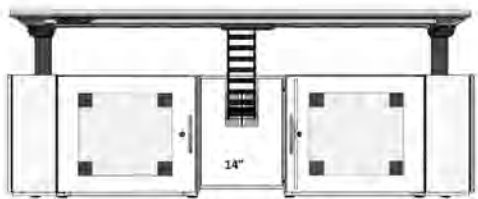

(2) Large storage (22")

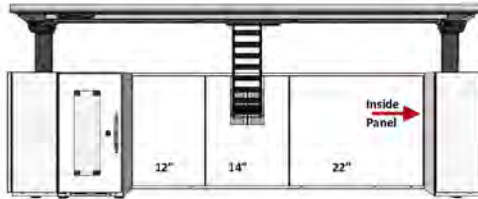

(1) Small storage (10") Swap panels left or right

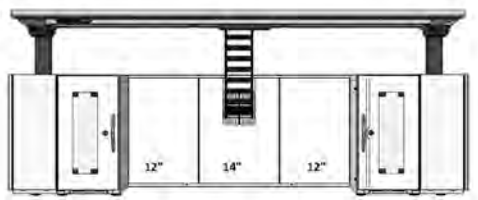

(2) Small storage (10") Swap panels left or right

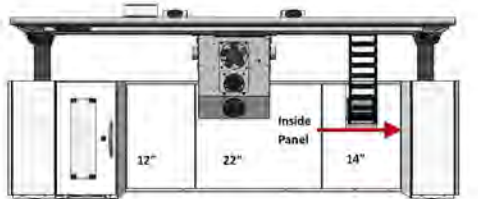

Personal environment—small storage only (10:)
Cable change offset, swap panels left or right

60" Linear consoles:

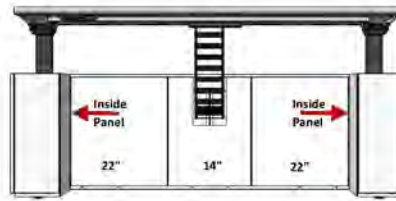

No storage

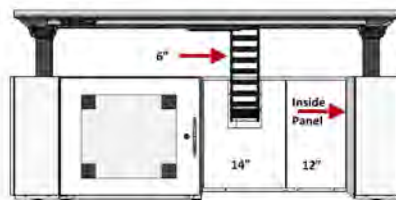

Large storage (22") Swap panels left or right

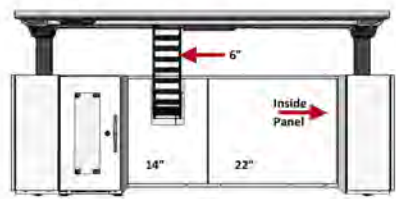

(1) Small storage (10") Swap panels left or right

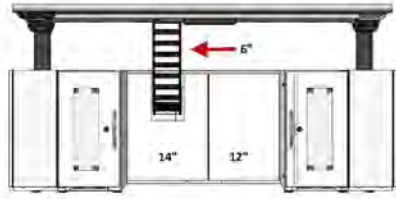

(2) Small storage (10")

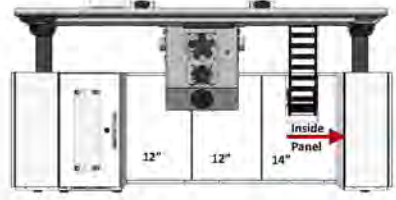

Personal environment— Small storage only
(10") Cable change offset, swap panels left or right

(2) Large storage (22") - Not applicable

48" Linear consoles:

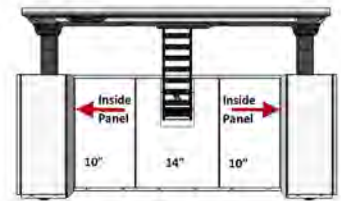

No storage

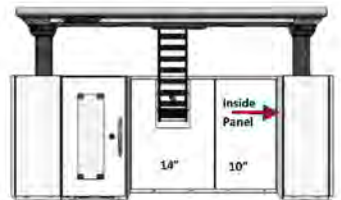

(1) Small storage (10")
(2) Large storage (22") - Not applicable
(2) Small storage (10") - Not applicable
Personal environment - Not applicable

Recommended Assembly Sequence

NOTICE

TO AVOID DAMAGING CONSOLE , FOLLOW SEQUENCE OF ASSEMBLY.

- To install a typical corner or linear work station module:
 1. Remove decorative skins from core walls, work surface support boxes and storage boxes.
 2. Assemble the base core (1 piece for linear modules; 3 base core sections for corner modules)
 3. Attach the work surface support frame
 4. Attach the work surface
- The following steps may be done after all of the work station modules are installed
 5. Attach the Techcurb (if required)

6. Attach accessory Slatwall (if required)
7. Assemble the Techtrack components (if required)
8. Install the environmental control units (if required)
9. Re-install removable skin panels and cable channel covers

General

- Assemble each main work station module completely before working on adjacent modules.
- A fully assembled work station module can be very heavy and difficult to move. Also, moving a fully assembled module can induce stresses in the module that may affect functionality of the motorized height adjustable work surfaces. Therefore, it is recommended that each work station module be fully assembled in its final intended position.
- Adjacent work station modules should be securely attached to each other before moving on to additional modules.

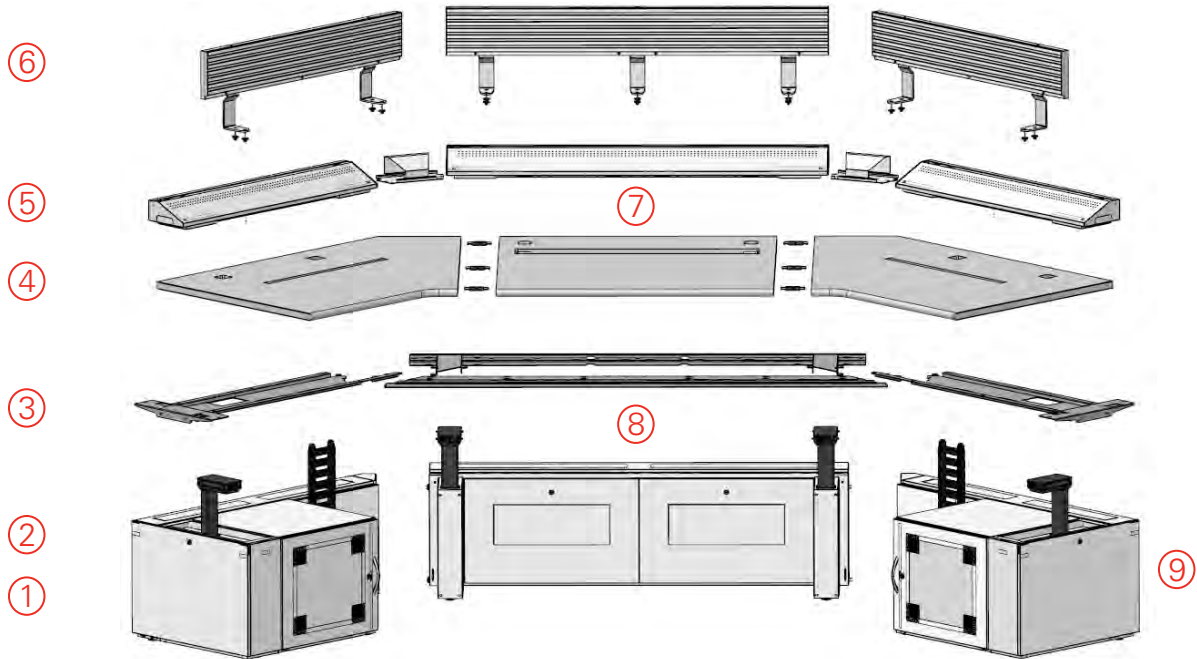

Tools required

General assembly

- Cordless screw gun (recommended)
- Magnetic driver bit holder (recommended)
- Flexible extension bit holder
- 3/8" driver bit
- Phillips driver bit
- 1/4" Nut driver (for leveling feet)
- Level

- 4mm Hex wrench (provided in hardware kit)
- 1/2" combination wrench

Personal environment system (optional)

- Flat blade screw driver (or 5/16" nut driver) for hose clamps

Personal protective equipment recommended

- Eye protection
- Work gloves
- Steel toe shoes

SECTION II - Preparing to Assemble the Console

Assembly hardware

(Reference letter noted in instructions)

Reference Letter	Description
	A ¼" x ½" hex head self-threading hex head screw (silver) (18 pcs.)
	B M6 x 14mm Allen head screws (black) (8 pcs.)
	C #10 x ¾" Phillip's head self-threading screw (black) (12 pcs.)
	D #10 x 1-¾" self-threading screw (silver) (2 pcs.)
	E #10 x ¾" Phillip's round head wood screw (silver) (56 pcs.)
	F #8 x ½" Phillip's head wood screw (black) (14 pcs.)
	G 5/16" Lock nut (nylock) (6 pcs.)
	H ¼" Lock nut (silver) (5 pcs.)
	I 14mm Festool Domino connector (6 pc.)
	J 14mm Festool Domino anchor (12 pc.)
	K Screw #10 x 1 Phillip's flat head wood screw (silver)
	L M14 Allen wrench (1 pc.)
	M Wire stay (6 pcs.)
	N Monitor pole sliding bracket (2 pcs.)
	O Center monitor pole bracket (2 pcs.)
	P Clip (1 pc.)
	Q Cable tie (8 pc.)
	R Ground cable (2 pc.)
	S ¼" Internal tooth washer

OnGuard command corner console

A. Assemble the corner console base cabinets

1. Unlock and remove rear panels from each of the base cabinets. To remove a panel, open rear cable channel cover and pull panel off from top edge.
2. Unlock and remove the end panels from the left and right base cabinets by lifting up on the panels.
3. Remove cable channel covers.
4. Position the three base cabinets as close to their final positions as possible.

NOTICE

ONCE COMPLETELY ASSEMBLED, THE CONSOLE WILL BE HEAVY AND DIFFICULT TO MOVE, PARTICULARLY ON CARPETING.

CAUTION

TO ENSURE ADEQUATE COOLING OF STORED ELECTRONIC COMPONENTS, DO NOT PLACE THE REAR OF THE BASE CABINETS CLOSER THAN 3" TO A WALL.

5. Assemble the left and right base cabinets to center base cabinet with (8) 1/4" x 1/2" self-threading hex head screws (4 screws for each flank base cabinet).
6. Adjust leveling feet to ensure top of base structure is level and aligned.

NOTICE

DO NOT OMIT ANY SCREWS. ALL SCREWS ARE REQUIRED TO ENSURE THAT CONSOLE REMAINS STABLE WHEN WORK SURFACE IS ELEVATED TO HIGHEST POSITION.

ALL LEVELING FEET OF BASE STRUCTURE MUST BE IN DIRECT CONTACT WITH THE FLOOR TO ENSURE CONSOLE REMAINS STABLE WHEN WORK SURFACE IS ELEVATED TO ITS HIGHEST POSITION.

IMPROPER ADJUSTMENT OF THE LEVELERS MAY CAUSE THE BASE CABINETS TO TWIST, RESULTING IN MIS-ALIGNMENT OF FRONT DOORS AND DRAWERS. ENSURE THAT LEVELERS ARE ADJUSTED IN SUCH A WAY AS TO ENSURE PROPER DOOR AND DRAWER ALIGNMENT.

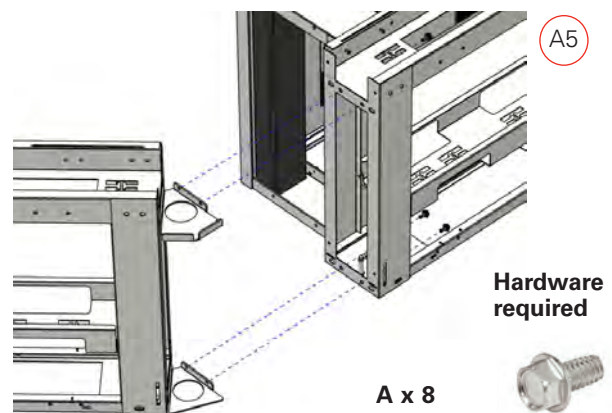
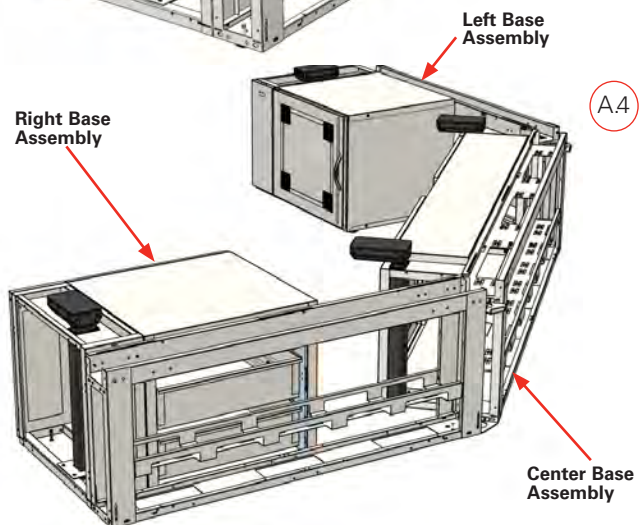
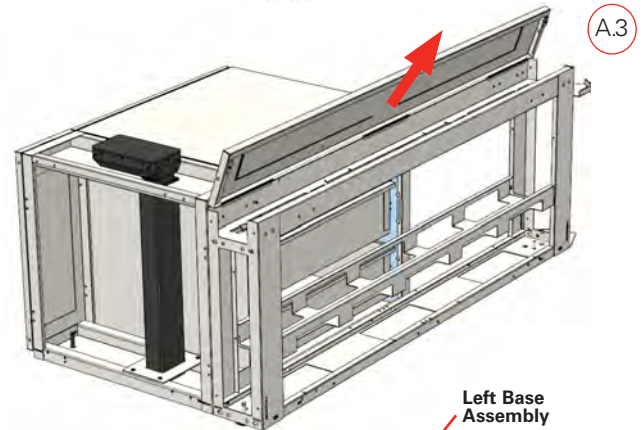
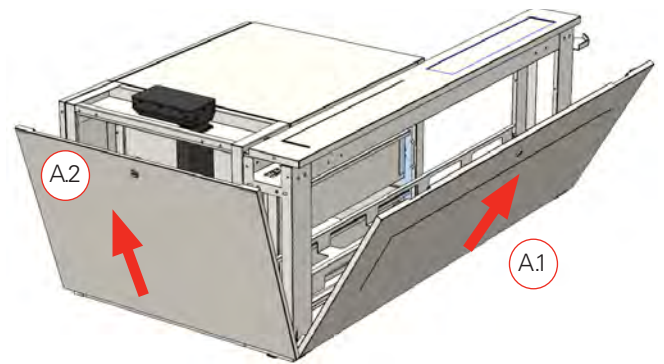

Hardware
required

A x 8

OnGuard command corner console

B. Assemble the corner console worksurface support frames

1. If the module is equipped with motorized lifting columns, proceed to step 4.
2. If the module is equipped with a set-and-forget fixed height work surface adjust the support column to the desired height.
3. The set-and-forget fixed height work surface support column is pre set to allow for 29" surface height. If adjustment is needed, there is 6" range at 1" spacing. To adjust; remove (2) 1/4" x 1/2" self-threading hex head screws. Position upper bracket to desired height, re-install screws. Follow steps B4.b - B4.d to assemble the left and right work- surface support frames to stationary supports.

NOTICE

DO NOT OMIT ANY SCREWS. ALL SCREWS ARE REQUIRED TO ENSURE THAT CONSOLE REMAINS STABLE.

4. Assemble the left and right worksurface support frames.

NOTICE

DO NOT FORCE THE SUPPORT FRAMES INTO ALIGNMENT. IF THE SUPPORT FRAMES' SCREW HOLES DO NOT ALIGN PROPERLY, LOOSEN THE SCREWS THAT ATTACH THE LEFT AND RIGHT BASE CABINET(S) TO THE CENTER CABINET. REPOSITION THE BASE CABINETS SLIGHTLY TO BRING THE WORK SURFACE FRAMES INTO ALIGNMENT. CONTINUE TO FASTEN THE WORKSURFACE SUPPORT FRAMES TOGETHER AS DESCRIBED IN STEPS 1.C, 1.D, AND STEP 2 OF THIS SECTION. THEN RE-TIGHTEN THE BASE CABINET SCREWS AFTER COMPLETING STEP 2.

- a. Partially insert (2) M6 x 14mm Allen head screws into the innermost side of each outer lift motor. Leave screws protruding about 1/4".
- b. Place the support frames into position above the outer lift motors. As you lower the frames onto the lift motors, ensure that the support frame's screw tabs are first inserted into the center worksurface frame's corresponding slots (see diagram B1.c).
- c. Attach left and right worksurface support frames to center worksurface support frame with (4) #10 x 3/8" Allen head self-threading screws (c) (2 screws for each support frame).

Hardware required



A x 2

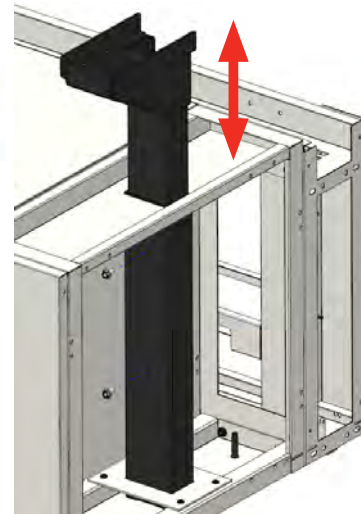

B3

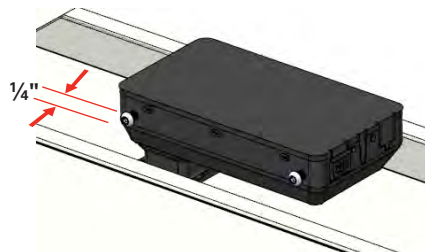

B4a

Hardware required



B x 4

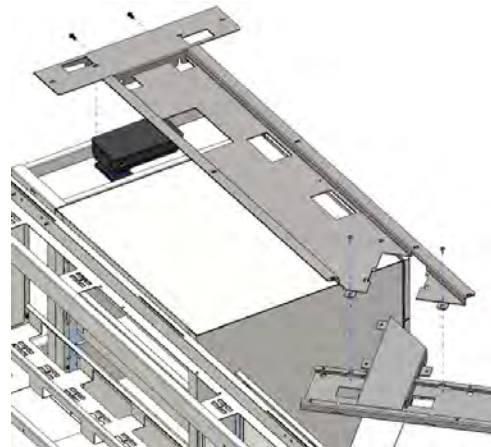

B4b

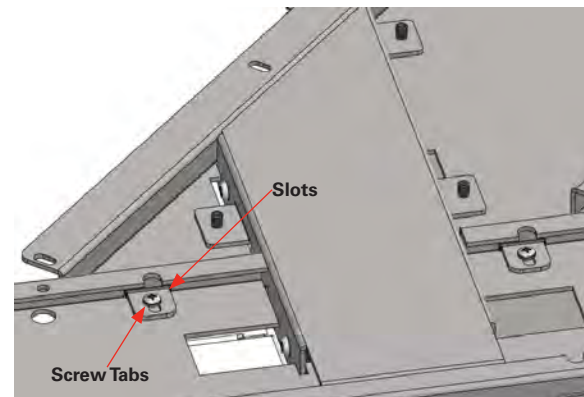

B4c

B. Assemble the corner console worksurface support frames (cont'd.)

- d. Install and tighten (3) 1/4" x 1/2" self-threading hex head screws from below at center worksurface support, left and right hand.
- e. Install and tighten (4) additional M6 x 14mm Phillip's head screws (2 for each motor) to complete attachment of support frames. Tighten inner motor screws. Complete the same step for stationary support legs as well. (4 places).
- 5. Assemble front worksurface stiffener to support frames with (2) 1/4" x 1/2" self-threading hex head screws.

NOTICE

DO NOT OMIT ANY SCREWS. ALL SCREWS ARE REQUIRED TO ENSURE THAT CONSOLE REMAINS STABLE.

Hardware required



A x 3

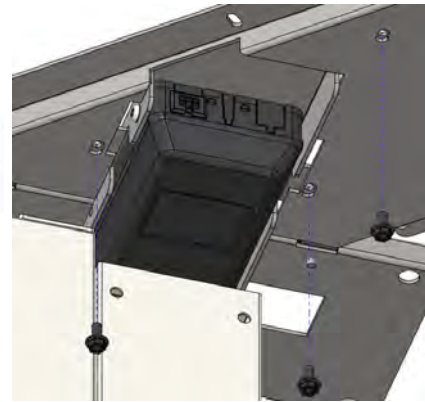

B4.d

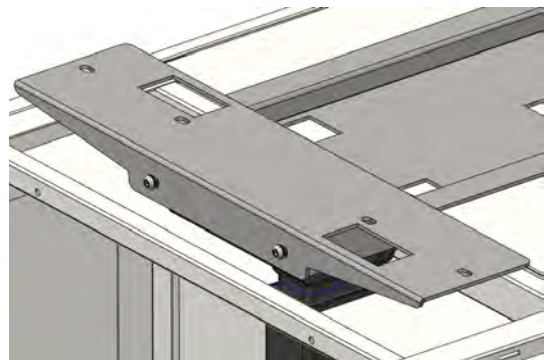

C.1

Hardware required



B x 4

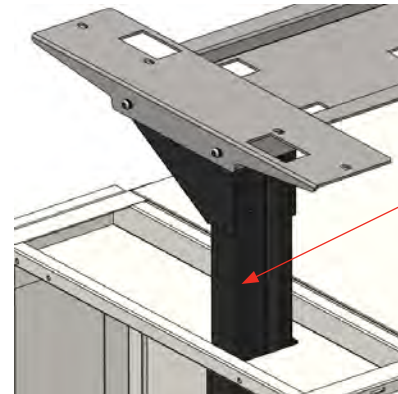

B.4e

- 2. Assemble front worksurface stiffener to support frames with (2) 1/4" x 1/2" self-threading hex head screws.

Hardware required



A x 1

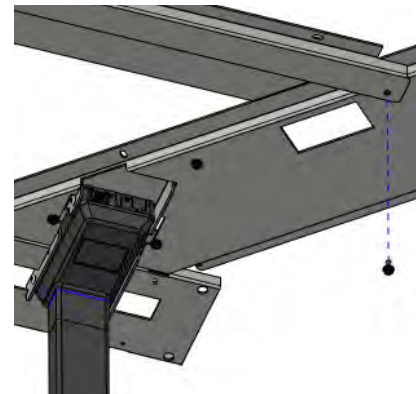

B.5

C. Install and connect the lift motor components

1. Plug the power supply cable into the lift control box receptacle. Loop the power supply cable into the "U" shaped strain relief slot on control box. Then attach control box to front worksurface stiffener with (2) #10 x 1 - 3/4" self-threading screws, as shown in figure C.1.

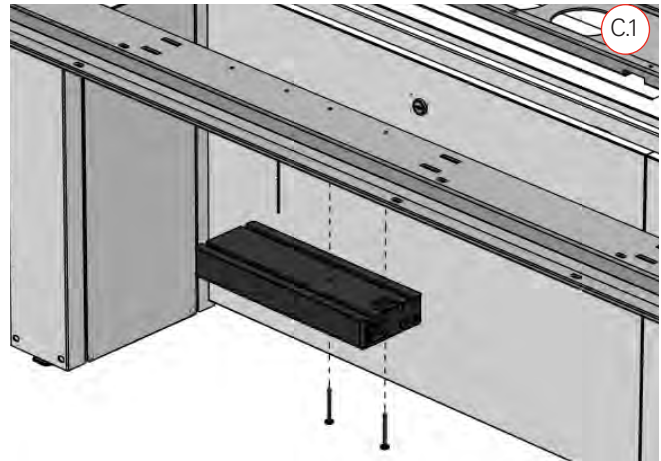

2. Route the power cord from the control box into the left support frame channel, and then through the center worksurface support frame, as shown in figure C.2. (If no Tech Curb included, route through flank supports to nearest cable chain, then down to core and available power source)

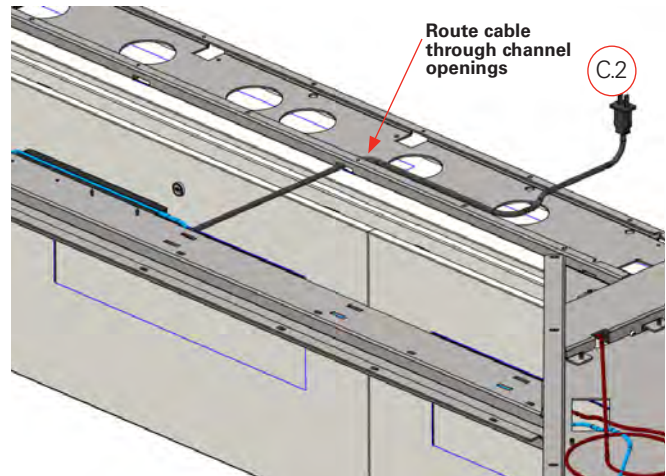

NOTICE

IN ORDER TO ENABLE EASY LIFT MOTOR DIAGNOSTICS (IF EVER REQUIRED), THE LIFT MOTORS MUST BE PLUGGED INTO THE CORRESPONDING NUMBERED RECEPTACLES ON THE CONTROL BOX. THE LIFT MOTOR NUMBERS ARE SHOWN IN THE DIAGRAM AT RIGHT.

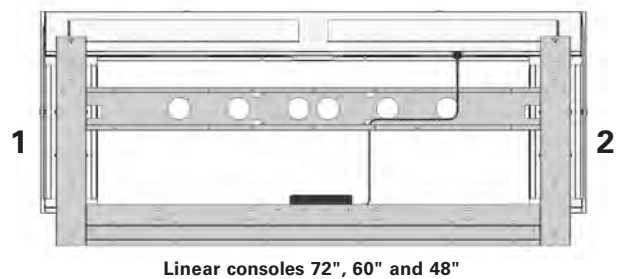
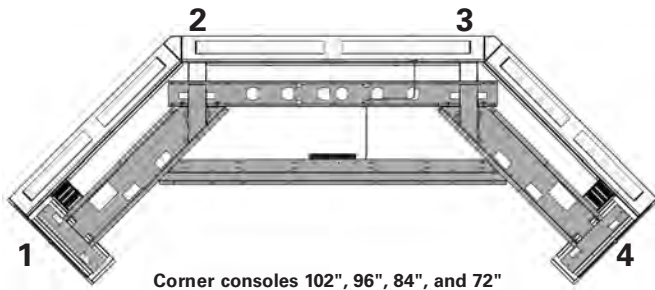
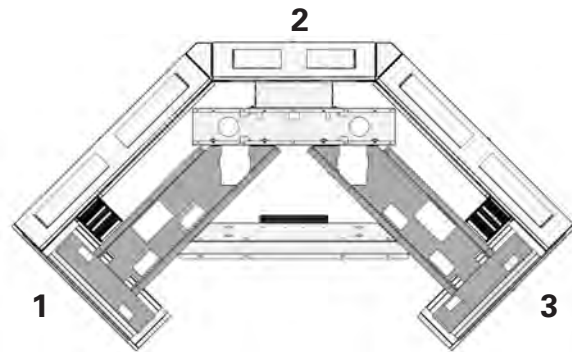

- Route (2) lift motor cables from the rear lift motors (# 2 and 3) to the control box, plugging the cables into the appropriate numbered receptacles in the control box. (Motor cable #2 is shown; motor cable #3 will follow a similar path through the right support frame).

Loop excess cable in support frame channel

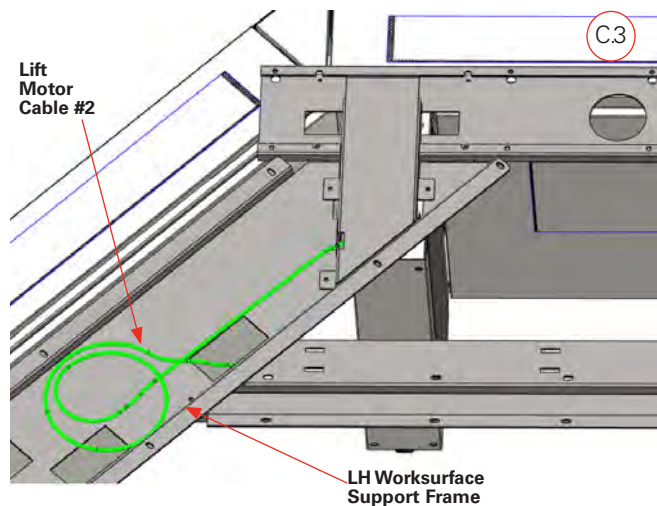
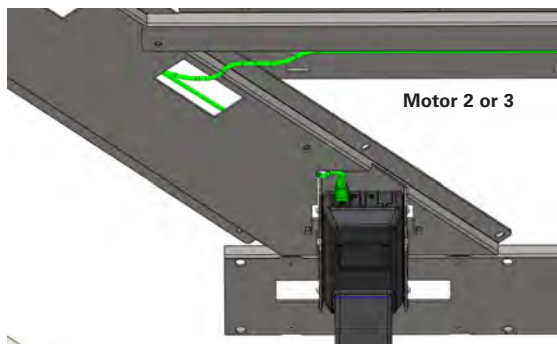

- Route (2) lift motor cables from the outer lift motors (#1 and #4) to the control box, plugging the cables into the appropriate numbered receptacles in the control box. (Motor cable #1 is shown; motor cable #4 will follow a similar path through the right support frame.) The cable for lift motor (#4) should be inserted into the control box's cable retention groove to neatly reach the opposite side of the box.

Loop excess cable in support frame channel

Motor 1 or 4

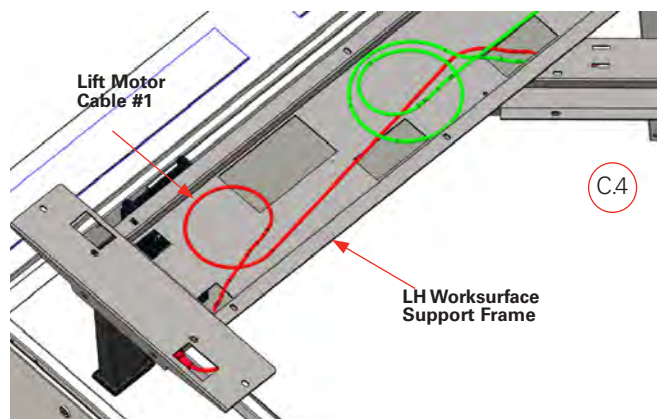
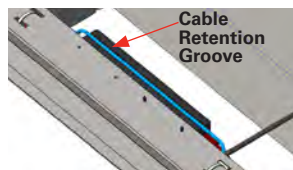
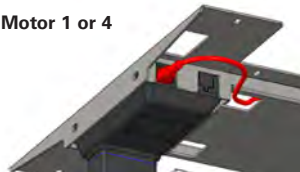

- Plug the lift control pad into the control box, routing the cord as shown. The control pad can hang freely until the worksurface is installed. (The control pad may also be routed to the left side of the console if desired.)

Loop excess cable in support frame channel

- Neatly retain exposed cables to front worksurface stiffener with supplied cable "zip-ties." Gather any excess cable length and secure in left and right worksurface support frames before worksurface is attached.

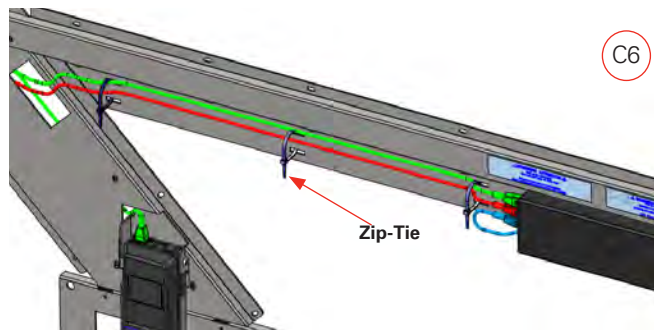
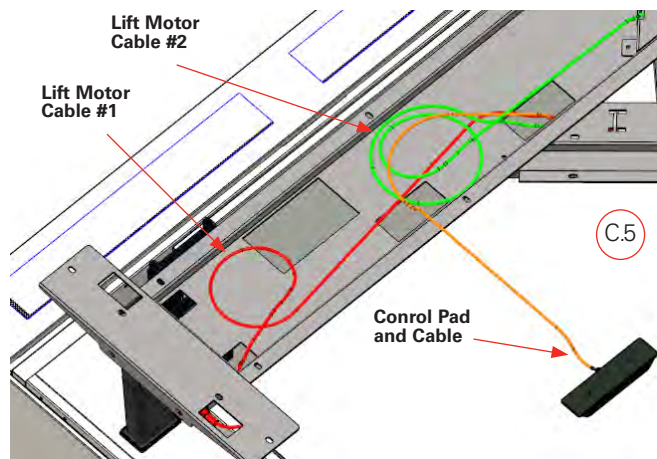

7. Linear consoles are wired in similar fashion as the corner consoles. Install the control box (2 port) and route the power cord the same as noted in C1 and C2.

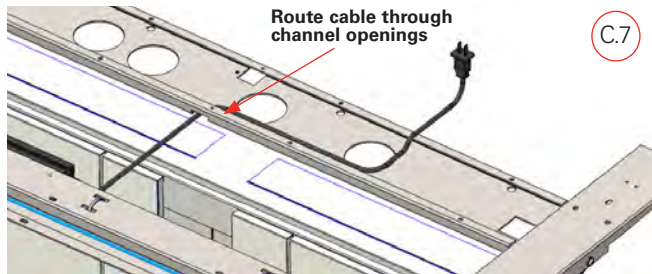

8. Route (2) lift motor cables from the outer lift motors (#1 and #2) to the control box, plugging the cables into the appropriate numbered receptacles in the control box. (Motor cable #1 is shown; motor cable #2 will follow a similar path through the right support frame.)

Route the control cord as shown. The control pad can hang freely until the worksurface is installed. (The control pad may also be routed to the left side of the console as well.)

- 8a. Loop excess cable in support frame channel from top.

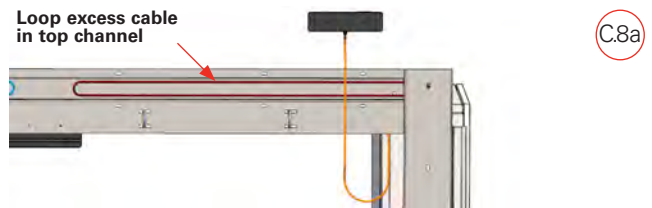
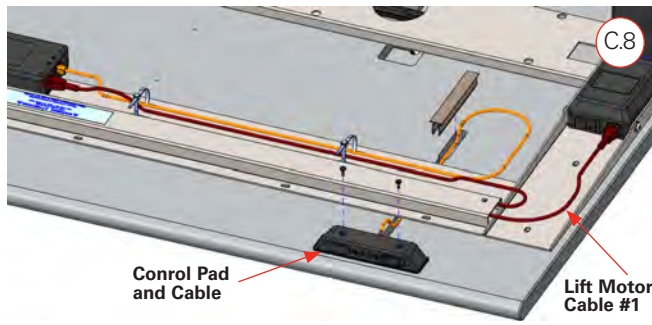

D. Initialize the lift motor systems

WARNING

BEFORE ENERGIZING OR OPERATING THE LIFT SYSTEM

- MAKE SURE THAT THE PRECEDING ASSEMBLY STEPS HAVE BEEN FOLLOWED AND ARE COMPLETED.
- VERIFY THE CORRECT POSITION OF ALL LIFT MOTOR CONNECTORS. VERIFY THAT ALL LIFT MOTOR CABLES ARE PROPERLY SEATED IN THEIR RECEPTACLES.
- MAKE SURE THAT THE VOLTAGE OF THE CONTROL BOX IS CORRECT BEFORE THE SYSTEM IS CONNECTED TO THE MAINS.

To initialize the lift motor system:

1. Temporarily plug the power cord into a nearby 120 volt AC outlet.
2. The lift motor system is initialized by pressing and holding the down button. The motors will automatically lower to their bottom most position (if not already there), then run upwards approx. 3 mm, and then down again to their lowest position. Only release the down button when the movement has completely stopped.
3. If the button is released before the sequence is completed then the initialization is interrupted and must be started again from the beginning.
4. It is sometimes necessary to press the down button twice to start the initialization. This is because the system can be in different modes when the initialization starts.
5. After initialization, press the up button to lift the worksurface support structure about 18 inches in order to allow access to the underside of the support structure.

WARNING

- IF THE CONTROL BOX MAKES UNUSUAL NOISE OR ODORS, IMMEDIATELY UNPLUG THE UNIT FROM THE AC RECEPTACLE.
- INSPECT ALL CABLES TO ENSURE THAT THEY ARE NOT DAMAGED. RECORD ALL ERROR CODES SHOWN.
- DO NOT PLUG THE UNIT IN AGAIN. CONTACT TECHNICAL ASSISTANCE FOR HELP USING THE CONTACT INFORMATION IN SECTION 1 OF THE INSTALLATION GUIDE.

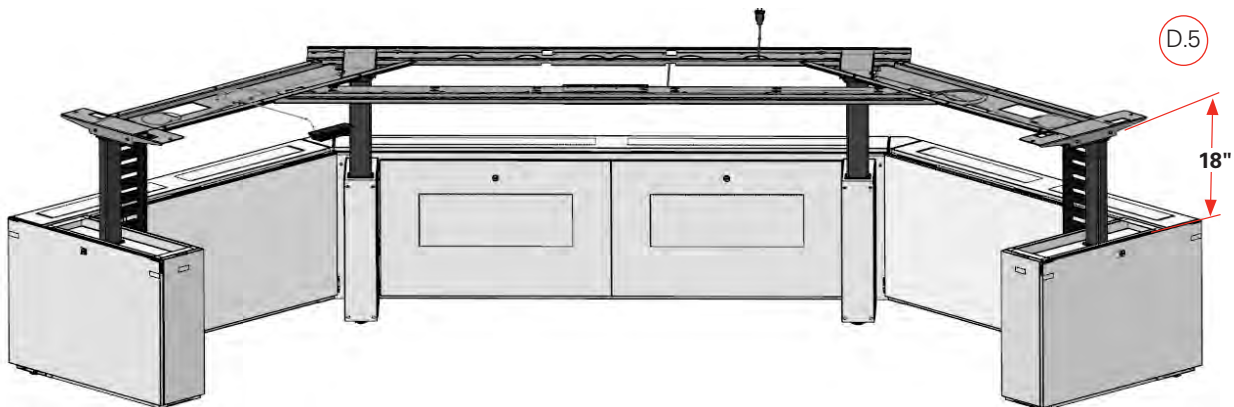

E. Install the worksurface



UNPLUG THE POWER CORD FROM THE AC OUTLET BEFORE PROCEEDING.

The 102", 96", 84" and 72" console worksurfaces are comprised of three pieces that must be fastened together, utilizing supplied hardware. The 66" and 60" console worksurfaces are single pieces.

1. Carefully unpack the worksurface(s) and place the worksurface(s) down on a protective surface.
2. Both notched and un-notched plastic trim strips are provided. Insert the (2) notched trim strips onto the edges of the rectangular opening in the center worksurface. The flexible tabs on the trim strips should be flush with the decorative writing surface of the worksurface.
3. Insert the (2) un-notched trim strips onto the edges of the rectangular slots in the left and right worksurfaces. The flexible tabs on the trim strips should be flush with the decorative writing surface of the worksurface.

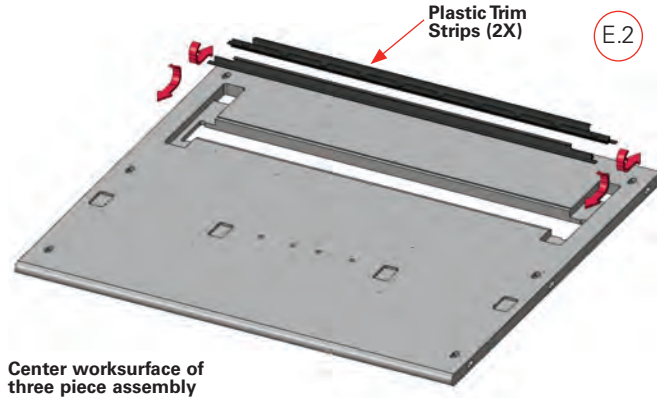

Center worksurface of three piece assembly

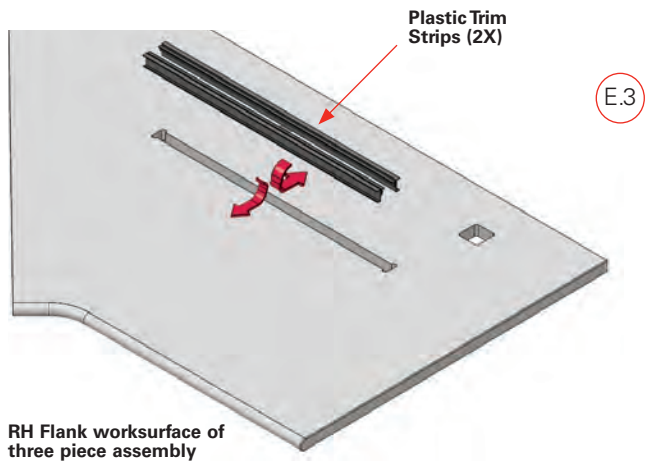

RH Flank worksurface of three piece assembly

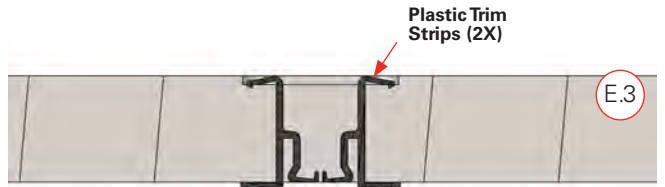

For three piece worksurface follow steps 5. and 6. For single piece worksurface proceed to step 7.



LIFT AND POSITION THE PANELS OF A THREE PIECE WORK-SURFACE ONTO THE CONSOLE SEPARATELY. DO NOT ATTEMPT TO FASTEN THE PANELS TOGETHER BEFORE LIFTING AND POSITIONING THEM.

THE FOLLOWING STEPS WILL NEED TO PERFORMED FROM UNDERNEATH THE WORKSURFACES.

5. Insert (6) Domino anchors (J) and (6) Domino connectors (I) into the center worksurface oval slots as shown. Tighten set screw in anchor using the provided M14 allen wrench.
6. Insert (3) Domino anchors (J) into slots on both the left and right hand worksurfaces. (use small tape to help hold anchors in place). Align connectors and connect worksurface sections together. Tight- en all set screws in anchor using the provided M14 allen wrench (L). This will pull sections together. Ensure surfaces are aligned before tightening.

Ensure that the lift control pad cable sits in the groove in the outer worksurface.



AS YOU POSITION THE WORK SURFACE(S) ONTO THE CONSOLE, MAKE SURE THAT NONE OF THE PREVIOUSLY ROUTED CABLES BECOME PINCHED.

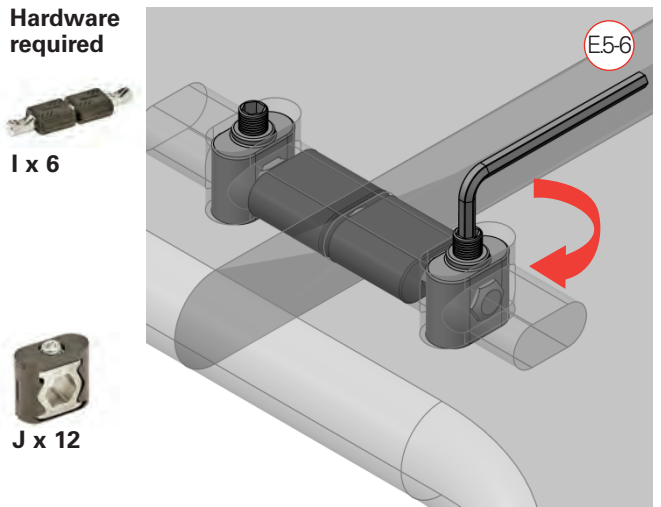
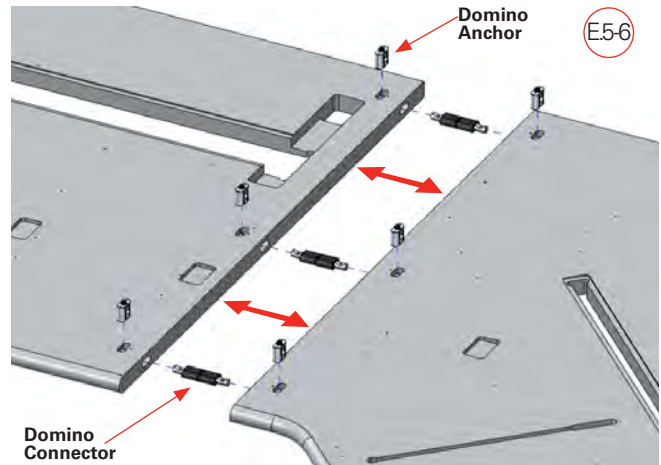
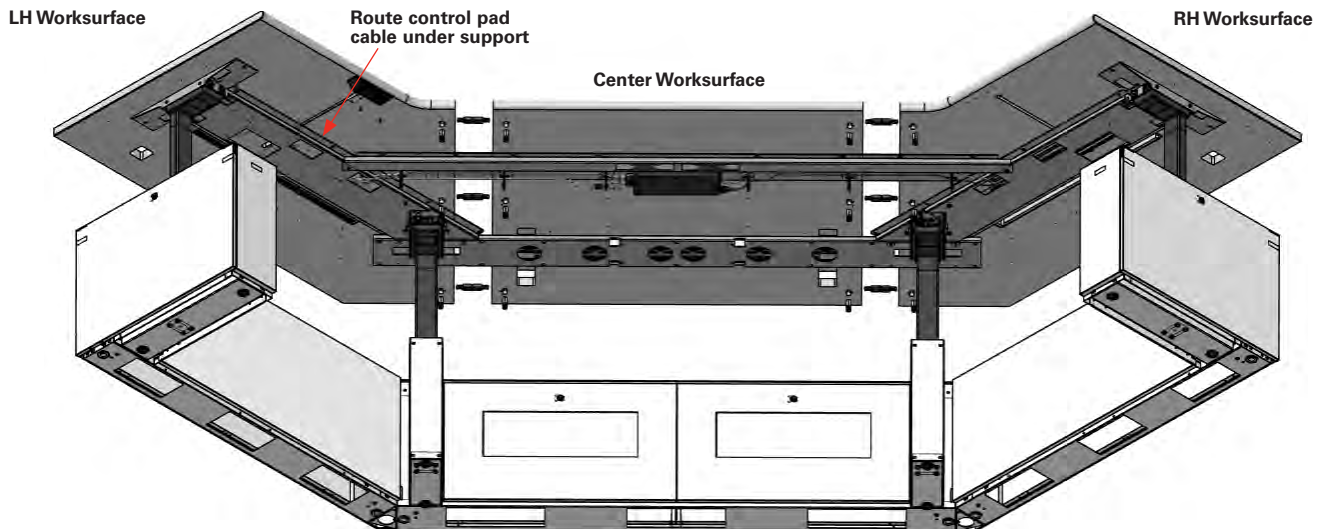

- Position single piece worksurface onto the support frames.
Align mounting holes in worksurface and support frame.



AS YOU POSITION THE WORK SURFACE(S) ONTO THE CONSOLE, MAKE SURE THAT NONE OF THE PREVIOUSLY ROUTED CABLES BECOME PINCHED.

- Check to see if the bottom of the worksurface assembly sits flush against ALL of the worksurface support frames. If not, re-level the base cabinets as required to bring the components into alignment.

Ensure that the lift control pad cable sits in the groove in the outer



DO NOT TWIST OR FORCE THE WORKSURFACE INTO ALIGNMENT WITH THE SUPPORT STRUCTURE. THIS CAN BUILD STRESS INTO THE SYSTEM AND AFFECT THE LIFTING ACTION.

- Align mounting holes in worksurface and support frame an attach the worksurface to the support frame with 3/4" Phillips head wood screws (E).
- Attach the control pad to the worksurface with (2) #8 x 1/2" Phillips head wood screws (F). Retain the cable in the adjacent slot with the plastic clip supplied
- Lift the free ends of the cable chains and attach the cable chains to the underside of the worksurface using #10 x 1 Phillips flat head wood screw (2) per cable chain (K).

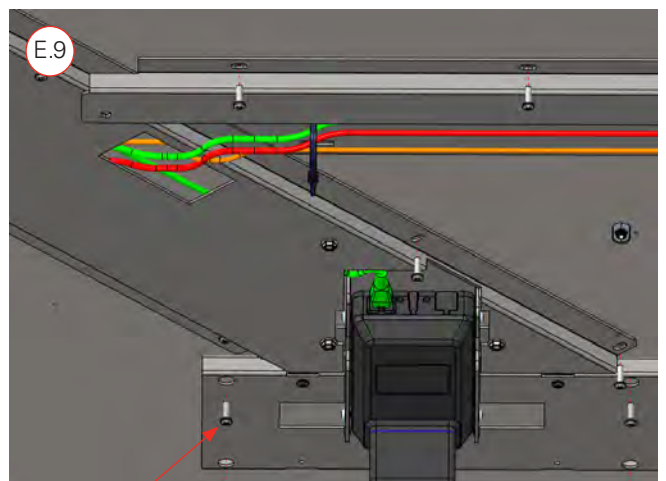
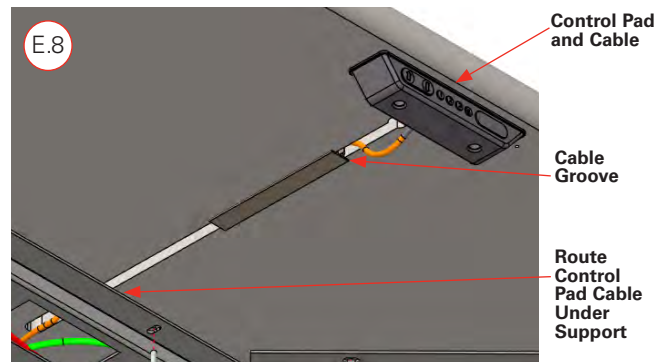
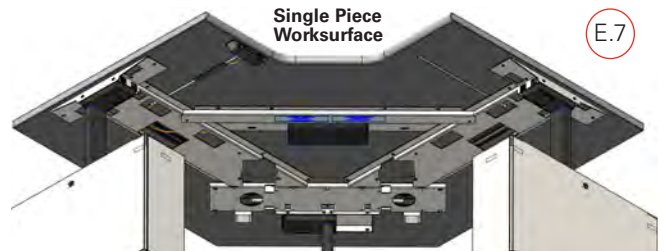

Hardware required



K x 2

Hardware required



E Type



F x 2

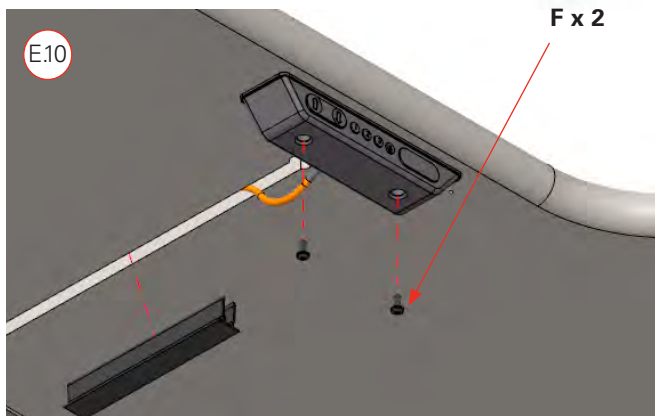
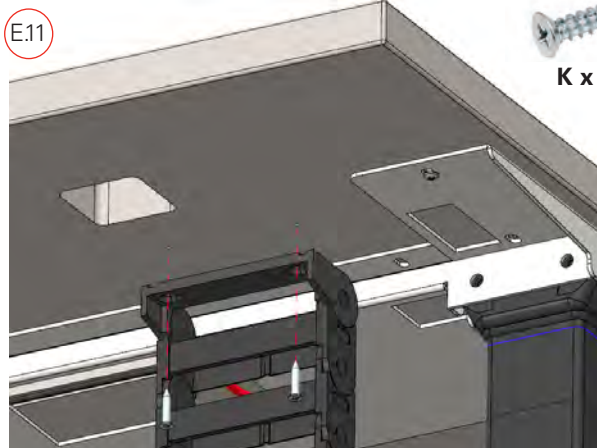

F. Install Optional TechCurb / Slatwall

1. Position the three TechCurb sections along the rear edge of the worksurface, aligning the square cutouts in the TechCurb base with square holes in the worksurface.

The oval mounting holes allow repositioning of the curb sections to ensure proper alignment with each other.

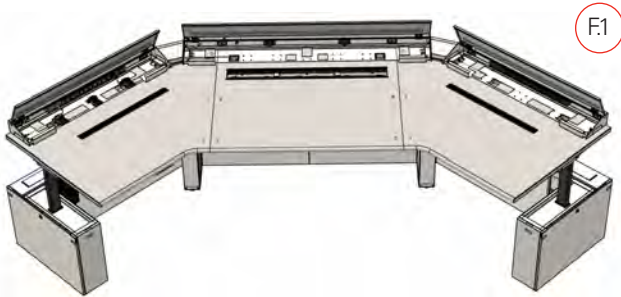

F.1

2. Remove knock-out cable pass holes on TechCurb ends to allow for cable pass through at the corners and to allow for assembly of the 45 degree connector tunnels.

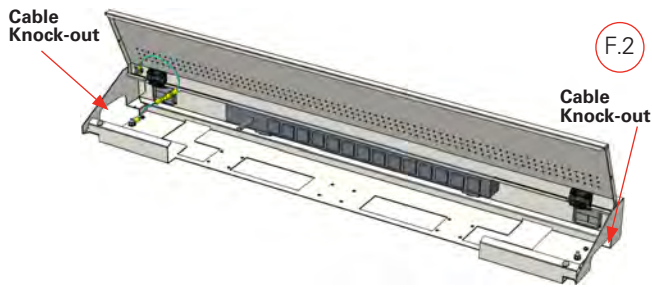

F.2

3. Position the 45 degree TechCurb connector tunnels in between the TechCurbs at the corners. (2X) on the 102", 96", 84" and 72", (1X) on the 66" and 60", not included on linear units. Attach the TechCurbs and connector tunnels to the worksurface with (12) 3/4" Phillip's head wood screws, (4) per section.

Hardware required E x 12

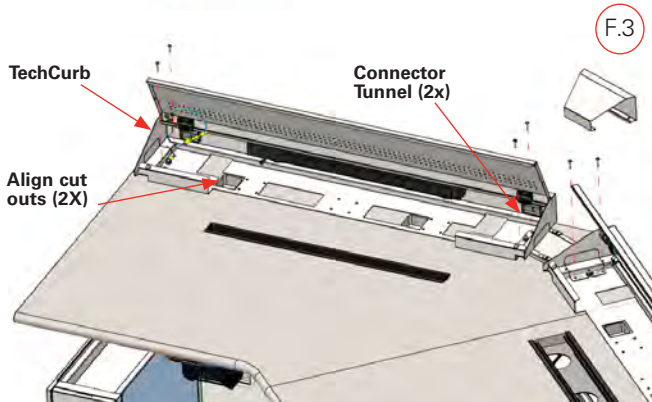

F.3

4. Ground bonding studs are installed in each TechCurb, as well as, a 10 foot ground wire in the RH and LH Techcurbs. Shorter ground wires are also attached to the TechCurb lid. Place the loose end of the RH and LH TechCurb ground wire onto the threaded stud and then secure the ground bonding wire with (1) #1-4-20 lock nuts, (H).

Route the free end of the 10 foot ground wire through the cable chains and then to the base core Protective Earth Terminal (PET). The PET is indicated with a Ⓧ symbol. Refer to section V.A for instructions on connecting the ground wire to the Protective Earth Terminal (PET).

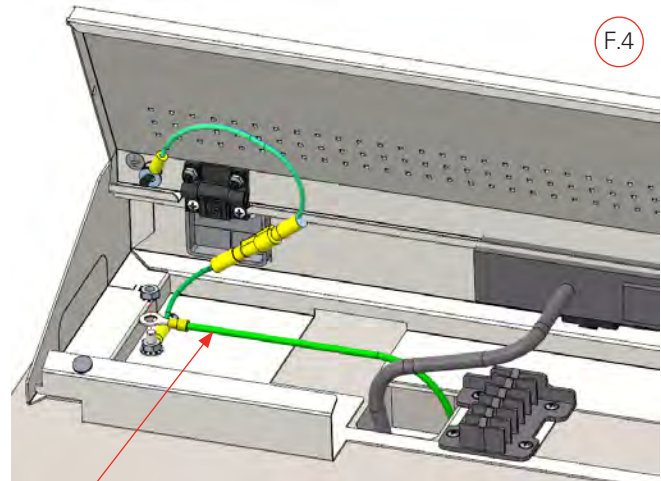

F.4

10' Ground Wire

Hardware required



H x 6

WARNING

TO ENSURE ELECTRICAL GROUND CONTINUITY THROUGH THE ENTIRE TECHCURB, THE GROUND CONNECTIONS AS DESCRIBED ABOVE IN SECTION F.2 MUST BE MADE.

NOTICE

THE TECHCURB LIDS HAVE FRICTION HINGES THAT HOLD THE LIDS IN A FULLY OPEN POSITION. THE TENSION OF THE HINGES MAY BE INCREASED BY TURNING THE HINGES' CENTER ADJUSTMENT SCREWS CLOCKWISE.

- Pull the lift motor power cord up through the center worksurface opening, and into the TechCurb. Route cord through openings via corner connector tunnels. Plug the cord into the closest TechCurb power strip. Wire stay clips can be installed into multiple positions on the bottom of the TechCurb to retain power cords and data cables. Attach each clip with (2) #8 Phillips head wood screws.

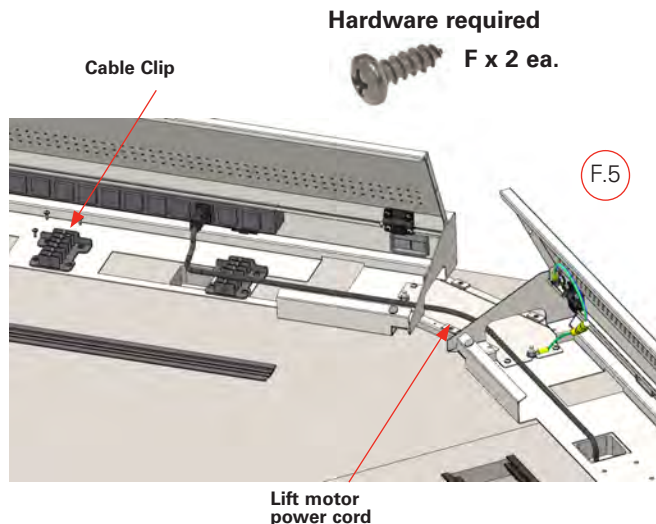

- Route the power strip's electrical cords down through the cable chains into the base structure. Ensure that the power cords are fully inserted into the cable chains

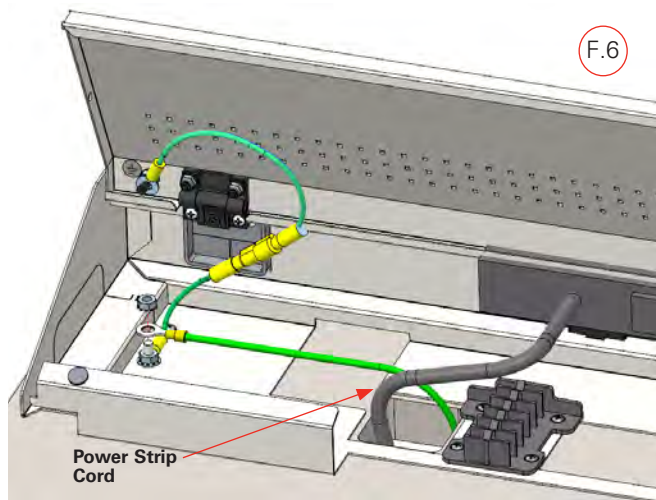

MAX MONITORS PER SLATWALL SECTION: 68" (3), S6",S3",44" (2X), 36",32" (1X). MAX MONITOR WEIGHT 25 LBS.

- Installing Slatwall - Align the Slatwall support legs with the openings in the TechCurbs. Mark the center of the square holes (4X) per section. Remove and drill (4) .250 dia. holes through the worksurface.

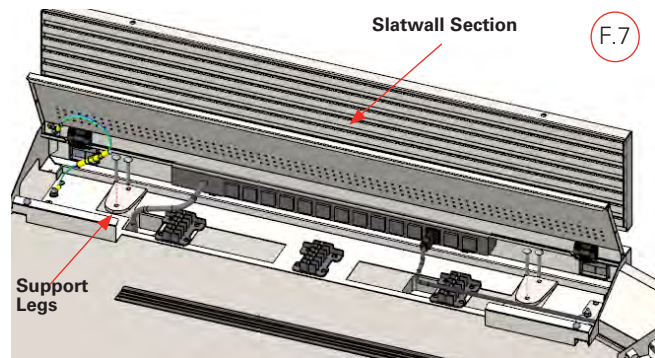

- Align the Slatwall and insert (4) 1/4-20 x 2 Carriage Bolts (supplied with Slatwall) into square holes in support legs, through worksurface.

- Secure from bottom of worksurface with (4) 1/2" Flat Washer, (4) 1/4" Flat washer, and (4) 1/4-20 Nylon Lock Nuts. (supplied with Slatwall) Stack hardware as noted, tighten securely. Route any cables from monitors through cable ports located at the back of the TechCurbs. Plug Monitor power cords to closet power strip. All other cables should be routed through the TechCurb, cable chain, the base core and CPU storage as needed.

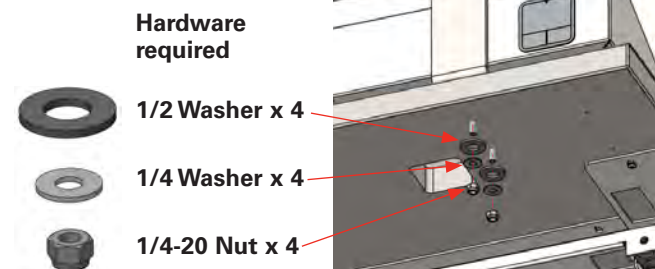
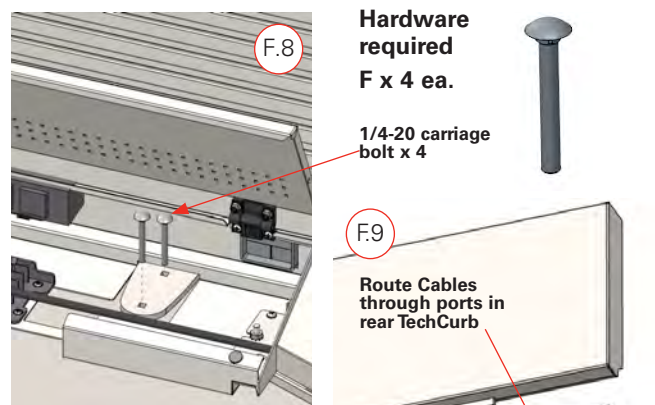

G. Install rear corner covers

The bottom rear corner cover(s) may be left un-installed to enable cable ingress at the corner(s).

1. Install (4) lower #10 x $\frac{3}{8}$ " Phillip's head self-threading screws as shown. Leave the screws protruding about $\frac{1}{16}$ ".
2. Lower the bottom corner cover onto the two screws, engaging the screws in the slots in the cover.
3. Secure the cover with two additional top screws.
4. Engage the upper corner cover's hooks into the slots and then lower the cover into position.

Hardware required



C x 8

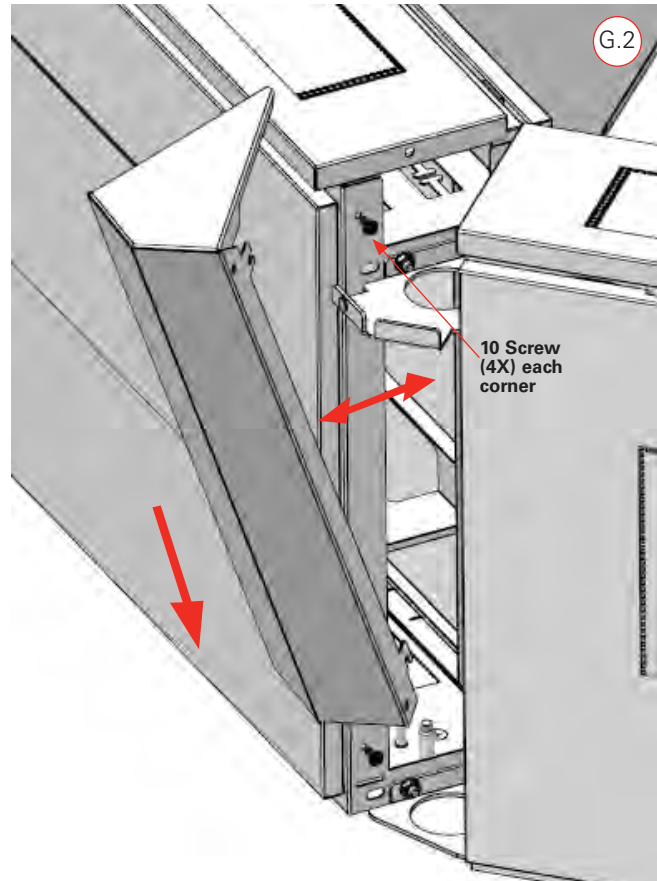

A. TechTrack components

1. A variety of 4" and 8" wide TechTrack module styles are available to customize the TechTrack. The OnGuard command console ships with (4) blank module covers and (1) monitor pole module. All of the modules simply snap into the grooves in the center TechTrack trim strips.

Optional connectivity module

2. Connectivity modules are available in 4" (3 jack) and 8" (6 jack) widths. The module accommodates standard low voltage keystone style snap-in connectors (not included).

Optional personal environment system outlet module

See section IV.C (page 27) of this manual.

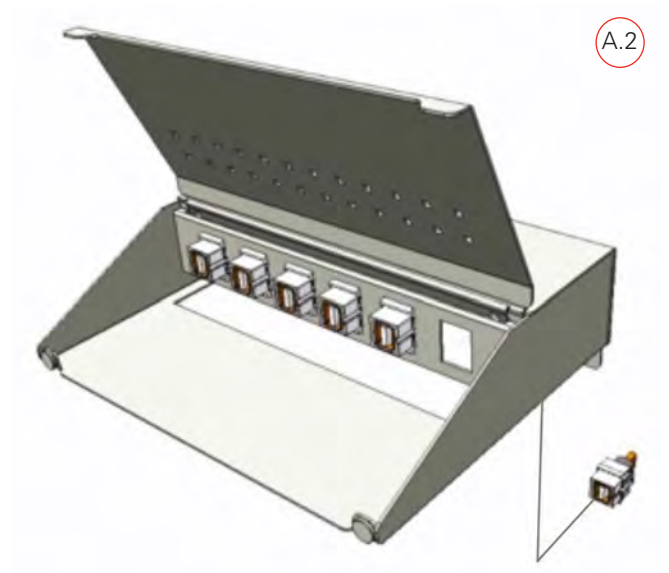
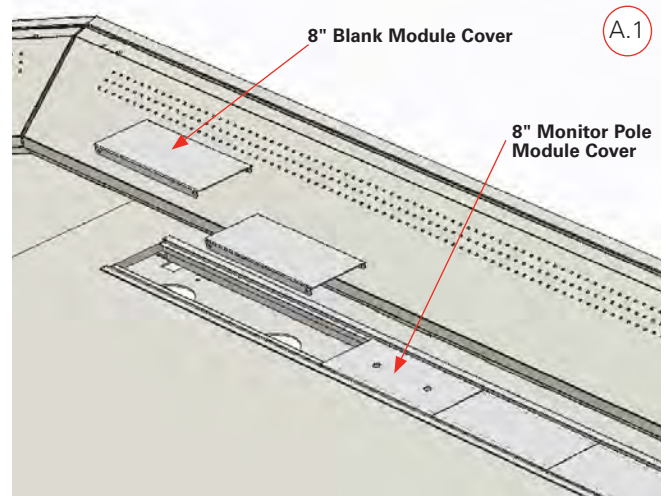

B. Monitor poles

Monitor poles will be shipped in separate carton(s), along with their associated hardware, parts and installation guide. Carefully un-pack the poles from the carton(s).

NOTICE

PLACE ALL SEPARATELY PACKED INSTRUCTION AND INSTALLATION GUIDES INTO THE COMPLETED CONSOLE SO THAT THEY WILL BE AVAILABLE TO THE END USER OF THE CONSOLE.

To install a monitor pole onto the center worksurface:

Position the 2 center monitor pole brackets into the TechTrack, with the 2 threaded studs protruding through the monitor pole module plate. (The monitor pole module plate is usually located in the center position; tabs on plate will register it in position). See figure B. Refer to the pole attachment steps in the next section.

To install a monitor pole:

1. Assemble the monitor pole base plate onto the pole with (4) Phillip's flat head screws (included with the pole).
2. Position the pole onto the (2) protruding studs and secure with (2) 5/16 nuts. Then slide the decorative bottom trim cover over the top of the pole, down onto the base plate.
3. Follow the instructions provided with the monitor pole to attach support arms and monitors.

Hardware required



G x 2 ea.

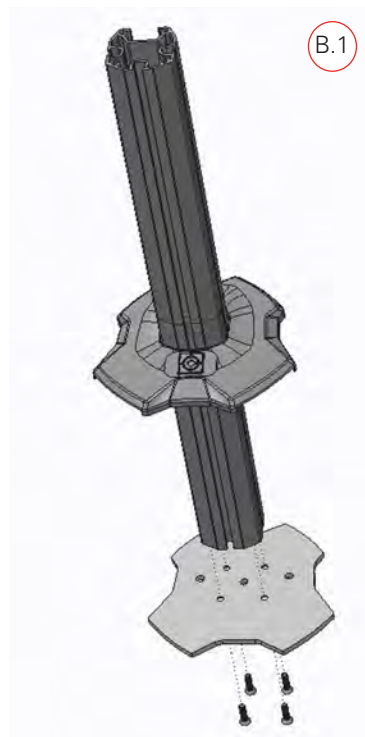
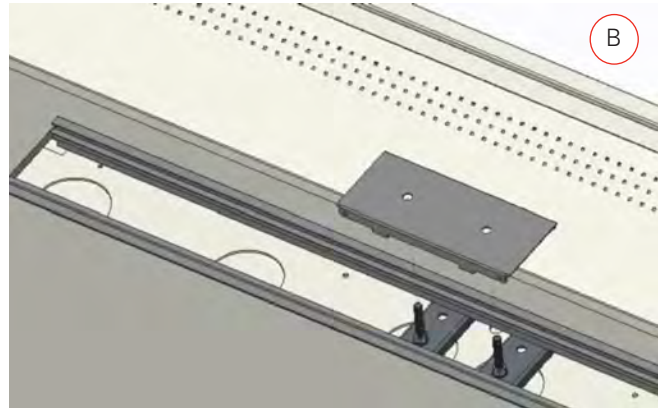

Hardware included with each monitor pole (4) Phillip's flat head screws

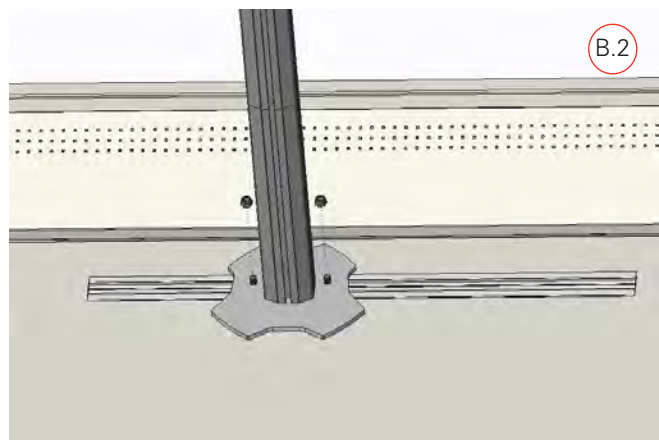

C . Personal Environment System

OnGuard consoles may be ordered with an optional personal environment system. When so equipped, the center base cabinet will not have doors. Instead, there will be a removable rear panel in the open well that accommodates the environmental control unit.

The personal environment system will be shipped in a separate carton, along with its associated hardware, parts and user manual. Carefully unpack the unit from its carton. Some of the supplied hardware may not be required for this installation. Operating instructions are supplied in the box with the personal environment system.

NOTICE

PLACE ALL SEPARATELY PACKED INSTRUCTION AND INSTALLATION GUIDES INTO THE COMPLETED CONSOLE SO THAT THEY WILL BE AVAILABLE TO THE END USER OF THE CONSOLE.

1. Attach the personal environment system to the underside of the rear worksurface support frame with Tech Curb (4) 1/4" x 1/2" self-threading hex head screws.
2. Plug the supplied AC power cord into the unit and then route the cord up into the TechTrack as shown, and then into the TechCurb. Plug the cord into one of the TechCurb's power strips.

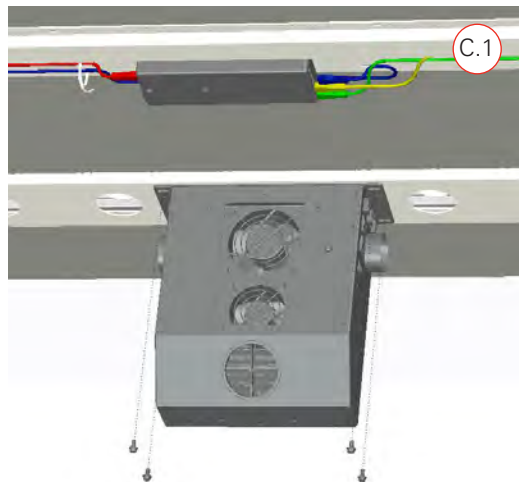

Hardware required



A x 4

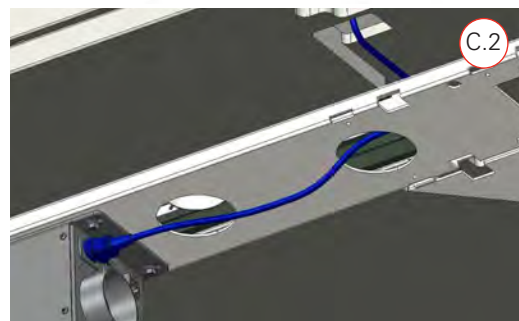

3. Run the personal environment system touchpad cable down into the TechTrack, then down to the control unit receptacle as shown.

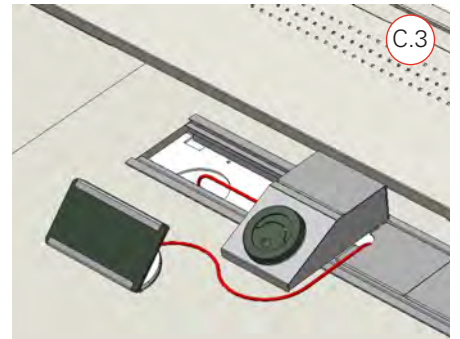

4. Two air outlet TechTrack modules are provided. Snap the plastic air registers into the modules' holes.

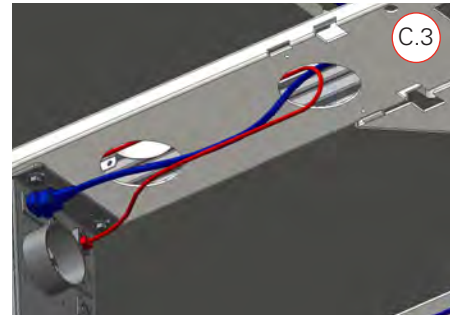

5. Attach a corrugated duct onto the plastic collar on each outlet module using the supplied hose clamps.

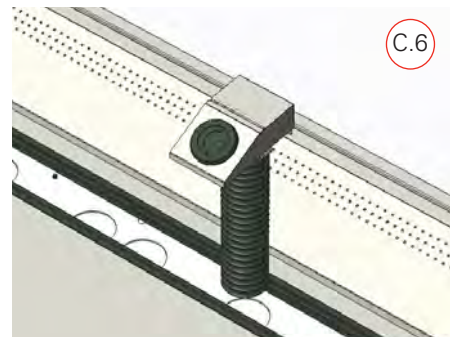

6. Snap the air outlet modules into the TechTrack, dropping the flex ducts through large holes adjacent to the personal environment system.
7. Attach the open ends of the flex ducts to the outlet collars on the personal environment system using the supplied hose clamps.

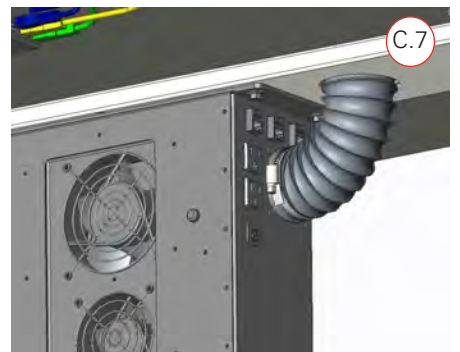

D. Task light bracket

This accessory is intended for use with the following furnishing components:

- OnGuard Command Console Monitor Pole:

Description #	Part #
20" Monitor mounting column & base plate kit	KONWLC20B
30" Monitor mounting column & base plate kit	KONWLC30B
Pitch/pivot column head kit	KONWLK0B
Dynamic height adjustable column arm kit	KONWLK1B
Articulating column arm kit	KONWLK2B
Articulating dual monitor array column arm kit	KONWLK2DUOB
Large universal interface bracket	TOACJSBUB

- Revo LED Light #TOALTASREVD AND #TOALTASREVDS with #TOALTASREVSM Surface Mounting Bracket
- Trillium LED Light #TOALTLED

NOTICE

Task light bracket assembly

The task Light Bracket can be attached to any side of the monitor pole.



To attach the bracket to the front or sides of the monitor pole:

1. Remove the monitor pole's top cap.
2. Install (2) ¼-20 x ½" Allen head screws into the bracket as shown. Partially thread (2) ¼" lock nuts onto the screws.
3. Slide the nuts down into the pole's "T" channel to the desired height, then tighten the (2) screws with the provided Allen wrench. Replace the pole's top cap.



To attach the bracket to the rear of the monitor pole:

1. Remove the monitor pole's top cap.
2. Install (2) ¼ x ½" Allen head screws into the bracket, partially threading them into the clamp plate as shown.
3. Slide the assembly down into the pole's rear channel to the desired height, then tighten the (2) screws with the provided Allen wrench. Replace the pole's top cap.

Task Lights will be shipped in separate carton(s), along with their associated hardware, parts and installation guide. Carefully un-pack the lights from the carton(s).



- **RISK OF ELECTRIC SHOCK – CONNECT THE TASK LIGHT (LUMINAIRE) TO A PROPERLY GROUNDED OUTLET ONLY.**
- **DO NOT ALLOW THE TASK LIGHT CORD OR COMBUSTIBLES SUCH AS PLASTIC, PAPER GOODS, AND SIMILAR MATERIALS TO COME IN CONTACT WITH THE LAMP, LAMP HOLDER AND REFLECTOR.**
- **WITH RESPECT TO THE COMMAND CONSOLE'S TASK LIGHT BRACKET ACCESSORY, THE ABOVE LISTED LUMINAIRES ARE INTENDED FOR USAGE ONLY AS INSTRUCTED BELOW. THEY ARE NOT INTENDED FOR ILLUMINATION OF AQUARIUMS OR FOR INSTALLATION IN PLASTIC CABINETS.**

PLACE ALL SEPARATELY PACKED ACCESSORY INSTRUCTIONS AND INSTALLATION GUIDES INTO THE COMPLETED CONSOLE SO THAT THEY WILL BE AVAILABLE TO THE END USER OF THE CONSOLE.



To attach a Trillium style light to the bracket:

1. Attach the task light support sleeve and two washers to the bracket with a ¼ x 1" Allen head screw and a ¼" lock nut.
2. The light's support stud can now be inserted into the sleeve. Follow the instructions provided with the Trillium light to complete the assembly.



To attach a Revo style light to the bracket:

1. Remove the (3) flat head screws from the Revo surface mount bracket to dis-assemble the light's cylindrical base.
2. Re-attach the base to the Console's Task Light Bracket with the (3) screws.
3. Follow the instructions provided with the Revo light to complete the assembly.

A. Grounding and bonding the console

NOTICE

GROUNDING OF THE CONSOLE TO THE BUILDING'S COMMON GROUNDING SYSTEM MUST BE DONE BY A LICENSED ELECTRICIAN.

Grounding of the console to the building's common grounding system is required. Grounding is made in accordance with UL 962 standards for household and commercial furnishings. The bonding connector shall be attached to any one of the (4) Protective Earth Terminals (PET) connection points in the console. The grounding connector must be attached to the enclosure's ground point as shown.

Protective Earth Terminals (PET) are labelled with proper symbol shown at right, and are the only terminals to which the protective earth ground connections shall be attached.



When grounding the console to the building common grounding, it is essential that the main protective ground is connected and secured to the terminal first with its own star washer and lock nut before any bonding connections are made on top as shown below.

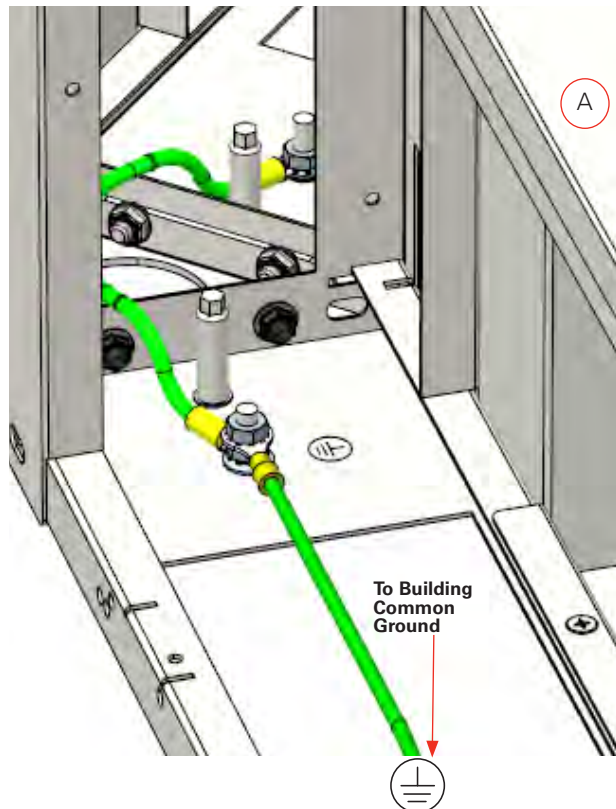

B. Plugging the console in

This product is rated for more than 15 amperes and is for use on a circuit having a nominal rating of 120 volts and is equipped with specific electrical plugs to permit connection to a proper electrical circuit. Make sure that the product is connected to outlets having the same configuration as the plugs. No adapter should be used with this product.

Once the console has been connected to the appropriate outlets, the power strips, lift motor system, and any electrical accessories plugged into the cabinet's power strips will be energized.

Hardware required



H x 8



S x 8

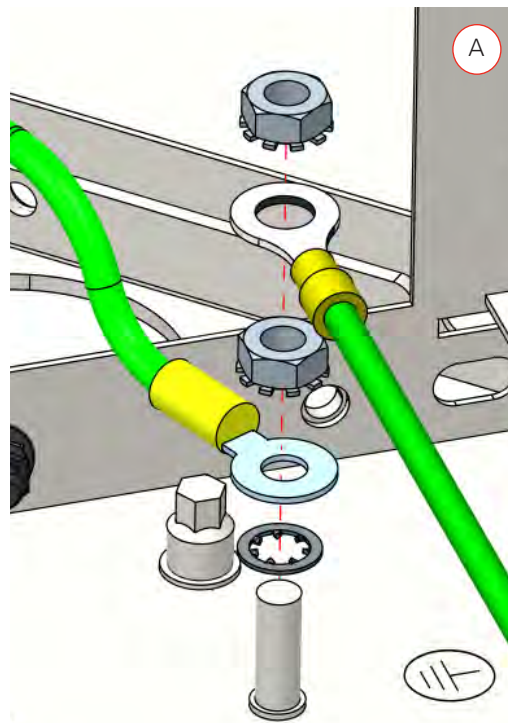

A. Cabling the console

All cables that originate from the desk top should enter the TechCurb for distribution to the power strips and (or) the base cabinets. Cables that are being routed to the base cabinets must run through either of the two cable chains.

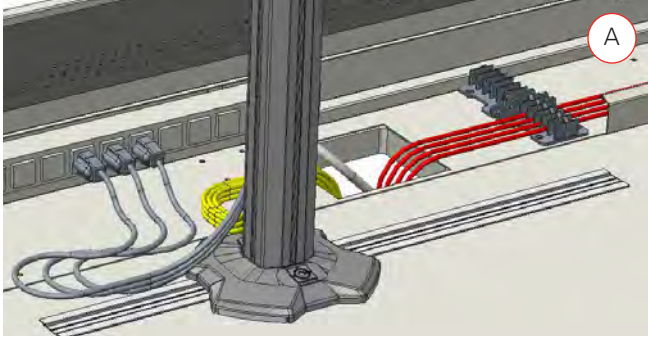

Upon exiting the base end of the cable chains, cables may be routed laterally through the base cabinet's inter-connected horizontal cable channel. The channel's covers may be hinged open for access, or completely lifted off and set aside.

Cables may enter the console through the bottom cable access holes or through the rear corner cable access holes.

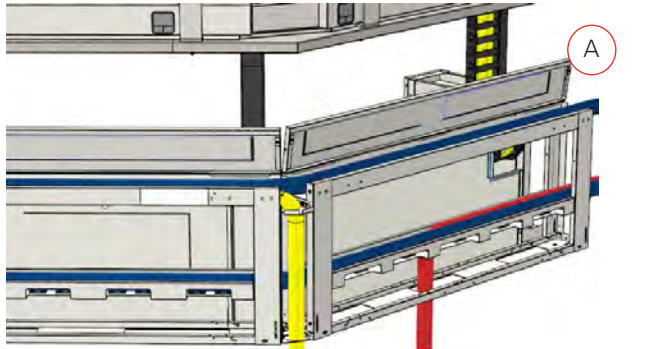

B. Operating the height adjustable worksurface

Your command console is equipped with a DP1CS control pad.

- Parallel up
- Parallel down
- Memory 1
- Memory 2
- Memory 3
- Store memory



Normal operation:

To run the desk up or down press the UP or DOWN arrow button (\wedge or \vee), and keep it pressed until the desk reaches the desired height. The display will count up or down while running, and after stopping it will continually show the current height of the desk.

As a safety precaution, your OnGuard Command Console is pre-programmed to "single reference" mode. In "single reference" mode, the controller requires the presence of four healthy lift

motors. In the event of a lift motor fault condition, the controller will disable the signal to the remaining motors, preventing the movement of the worksurface.

NOTICE

The console's lift motors have sensors that will detect an obstruction when moving. If the work-surface is jarred during operation or an obstruction is sensed, the worksurface will stop movement and automatically begin to move in the opposite direction.

Store a memory position:

The 4 small buttons are used for storing memory.

- Press the "S" button; the display will flash "S" for 2 seconds
- Within these two seconds press one of the small buttons with numbers "1", "2" or "3" and the position will be stored at this button.
- The panel will acknowledge the setting by showing "1", "2" or "3" in the display, depending on the chosen position

Memory Drive

Press and hold one of the memory buttons and the system will start driving to the pre-programmed memory position. Keep the button pushed until the position is reached.

Display Function

Shows the actual height either in inches or cm. The display also shows error codes.

Adjust the display to show the correct height:

It may be necessary to adjust the height display after the initial set up of the console. Simultaneously press the "UP" and "DOWN" arrow buttons (\wedge or \vee) and keep them pressed for 5 seconds. This allows the initial height to be re-set. Until the initial height is re-set, the display will show three minuses (- - -). Thereafter the display will revert to showing the height. The height can then be adjusted by pressing either \wedge or \vee until the correct height has been set. The system will return to normal operation (and give a short blink) after 5 seconds of inactivity on the buttons. The feature can be disabled via configuration after which pressing the \wedge and \vee buttons at the same time will be considered an illegal keypress.

Switch between cm and inches:

Your DP1CS control pad is pre-configured to display in inches. Switching between cm and inch can only be done via the DPF configurator.

Adjusting the light intensity of the LED display

Possible light settings are off, 6%, 12%, 19%, 25%, 37%, 50%, 75% and 100%.

The adjustment can only be done via the DPF configurator.

Adjusting the light timeout

Possible light timeouts are: 0-15 sec and off.

The adjustment can only be done via the DPF configurator.

Error code information

Possible error codes are shown below. The errors will only be displayed when a button is pressed. The display blinks while showing the error. E16 overrules any other error as the detection is registered only in the display and no message is sent to the control box.

E01 The console has an unknown position and needs to be initialized (See Section III.D.)

E02 Overload upwards has occurred

E03 Overload downwards has occurred

E16 Illegal keys pressed

Other diagnostic error codes may get displayed. When calling your customer service representative for technical assistance, please take note of all displayed error codes.

C. Using the personal environment system

Refer to the instructions provided with the personal environment system.

OnGuard System layouts

OnGuard consoles can be configured in multiple layout options by linking the consoles together or by way of various connector assemblies. The Connector options are shown in fig .

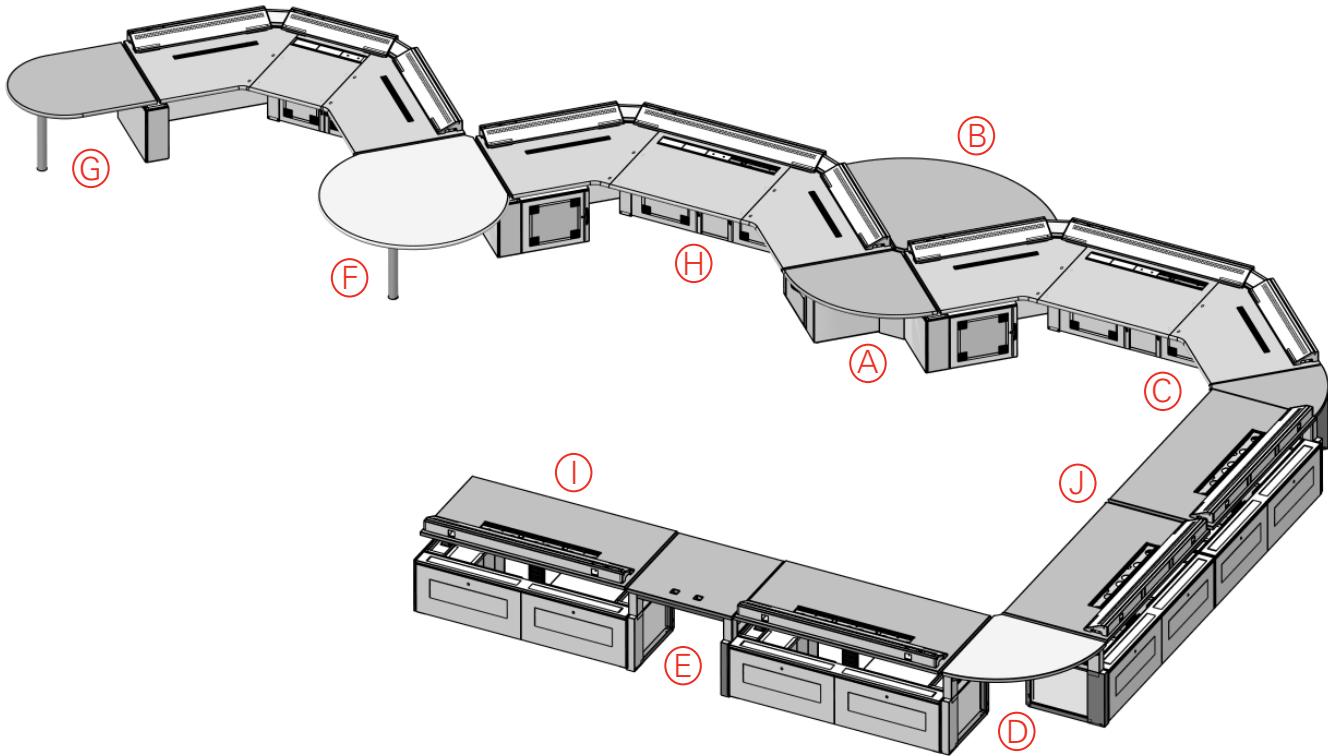

- A. Front Connector (90 degree), Curved Worksurface
- B. Rear Connector (90 degree), Curved Worksurface (Straight available)
- C. Corner Connector (45 degree), Curved Worksurface
- D. Corner Connector (90 degree), Curved Worksurface
- E. Linear Connector, Straight Worksurface {24",30", and 36"}
- F. Front Connector (90 degree), Teardrop Worksurface (Peninsula available)
- G. End Peninsula Worksurface
- H. Corner Console
- I. Linear Console
- J. Directly Connected Consoles

NOTICE

To avoid damage to consoles or connectors:

- Assemble each main work station module completely before working on adjacent modules.
- A fully assembled work station module can be very heavy and difficult to move. Also, moving a fully assembled module can induce stresses in the module that may affect functionality of the motorized height adjustable work surfaces. Therefore, it is recommended that each work station module be fully assembled in its final intended position.
- Adjacent work station modules should be securely attached to each other before moving on to additional modules.

OnGuard system layouts corner console

A. Prepare consoles for system layout

1. Unlock and remove rear panels from each of the base cabinets. To remove a panel, open rear cable channel cover, and pull panel off from top edge.
2. Unlock and remove the end panels from the left and right base cabinets by lifting up on the panels.
3. Before connecting multiple consoles, be sure to locate consoles as close to final position.
4. Adjust leveling feet to ensure top of base structure is level and aligned with connectors or adjacent consoles.

NOTICE

ONCE COMPLETELY ASSEMBLED, THE CONSOLES WILL BE HEAVY AND DIFFICULT TO MOVE, PARTICULARLY ON CARPETING.

DO NOT OMIT ANY SCREWS. ALL SCREWS ARE REQUIRED TO ENSURE THAT CONSOLES REMAIN STABLE WHEN WORK SURFACE IS ELEVATED TO HIGHEST POSITION.

ALL LEVELING FEET OF BASE STRUCTURE MUST BE IN DIRECT CONTACT WITH THE FLOOR TO ENSURE CONSOLE REMAINS STABLE WHEN WORK SURFACE IS ELEVATED TO ITS HIGHEST POSITION.

IMPROPER ADJUSTMENT OF THE LEVELERS MAY CAUSE THE BASE CABINETS TO TWIST, RESULTING IN MIS-ALIGNMENT OF FRONT DOORS AND DRAWERS. ENSURE THAT LEVELERS ARE ADJUSTED IN SUCH A WAY AS TO ENSURE PROPER DOOR AND DRAWER ALIGNMENT.

⚠ CAUTION

TO ENSURE TO ENSURE ELECTRICAL GROUND CONTINUITY THROUGH THE ENTIRE SYSTEM, THE GROUND CONNECTIONS AS DESCRIBED ABOVE IN SECTION V, MUST BE MADE, BETWEEN CONSOLES.

SYSTEM CAN HAVE MULTIPLE CORDS FROM POWER STRIPS, CORDS CAN NOT BE ROUTED THROUGH MULTIPLE CONSOLE UNITS.

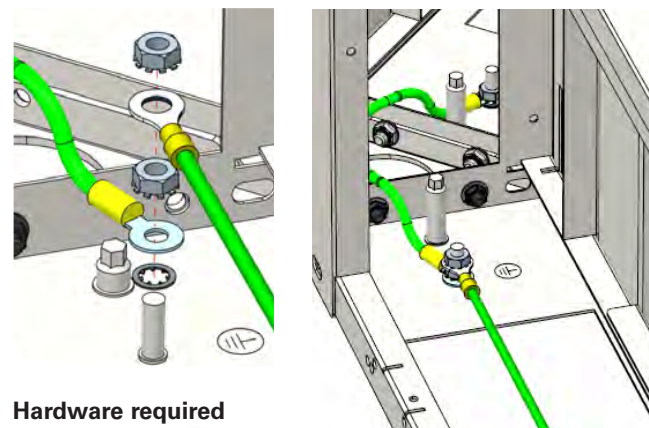
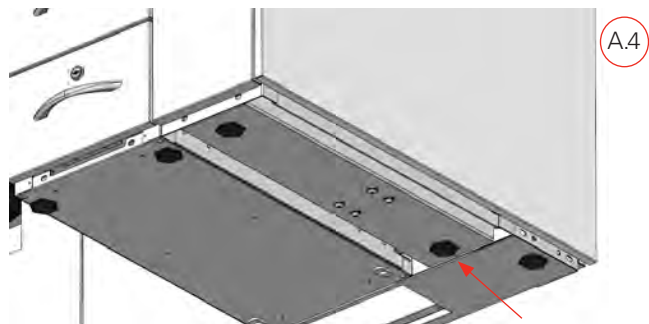
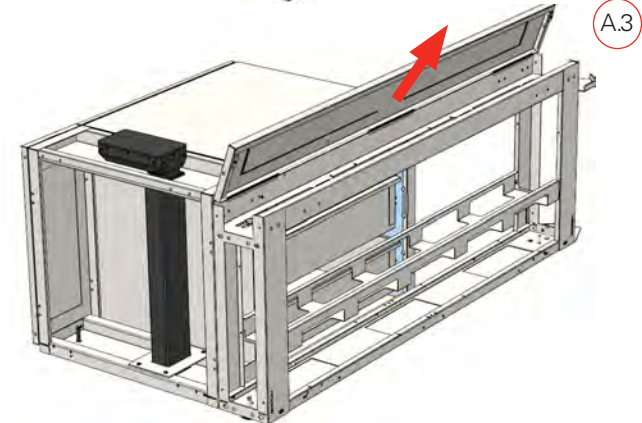
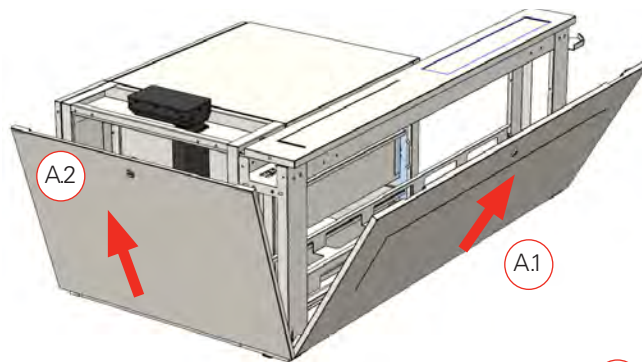

Hardware required



To Building
Common
Ground



Front connector (90 degree)

B. Assemble consoles with front connector

1. Position 2 consoles (Corner or Linear) close to final location and Connect to 90 degree wedge connector bracket (a.)
2. Secure with (8) 1/4" x 1/2" self-threading hex head screws (A)(4) screws for each console base cabinet). Secure from inside console core.
3. Assemble worksurface support brackets (b.) (4X) with (8) 1/4" x 1/2" self-threading hex head screws (A) (4 each bracket).
4. Align mounting holes in worksurface (c) and support brackets and attach with 3/4" Phillips head wood screws (E) (16x)
5. Attach center panel (d) to wedge bracket (magnets will hold in place).
6. Install interior size side panels (e), included with Connector assembly. Hook at bottom and rotate up (magnets will secure at top). Lock if required.

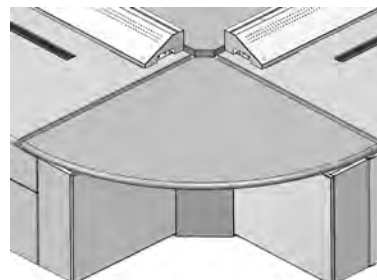
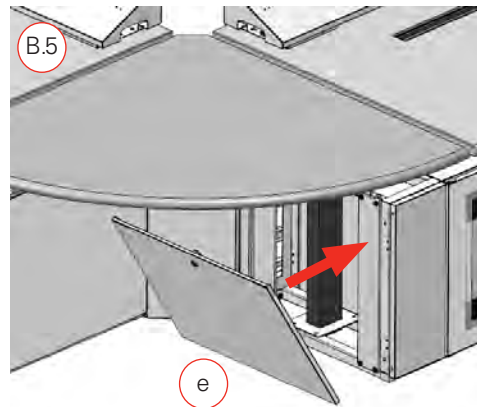
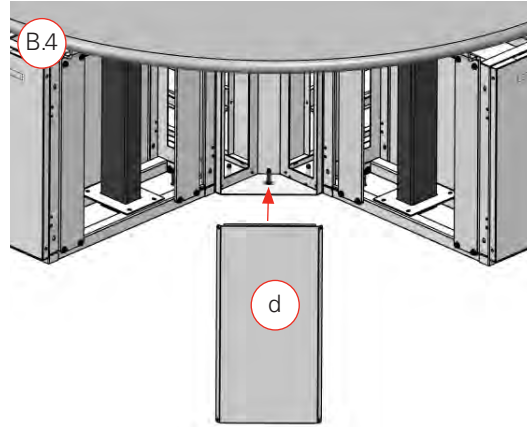
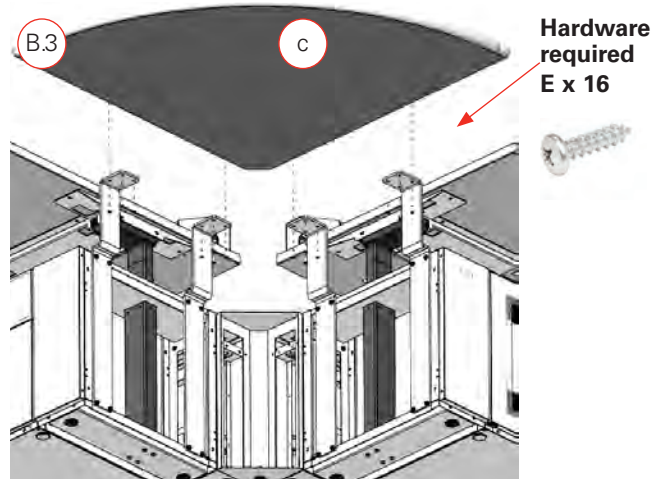
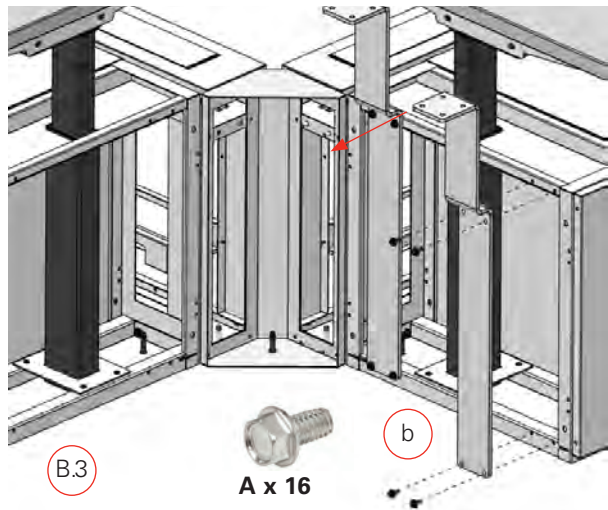
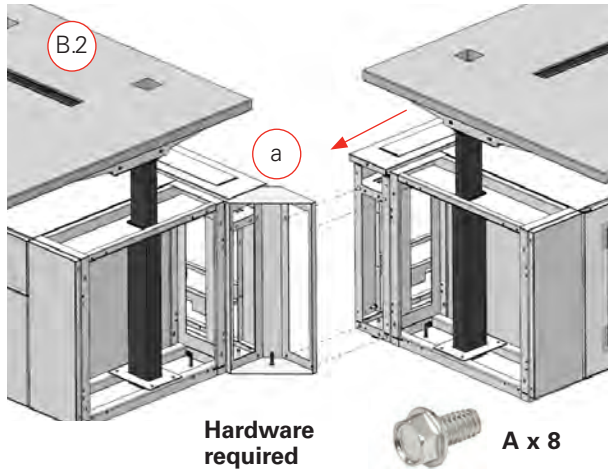

Front connector (90 degree)

C. Assemble consoles with front teardrop or peninsula connector

1. Position 2 consoles (corner or linear) close to final location and Connect to 90 degree wedge connector bracket (a.)
2. Secure with (8) 1/4" x 1/2" self-threading hex head screws (A) (4) screws for each console base cabinet. Secure from inside console core.
3. Assemble worksurface support brackets (b.) (4X) with (8) 1/4" x 1/2" self-threading hex head screws (A) (4 each bracket).
4. Align mounting holes in worksurface (c) and support brackets and attach with 3/4" Phillips head wood screws (E) (16x). Attach front support leg (d) use same screws (6x).
5. Attach center panel (d) to wedge bracket (magnets will hold in place).
6. Install interior size side panels (e), included with connector assembly. Hook at bottom and rotate up (magnets will secure at top). Lock if required.

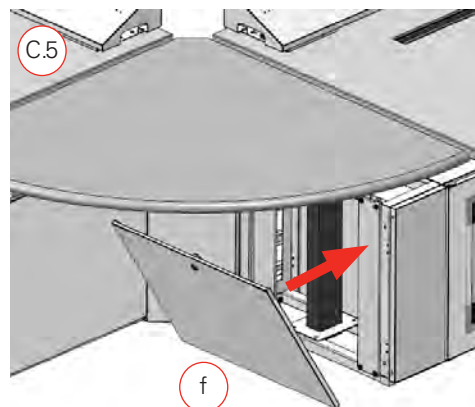
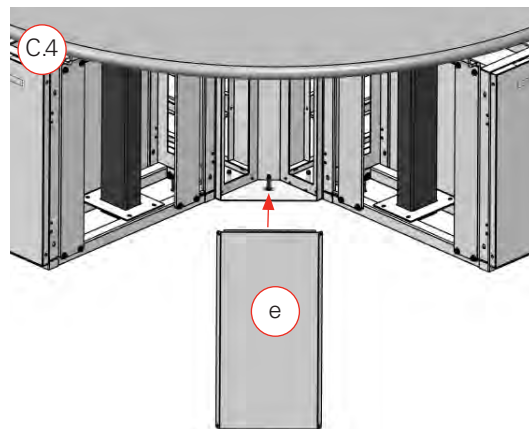
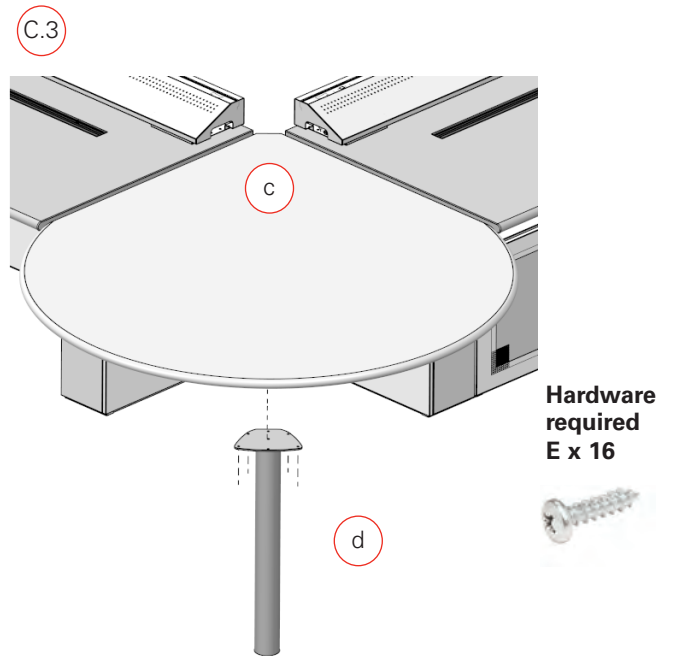
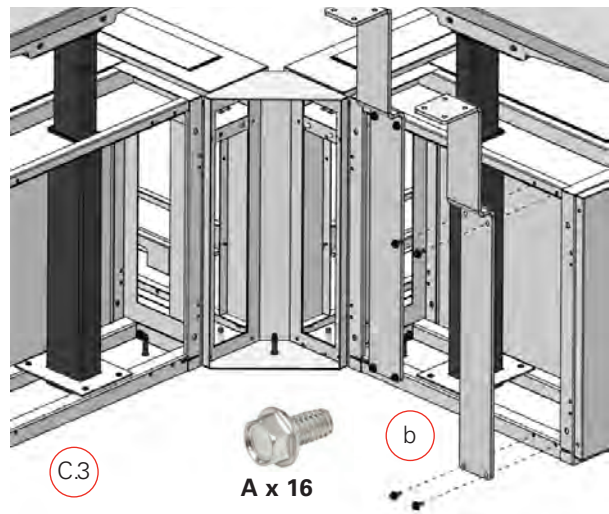
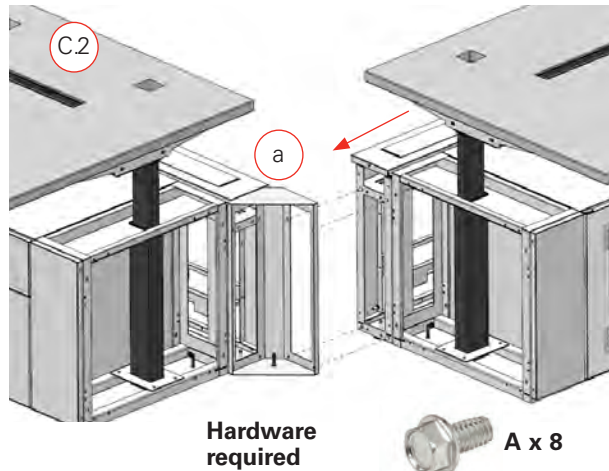

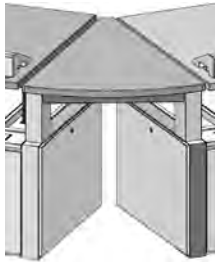

45 Degree

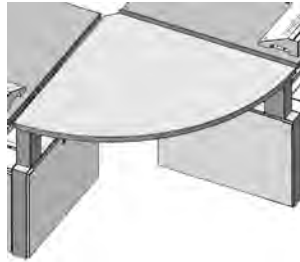

90 Degree

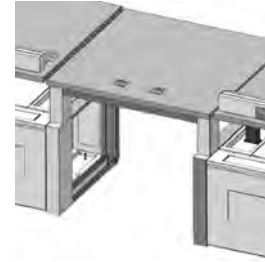

Linear 24", 30", 36"

Connector (45 degree)

D. Assemble consoles with 45, 90 degree and linear connectors

1. Position 2 consoles (corner or linear) close to final location
2. Attach to both console ends, a left and right hand support frame (a). Secure with (8) 1/4" x 1/2" self-threading hex head screws (A) (6) screws for each console base cabinet from inside console core at back and through front clearance holes.
3. Attach cable channel (b) to worksurface (c) with 3/4" Phillips head wood screws (E) (6x).
4. Align mounting holes in worksurface (c) and support brackets and attach with 3/4" Phillips head wood screws (E) (12x).
5. Install interior size side panels (e), included with connector assembly. Hook at bottom and rotate up (magnets will secure at top). Lock if required.

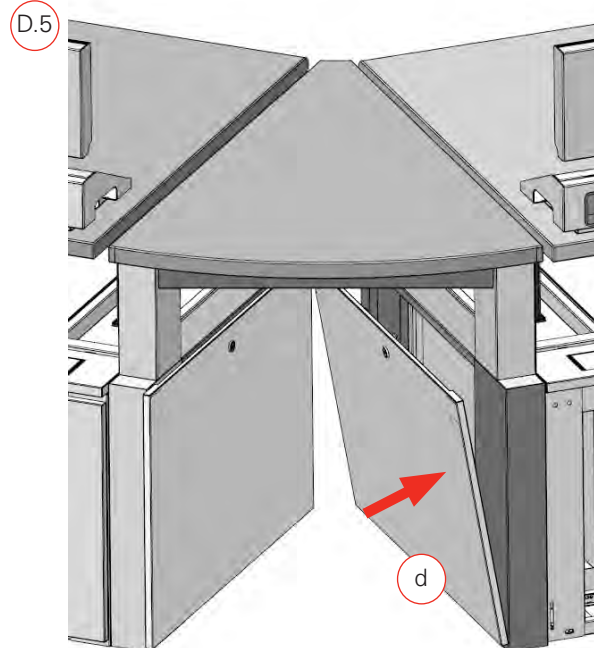
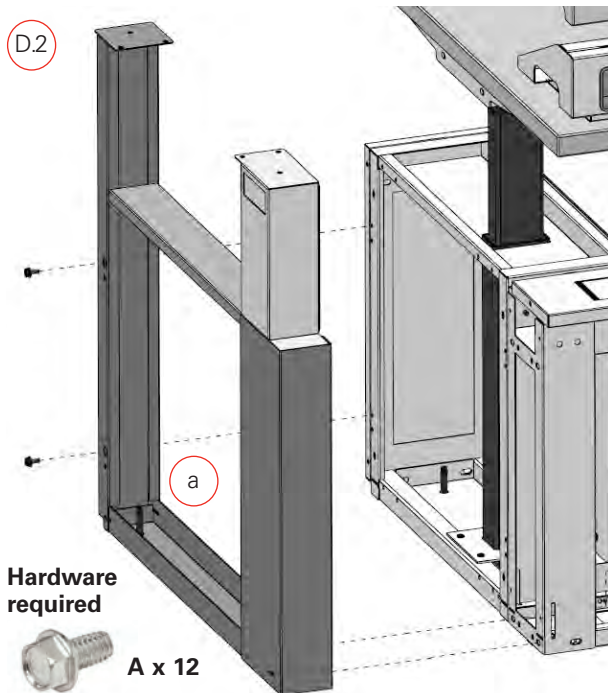
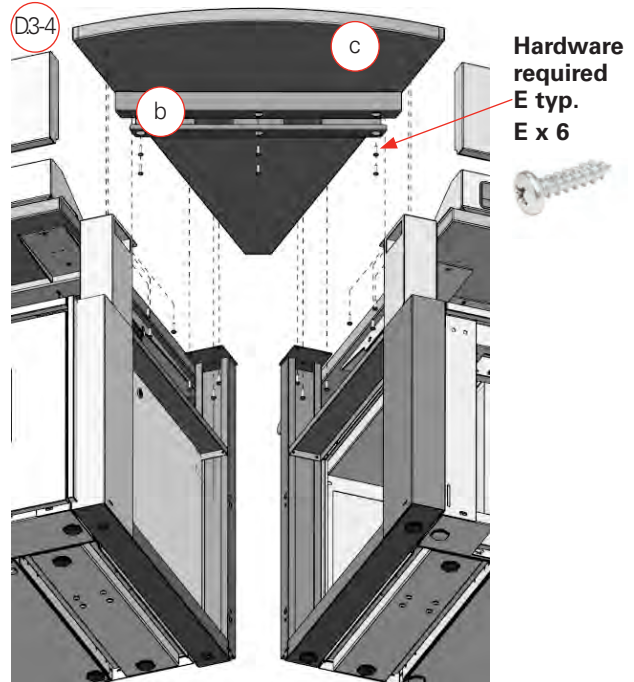

Rear connector (90 degree)

E. Assemble rear connector worksurface

1. To be used in conjunction with assembled 90 degree front wedge connector (a.)
2. Assemble worksurface support brackets (b.) (4X) with (8) 1/4" x 1/2" self-threading hex head screws (A)(4 each bracket).
3. Align mounting holes in worksurface (c) and support brackets and attach with 3/4" Phillips head wood screws (E) (16x)
4. Install Rear panels (e), Hook at bottom and rotate up (magnets will secure at top). Lock if required

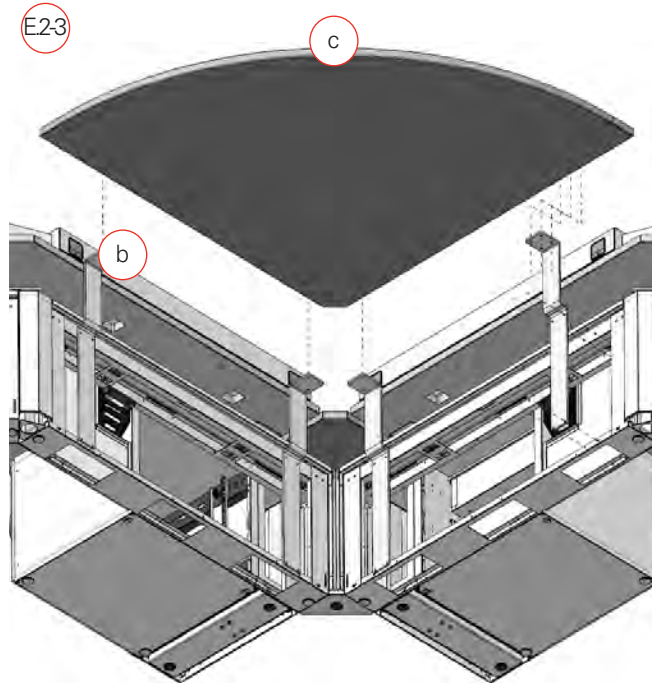
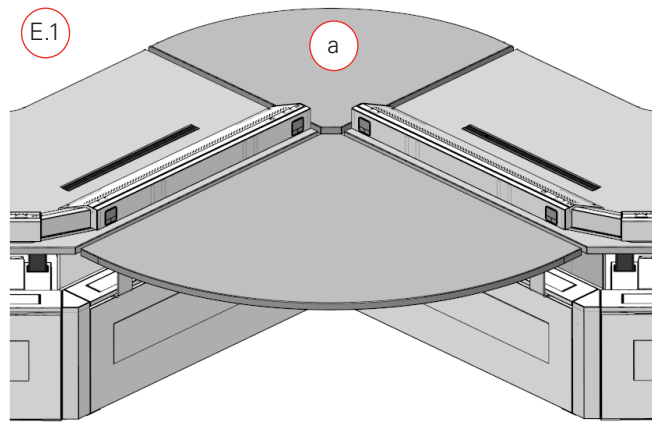

Hardware
required
E Typ.



A Typ.

End peninsula

F. Assemble end peninsula to end of console

1. Assemble worksurface support brackets (b.) (2X) with (8) 1/4" x 1/2" self-threading hex head screws (A)(4 each bracket).
3. Align mounting holes in worksurface (c) and support brackets and attach with 3/4" Phillips head wood screws (E) (16x). Attach front support leg (d) use same screws (6x)
4. Install side panels (e), Hook at bottom and rotate up (magnets will secure at top). Lock if required.

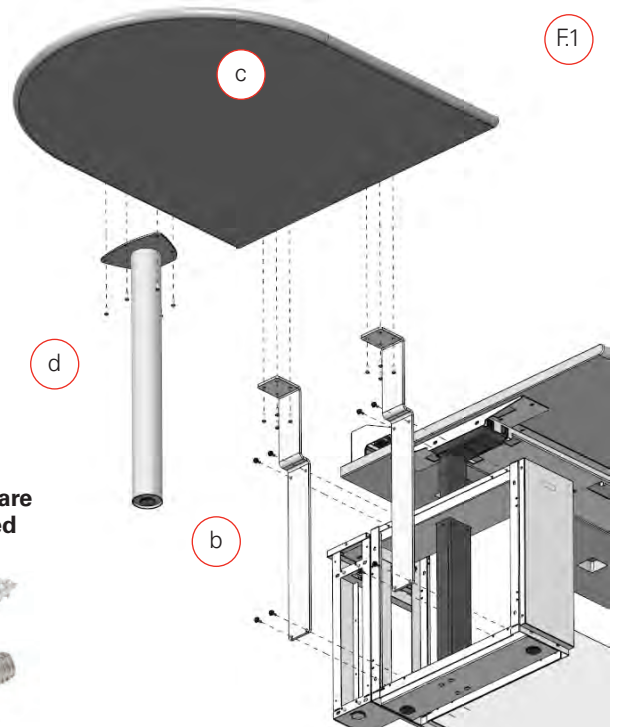

F.4

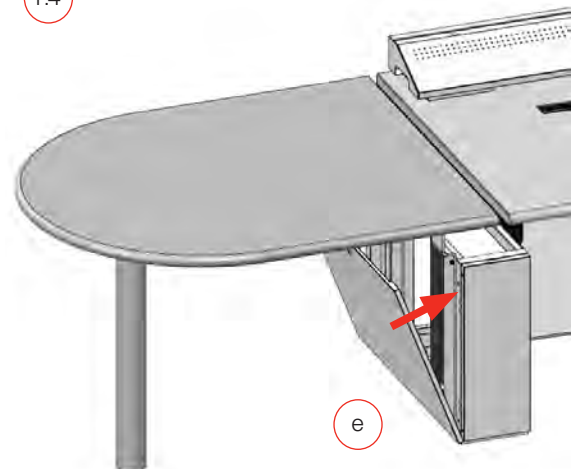

Rack mount tower

G. Assemble rack mount tower to layout end.

1. Position tower at end of console or configuration layout, raise adjacent worksurface up to highest position.
2. Align and level consoles so mounting holes match up at the rear and front of the units.
3. Secure with 1/4" x 1/2" hex head self-threading hex head screw (A) 4X at front and rear of console, inside core channels, top and bottom.
4. Lower worksurface, and install inside filler panel and end panel as shown. Replace all remaining panels, front and back as required.

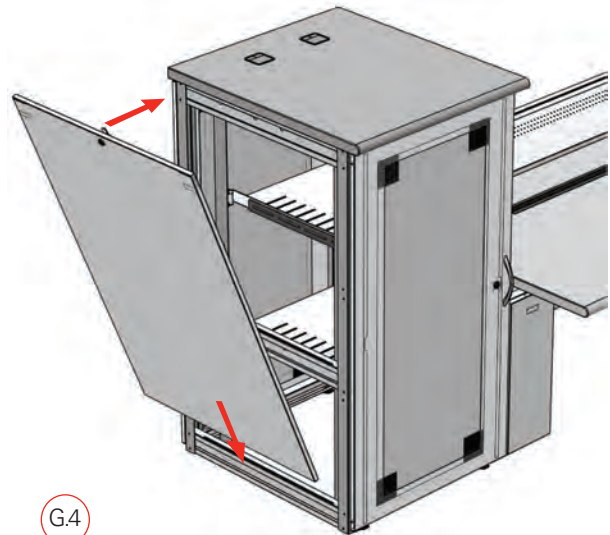
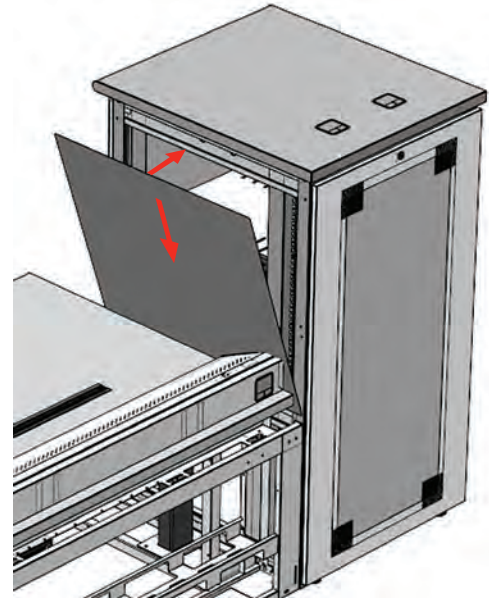
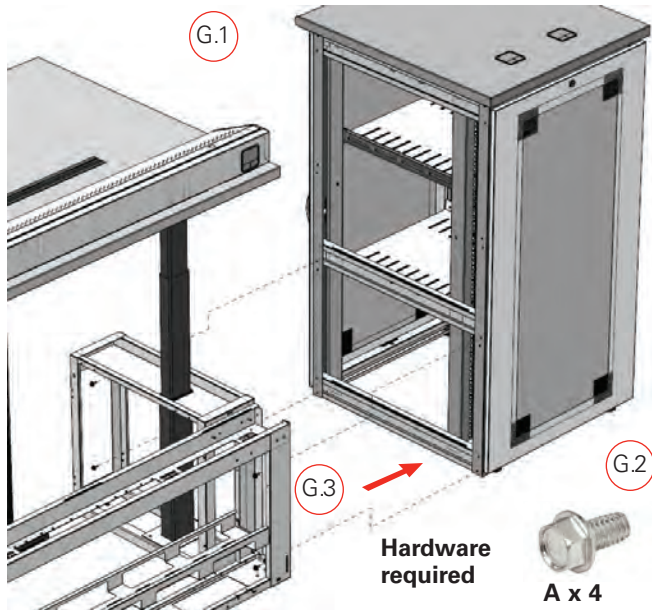

H. Assemble rack mount tower in between consoles.

1. Assemble tower same as G.3, both ends, secure with 1/4" x 1/2" hex head self-threading hex head screw (A) 8X at front and rear of consoles, inside core channels, top and bottom.

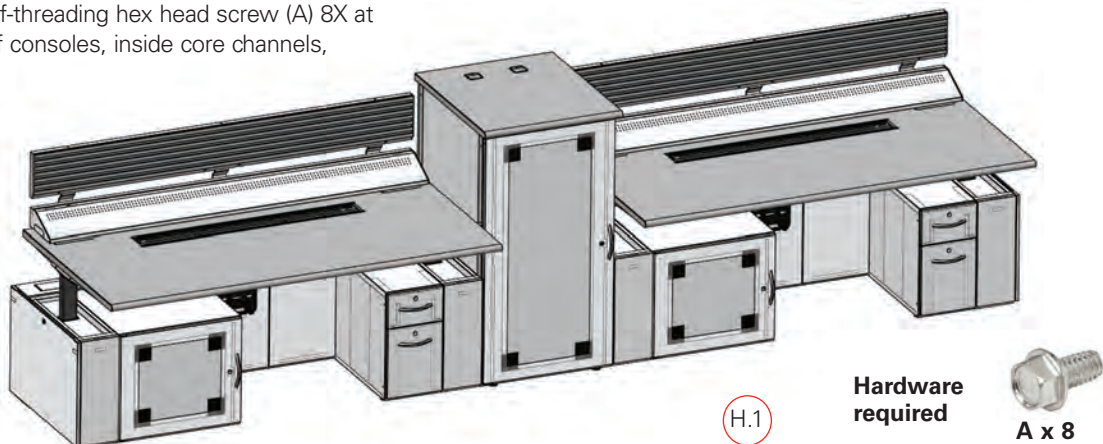

Direct console to console connection

I. Assemble multiple consoles together

1. Position 2 consoles (corner or linear) close to final location. Remove front panels on Lift box front (2X)
2. Align and level consoles so mounting holes match up at the rear and front of the units.
3. Secure with 1/4" x 1/2" hex head self-threading hex head screw (A) and 1/4" lock nut (H) 4X at rear of consoles, inside core channels.
4. Secure using 1/4" x 1/2" hex head self-threading hex head screw (A) 2X at front. Replace all panels, front and back.

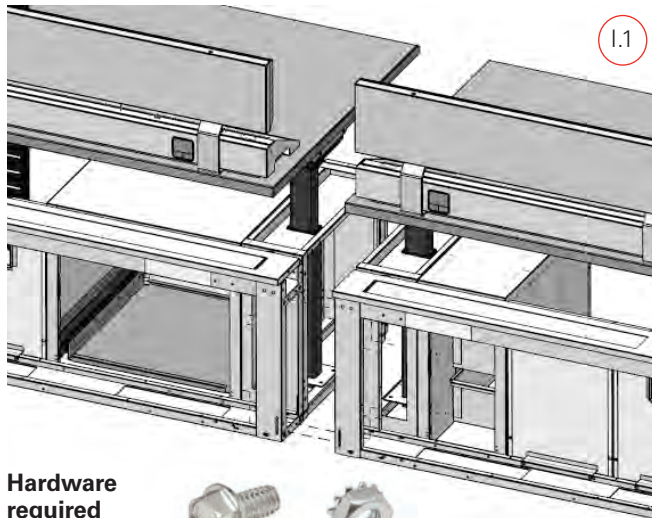

Hardware required



A x 4



H x 4

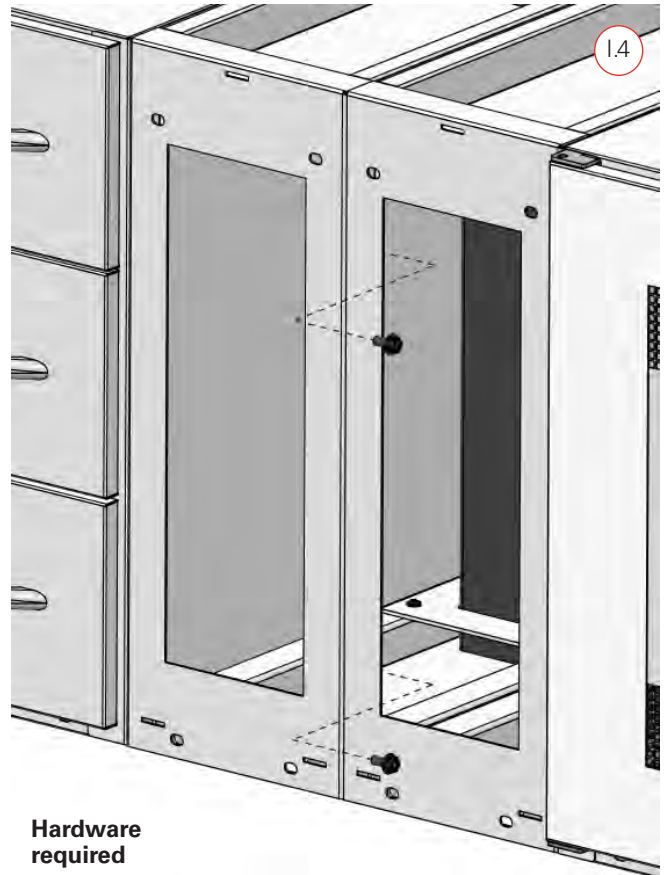

Hardware required



A x 2

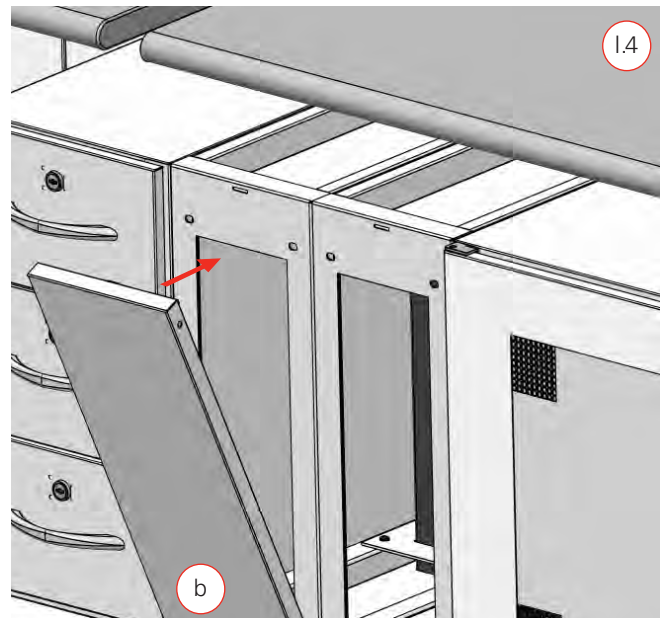
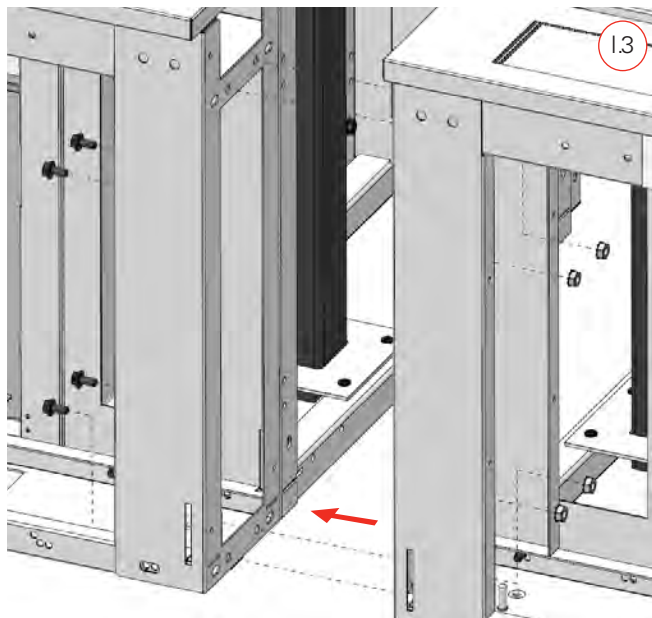



THIS CONSOLE DOES NOT HAVE ANY USER SERVICEABLE PARTS. ALL SERVICING EXCEPT CLEANING AND PERIODIC VISUAL INSPECTION SHALL BE PERFORMED BY AN EATON AUTHORIZED SERVICE REPRESENTATIVE.

THIS CONSOLE'S ELECTRICAL LIFT SYSTEM HAS DOUBLE-INSULATED COMPONENTS. IN A DOUBLE-INSULATED PRODUCT, TWO SYSTEMS OF INSULATING ARE PROVIDED INSTEAD OF GROUNDING. NO GROUNDING MEANS ARE PROVIDED ON A DOUBLE-INSULATED PRODUCT. SERVICING A DOUBLE-INSULATED PRODUCT REQUIRES EXTREME CARE AND KNOWLEDGE OF THE SYSTEM AND IS TO BE DONE ONLY BY QUALIFIED SERVICE PERSONNEL. REPLACEMENT PARTS FOR A DOUBLE-INSULATED PRODUCT MUST BE IDENTICAL TO THE PARTS THEY REPLACE. A DOUBLE-INSULATED PRODUCT IS MARKED WITH THE WORDS "DOUBLE INSULATION" OR "DOUBLE INSULATED". THE SYMBOL (SQUARE WITHIN A SQUARE) SHOWN HERE; IS ALSO ABLE TO BE MARKED ON THE PRODUCT



Care and cleaning

If during operation, the product makes unusual noise or odors, immediately unplug the cabinet from the receptacle(s). Contact technical assistance for help using the contact information in section 1 of this installation manual.

Every six months

Visually inspect the product looking for loose fasteners and loose or damaged parts. Inspect all wires and cables looking for loose connections and pinched or frayed wires.

Laminated worksurface care and cleaning

Avoid placing hot items and heat-producing appliances on the worksurface. When set directly upon the worksurface, hot objects can damage the laminated surface.

To clean the surface, use a damp cloth or sponge and a mild soap or detergent. Difficult stains such as coffee or tea can be removed using a mild household/industrial cleaner and a soft bristled brush, repeating as necessary. If a stain persists, use a paste of baking soda and water and apply with a soft bristled brush. Light scrubbing for 10 to 20 strokes should remove most stains. Excessive scrubbing or exerting too much force could damage the decorative surface.

Recommended cleaners for work surfaces

Windex® Glass Plus® Lestoil® Grease Relief® Dawn® Fantastik® Favor® Pledge® Mr. Clean® TOP JOB® Formula 409® Clorox® Isopropyl Alcohol (Isopropanol), or similar standard industrial cleaners.



PROLONGED EXPOSURE TO BLEACH OR CLEANERS CONTAINING BLEACH WILL CAUSE DISCOLORATION.

Painted surface cleaning

Wash your painted surfaces at least once every six months.

1. Combine 1 gallon of water with one cup of a neutral detergent in a bucket.
2. Wipe the painted surfaces with a clean rag dampened with the cleaning solution. Use gentle repetitive pressure to remove built up grime. Avoid excessive scrubbing. Do not use abrasive products or scrubbing pads.
3. Rinse the painted surfaces with an un-used clean rag, dampened with clean, clear water.
4. Finally, wipe the surfaces with a dry clean rag to prevent streaking and spotting.

Eaton
1000 Eaton Boulevard
Cleveland, OH 44122
United States
Eaton.com

© 2019 Eaton
All Rights Reserved
Printed in USA
Publication No. IB210003EN
November 2019

