



*Powering Business Worldwide*

Aerospace Group  
Conveyance Systems Division

Carter® Brand Ground Fueling Equipment

**SM64019**

October 2010

Applicable additional manuals:

None

## **Maintenance Manual**

---

## **Non-Valved Unisex Coupling**

---

**Model 64019**

**Model 64319**

TABLE OF CONTENTS

	Page
1.0 INTRODUCTION .....	3
2.0 EQUIPMENT DESCRIPTION .....	3
3.0 TABLE OF OPTIONS AND ORDERING INFORMATION .....	3
4.0 DISASSEMBLY .....	4
5.0 INSPECTION.....	5
6.0 REASSEMBLY .....	5
7.0 TEST .....	6
FIGURE 1 - BASIC UNIT BREAKDOWN.....	9
FIGURE 2 - INLET OPTIONS AVAILABLE.....	10

## Maintenance, Overhaul & Test Instructions Model 64019 and Model 64319 Non-Valved Unisex Couplings

### 1.0 INTRODUCTION

This manual furnishes detailed instructions covering the maintenance and overhaul of Eaton's Carter brand Model 64019 and Model 64319

Non-Valved Unisex Couplings and the various options listed in Section 3.0.

### 2.0 EQUIPMENT DESCRIPTION

Model 64019 Model 64319 non-valved unisex couplings are 2 inch hose couplings that are universally connectable to either another model 64019 or 64319 non-valved unisex coupling, to other derivatives of Eaton's Carter brand family of unisex couplings or to similar couplings made by Eaton's Aeroquip brand. The units are qualified in accordance with A-A-59377, Class A (which supersedes MIL-C-53071). Other Eaton units to

which the 64019 and 64020 will mate are listed in Section 3.0.

The basic non-valved coupling can be procured under the part number 64019 or 64319 with various options that determine the desired inlet or hose mounting configuration. The table in Paragraph 3.0 and the figures at the end of this manual include the various options available.

### 3.0 TABLE OF OPTIONS AND ORDERING INFORMATION

Model 64019 and Model 64319 are available with various inlet or hose mounting configurations as described in the tables below. The units are

available in two colors to meet the customer's requirements, tan (standard) and green (option V).

#### OPTIONS TO BE ADDED TO 64019 NON-VALVED UNISEX COUPLING

OPTION LETTER	DESCRIPTION	OPTION LETTER	DESCRIPTION
A	Adds 40-mesh strainer	M	Adds 3" male BSPP Inlet
B	Adds 60-mesh strainer	N	Adds D-1/D-2 Inlet Flange
C	Adds 100-mesh strainer	P	Adds 2" female BSPP Inlet
D	Adds 1-7/8" UNC-2A male thread inlet	Q	Dust cap/plug, camlock type
E	Adds 2" hose barb Inlet	R	Adds 1-1/2" female NPT Inlet
F	Adds 2" male camlock Inlet	S	Adds 1" male NPT Inlet
G	Adds 1-1/2" male NPT Inlet	T	Adds flanged inlet per MS33786-32
J	Adds 2" male NPT Inlet	U	Adds 1-1/2" male BSPP inlet
K	Adds 2" male BSPP Inlet	V	Changes exterior color to green
L	Adds 3" male NPT Inlet	Z	Changes mating lugs to stainless steel

Note: One or more of the above options letters must be included with the basic part number 64019 to receive a completed unit.

Example: 64019F - Valved unisex coupling, meets tan color requirements, with 2" male camlock inlet fitting.  
64019JV - Valved unisex coupling, meets green color requirements, with 2" male NPT inlet fitting.

**OPTIONS TO BE ADDED TO 64319 NON-VALVED UNISEX COUPLING**

<b>OPTION LETTER</b>	<b>DESCRIPTION</b>	<b>OPTION LETTER</b>	<b>DESCRIPTION</b>
A	Adds 40-mesh strainer	31	Adds 1-1/2" female NPT Inlet
B	Adds 60-mesh strainer	32	Adds 2" female NPT Inlet
C	Adds 100-mesh strainer	33	Adds 2-1/2" female NPT Inlet
Q	Dust cap/plug, camlock type	40	Adds 1-1/2" male BSPP Inlet
V	Changes exterior color to green	41	Adds 2" male BSPP Inlet
Z	Changes mating lugs to stainless steel	42	Adds 3 inch BSPP male adapter
1	With ball joint adapter	43	Adds 1-7/8-16UN-2A male adapter (adapts to GFA nozzle)
2	With flange inlet, non-swivel	50	Adds 1-1/2" female BSPP Inlet
3	With 1-1/2 inch NPT male inlet, non-swivel	51	Adds 2" female BSPP Inlet
4	With 2 inch NPT male inlet, non-swivel	52	Adds 2-1/2" female BSPP Inlet
5	With 1-1/2 inch BSPP male inlet, non-swivel	53	Adds female, 37° flared inlet, size -32
20	Adds 1" male NPT Inlet	70	Adds 2" camlock, female
21	Adds 1-1/2" male NPT Inlet	80	Adds 1-1/2" hose barb
22	Adds 2" male NPT Inlet	90	Adds D-1/D-2 flange inlet
23	Adds 3 inch NPT male adapter	91	Adds flanged inlet per MS33786-32

Note: One or more of the above options letters must be included with the basic part number 64319 to receive a completed unit.

Example: 64319B61 - Valved unisex coupling, meets tan color requirements, with 60-mesh strainer and 2" male camlock inlet fitting  
 64319V22 - Valved unisex coupling, meets green color requirements, with 2" male NPT inlet fitting

**MULTIPLE VALVED UNISEX COUPLING UNITS****Using basic 64019 Couplings**

<b>UNITS CONFIGURATION</b>	<b>PART NUMBER (Tan Color)</b>	<b>PART NUMBER (Green Color)</b>
Tee - three unisex couplings	64022E	64022EV
Elbow - two unisex couplings	64023E	64023EV
"Y" - three unisex couplings	64029E	64029EV
Cross - four unisex couplings	64030E	64030EV

Use the information in this manual to repair any of the basic couplings used on the above multiple units. The housings are not expected to be in need of repair. If there is a problem with one of the housings, contact Eaton for more information.

**4.0 DISASSEMBLY**

4.1 **Note** – On early models the screen option was only available on option N. It was trapped between the flange of option N and the housing. This paragraph applies only to those units.

If option N is being worked on, remove Screen (13) from unit's inlet and set aside. Remove the O-ring (12) and discard. Mounting Bolts (9), Washers (10) and Nuts (11) should be set aside for later reuse.

If another option is to be serviced move on to paragraph 4.2.

4.2 Remove Screw (1) using a torque wrench, checking the running torque. If the running torque is less than 3.5 in-lb. discard Screw (1). Note: Screw (1) is self-locking and is designed to be reused several times before replacement is necessary. If a torque wrench is not used to remove it, Screw (1) should be replaced. Remove and discard packing (2). Holding the unit over a suitable container to collect the Balls (3) in the swivel joint, with the screw hole toward the container, rotate the inlet fitting to allow the Balls (3) to fall into the container. There should be 41 Balls (3). When all 41 Balls (3) have been

- collected pull the Inlet (4) from the main unit. Remove and discard Packing (14). Set the Inlet (4), (5), (6), (7) or (8) aside for later use.
- 4.3 Remove Spring (15) and Seal (16).
  - 4.4 If the interlock pin mechanism is working properly there is no need to remove Ring (17), Pin (18) or Spring (19). If it is to be replaced remove these parts.
  - 4.5 If the Dust Cap (25) or the Cable (28) is to be replaced cut the cable to remove. The Cable (28) can also be removed from Ring (17) without cutting by rotating the loop through the split portion of the Ring (17).
- 4.6 Remove the Bumper (20) only if replacement is needed or if it is necessary to replace the Lugs (22) or (23).
  - 4.7 Remove Screw (21) to replace Lugs (22) and/or (23).
  - 4.8 Do not try to disassemble the Body (29) to remove the spring loaded ball permanently affixed in the face of the unit. If the ball is damaged, replacement of the Body (29) will be necessary.

5.0 **INSPECTION**

It is recommended that O-ring (12) (if present), Packings (2) and (14) and Seals (16) and (26) be discarded and replaced at each overhaul.

Inspect all metal parts for dings, gouges, abrasions, etc. Use 320 grit paper to smooth and remove sharp edges. Replace any part with damage exceeding 15% of local wall thickness. Use alodine 1200 to touch up bared aluminum.

Inspect the Bumper (20) for evidence of cracking or wear. Replace as necessary.

Pull Ring (17) to its fully extended position and release. The Pin (18) should fully retract and extend promptly. Clean parts and replace Spring (19) as needed.

Check Lugs (22) and (23) to assure that they are not loose. If loose, remove Bumper (20) to check the tightness of the Screws (21). Screws (21) should be tightened to 6 in-lb. **Note** – If the lugs are to be replaced be sure to replace them with like items, that is if Option Z is present

replace the lugs with the proper stainless steel lugs.

Count the Balls (3) to make sure that all 41 are present.

Check the hole in the face of the unit adjacent to the Pin (18) to be sure it is clear and free of contamination.

Check the groove (round bottom) in the Inlet (4 through 7) for burrs on the corners. If groove is worn such that burrs exist, use 320 grit paper to smooth and remove sharp edges. Burrs will make it difficult to re-install the part.

Inspect the Dust Cap (25) for soundness and completeness. If cracked or broken, replace.

Inspect the small spring loaded ball located in the face of the unit. Push the ball in and be sure that it pops back into place. The purpose of this ball is to provide electrical continuity between mating units.

6.0 **REASSEMBLY**

Reassemble the parts in the reverse order of disassembly noting the following:

- 6.1 Make certain all components are clean and free from oil, grease, or any other corrosion resistant compound on all interior or exterior surfaces. Wash all parts with cleaning solvent, Federal Specification P-D-680, and dry thoroughly with a clean, lint-free cloth or compressed air.

**WARNING**  
 Use cleaning solvent in a well-ventilated area. Avoid breathing of fumes and excessive solvent contact with skin. Keep away from open flame.

- 6.2 Install the Seal (26) in Dust Cap (25) using a finger to be sure that the seal is properly seated

in its groove. This Seal (26) and Seal (16) are identical. (Seal (26) is also interchangeable with the same type of part made for Eaton's Aeroquip brand of Unisex Couplings).

- 6.3 If the Cable (28) was cut to remove it from the Dust Cap (25), rebuild it by looping one end of the Cable (28) (approximately 18" long before assembly) through the hole in the Dust Cap (25). Make a loop approximately one inch long. Retain the loose end of the Cable (28) with Sleeve (27). Crush the Sleeve (27) to retain the Cable (28) using a pair of vise grips or heavy battery pliers. Thread the other end of the Cable (28) through the Ring (17), make a one inch loop and secure it with another Sleeve (27) affixing it as above.

- 6.4 If removed, drop the Spring (19) into the hole in the face of the unit. Insert Pin (18) and thread the Ring (17) through the hole in the Pin (18) to retain.
- 6.5 If removed during disassembly, install Lugs (22 and 23) in their proper positions. Match the holes in the Lugs (22 and 23) with the hole pattern in the Body (29). Tighten Screws (21) to 6 in-lb. to retain.
- 6.6 Install Bumper (20) onto Body (29) such that the thin lip seal end is facing away from the unit.
- 6.7 Install the Seal (16) into the groove in the face of the Body (29) making sure that its outer face is smooth and free of any wrinkles.
- 6.8 Spring (15) is inserted into the groove within the larger opening of the Body (29). This spring is used to assure electrical continuity between the Body (29) and the Inlet (4 thru 7).
- 6.9 The Inlet (4 thru 7) has various hose connections on one end and the other end contains two grooves. The groove (rounded bottom) nearest the end is for the ball race connection. The second groove (square bottom) is where Packing (14) is to be installed. Lubricate the Packing (14) with a light coat of petrolatum, Federal Specification VV-P-236.
- 6.10 Press Inlet (4 thru 7) into Body (29) to line up the groove in the Inlet (4 thru 7) and the groove in the Body (29). **DO NOT** use any form of grease on Balls (3). Insert the correct number of Balls (3) in the hole of the Body (29) to retain the joint together. Insert Screw (1) and Packing (2) into hole and tighten to 25 in-lb.

## 7.0 TEST

7.1 The following test procedures will be accomplished after overhaul:

### 7.2 Test conditions

Test media shall be JP-8 MIL-T-83133, Jet A, odorless kerosene or Stoddard type solvent MIL-PRF-7024E Type II.

### 7.3 Functional Test

7.3.1 Using the test unit and a similar unisex coupling make sure that they will connect correctly.

Disconnect by pulling Ring (17) while applying a counterclockwise motion.

7.3.2 Connect the test unit to fluid pressure source capable of 100 psi pressure by means of another unisex coupling. Cap the inlet of the test unit. Apply pressure of 5 and 100 psig to the system and observe for external leakage. There should be no leakage over a period of at least one minute. Reduce the system pressure.

7.3.3 Remove test unit from the test system and install the dust cap.

## 8.0 ILLUSTRATED PARTS CATALOG

Table 1.0 tabulates the parts and sub-assemblies comprising Model 64019 and Model 64319 Non-valved Unisex Couplings. The item numbers of the table are keyed to the exploded views of the unit diagrammed in Figure 1.

**TABLE 1.0**  
Ref. Figure 1

Fig.	Item	Part Number	Description	Units/ Assy	64019 Option	64319 Option	Spares/10 Units/Yr
1	1	GF35206-276	Screw	1	All	All	-
	2	MS29513-010	Packing	1	All	All	10
	3	220265	Ball	41	All	All	-
2	4	220141-1	Inlet, 2" Male NPT, Tan	1	J	22	-
		220141-2	Inlet, 2" Male NPT, Green	1	JV	V22	-
		220580-1	Inlet, 1" Male NPT, Tan	1	S	20	-
		220508-2	Inlet, 1" Male NPT, Green	1	SV	V20	-
		221504-1	Inlet, 1 7/8" 16 UN-2A Male, Tan	1	D	43	-
		221504-2	Inlet, 1 7/8" 16 UN-2A Male, Green	1	DV	V43	-
		221674-1	Inlet, 1 1/2" Male NPT, Tan	1	G	21	-
		221674-2	Inlet, 1 1/2" Male NPT, Green	1	GV	V21	-
		221242-1	Inlet, 2" Male BSPP, Tan	1	K	41	-
		221242-2	Inlet, 2" Male BSPP, Green	1	KV	V41	-
		221393-1	Inlet, 3" Male NPT, Tan	1	L	23	-
		221393-2	Inlet, 3" Male NPT, Green	1	LV	V23	-
		221515-1	Inlet, 3" Male BSPP, Tan	1	M	42	-
		221515-2	Inlet, 3" Male BSPP, Green	1	MV	V42	-
	5	220497-1	Inlet, 2" Female BSPP, Tan	1	P	51	-
		220497-2	Inlet, 2" Female BSPP, Green	1	PV	V51	-
		220138-1	Inlet, 1 1/2" Female NPT, Tan	1	R	31	-
		220138-2	Inlet, 1 1/2" Female NPT, Green	1	RV	V31	-
	6	220140-1	Inlet, 2" Male Camlock, Tan	1	F	61	-
		220140-2	Inlet, 2" Male Camlock, Green	1	FV	V61	-
	6A	GF27028-11-TN	Dust Cap, Tan	1	Q	Q	-
		GF27028-11-GN	Dust Cap, Green	1	QV	QV	-
	6B	221272	Inlet, 2" Hose Barb, Tan	1	E	81	-
	7	47037-1	Inlet Assembly, D-1/D-2 Flange, Tan	1	N	90	-
		47037-2	Inlet Assembly, D-1/D-2 Flange, Green	1	NV	V90	-
	8	220174-1	Inlet, D-1/D-2 Flange, Tan	1	N	90	-
		220174-2	Inlet, D-1/D-2 Flange, Green	1	NV	V90	-
	9	GF35308-334	Screw	6	N, NV	90, V90	-
	10	GF960C516	Washer	12	N, NV	90, V90	-
	11	GF21083C5	Nut	6	N, NV	90, V90	-
1	12	201201-151	O-ring	1	N, NV	90, V90	10
	13	47115-40	Screen Assembly – 40-mesh	1	A	A	-
		47115-60	Screen Assembly – 60-mesh	1	B	B	-
		47115-100	Screen Assembly – 100-mesh	1	C	C	-
		208092-40	Screen, 40-mesh (used on older units only on Option N)	1	AN, ANV	A90, AV90	-
		208092-60	Screen, 60-mesh (used on older units only on Option N)	1	BN, BNV	B90, BV90	-
		208092-100	Screen, 100-mesh (used on older units only on Option N)	1	CN, CNV	C90, CV90	-

Fig.	Item	Part Number	Description	Units/ Assy	64019 Option	64319 Option	Spares/10 Units/Yr	
1	14	MS29513-228	Packing	1	All	All	10	
	15	220330	Spring	1	All	All	-	
	16	220146	Seal	1	All	All	10	
	17	220482	Ring	1	All	All	2	
	18	220148	Pin	1	All	All	-	
	19	220301	Spring	1	All	All	-	
	20	220161	Bumper	1	All	All	5	
	21	GF16997-20L	Screw	4	All	All	-	
	22	220159-1	Lug, long	1	All but Z	All but Z	-	
		220805-1	Lug, long, stainless steel	1	Z	Z	-	
	23	220159-2	Lug, short	1	All but Z	All but Z	-	
		220805-2	Lug, short, stainless steel	1	Z	Z	-	
	24	47062	Dust Cap Assembly	1	All	All	2	
	25	220162	Cap	1	All		2	
	26	220146	Seal	1	All		10	
	27	28-2-G	Sleeve	2	All	All	4	
	28	82499-1800	Cable	1	All	All	1	
	29	220164-1	Body (tan)	1	All but V	All but V	-	
		220164-2	Body (green)	1	V	V	-	
	34	220335	Spring	1	All	All	-	
	35	220265	Ball	1	All	All	-	
	36	220334	Retainer	1	All	All	-	
	2	30	220170-1	Elbow (tan)	1	64023E	64023E	-
			220170-2	Elbow (green)	1	64023EV	64023EV	-
		31	220169-1	Tee (tan)	1	64022E	64022E	-
			220169-2	Tee (green)	1	64022EV	64022EV	-
		32	220172-1	Cross (tan)	1	64030E	64030E	-
			220172-2	Cross (green)	1	64030EV	64030EV	-
		33	220171-1	"Y" (tan)	1	64029E	64029E	-
			220171-2	"Y" (green)	1	64029EV	64029EV	-
34		220335	Spring	1	All	All	-	
35		220265	Ball	1	All	All	-	
36		220334	Retainer	1	All	All	-	
-		KD64019-1	Kit of seals for 64019 with single coupling, except N option (use -5) - contains items 14, 16 & 26.					
-		KD64019-2	Kit of seals for 64023E Elbow - contains items 14, 16 & 26 in appropriate quantities.					
-		KD64019-3	Kit of seals for 64022E Tee & 64029E "Y" - contains items 14, 16 & 26 in appropriate quantities.					
-		KD64019-4	Kit of seals for 64030E Cross - contains items 14, 16 & 26 in appropriate quantities.					
-		KD64019-5	Kit of seals for 64019N - contains items 12, 14, 16 & 26.					



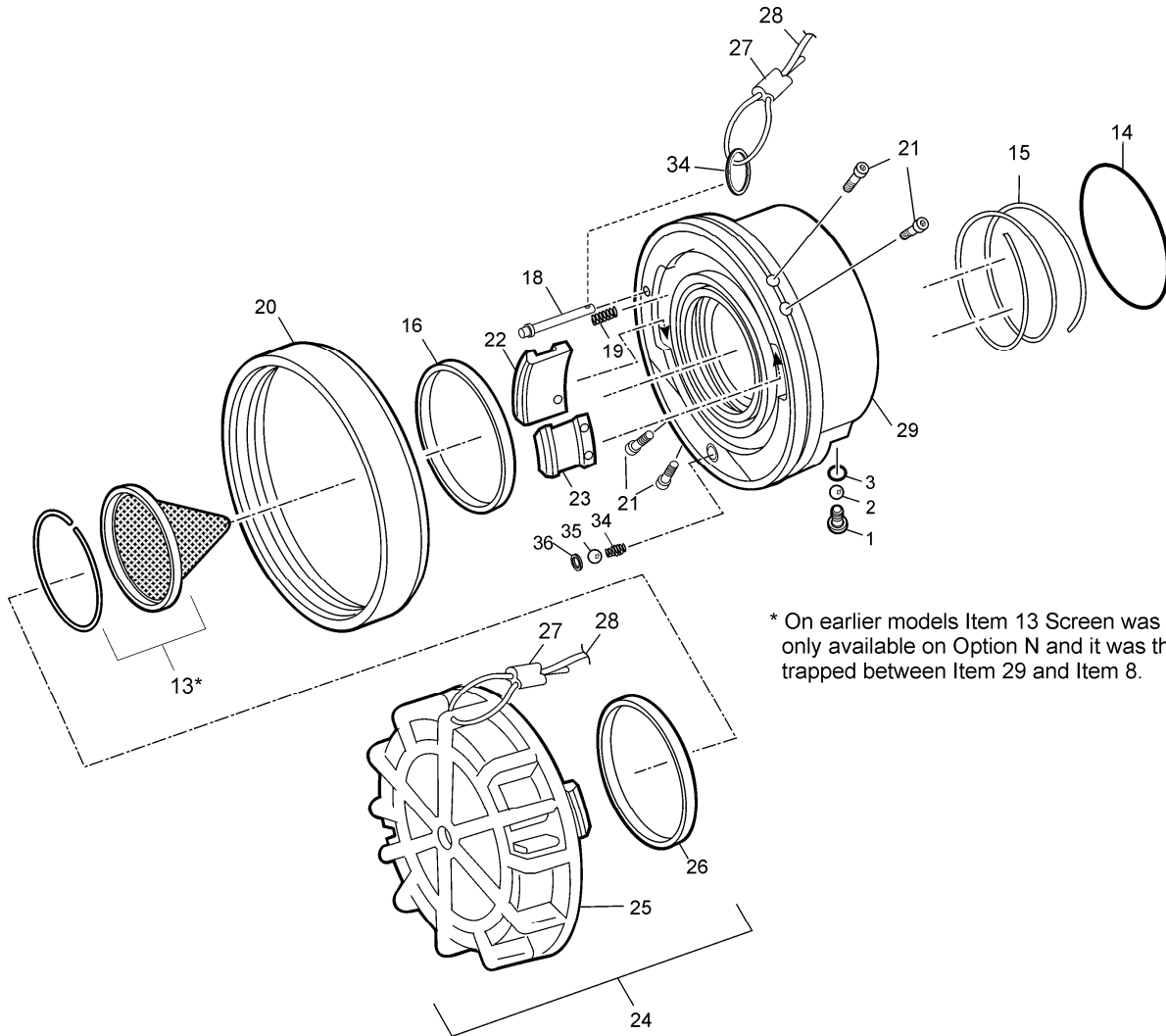

\* On earlier models Item 13 Screen was only available on Option N and it was then trapped between Item 29 and Item 8.

**FIGURE 1 – BASIC UNIT BREAKDOWN**

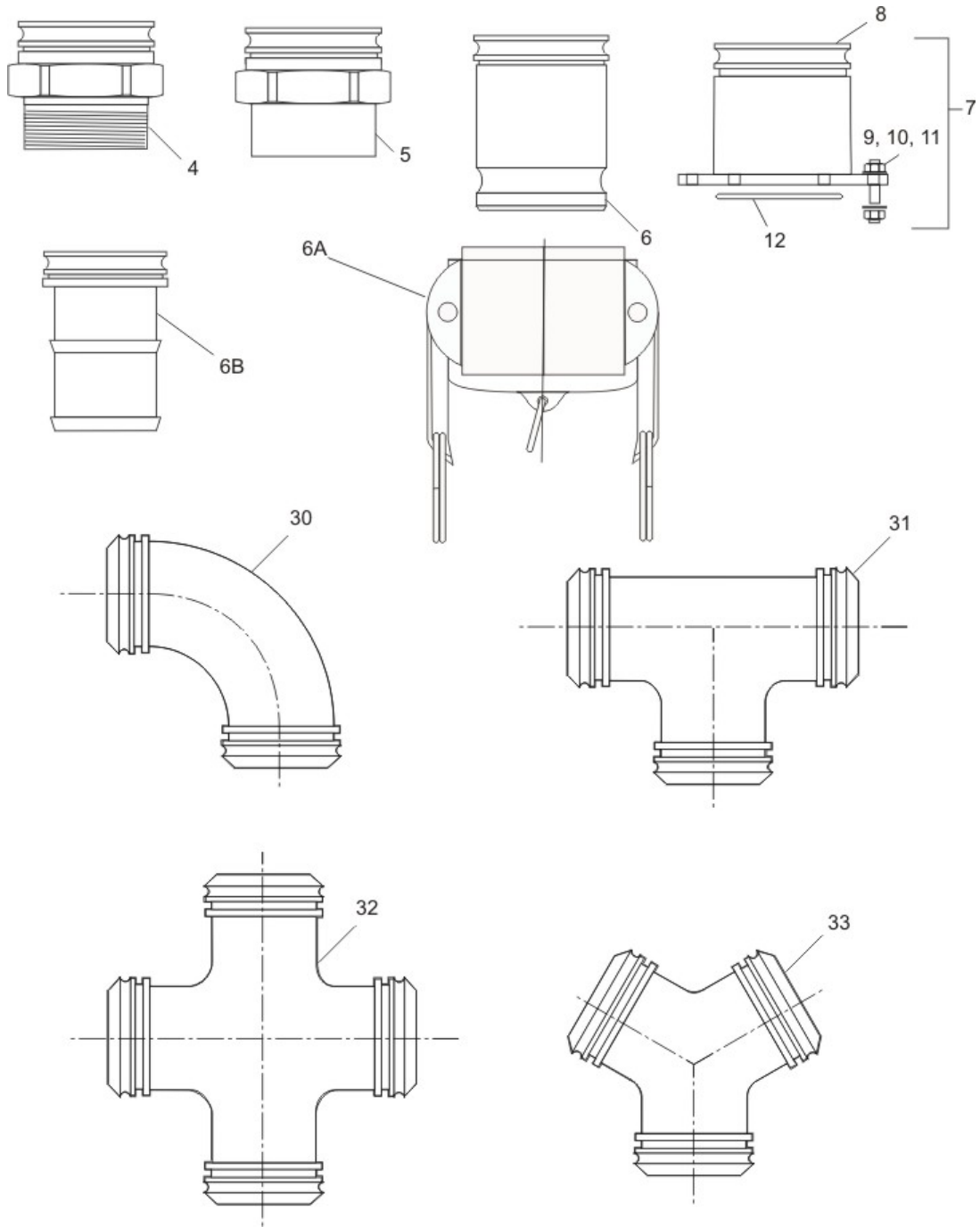

**FIGURE 2 – INLET OPTIONS AVAILABLE**



Aerospace Group  
Conveyance Systems Division  
9650 Jeronimo Road  
Irvine, CA USA 92618  
Ph: (949) 452-9500  
Fax: (949) 452-9992



*Powering Business Worldwide*