



*Powering Business Worldwide*

Aerospace Group  
Conveyance Systems Division  
Carter® Brand

## **SM64155**

September 2011

Applicable addition manuals:

SM61429 Nozzle

SM64349 Nozzle

SM64201 Nozzle

### **Maintenance & Repair Manual**

---

**Continuity Dry Break Swivel Quick Disconnect  
To Mate D-1 or D-2 Nozzles - Models 64349H or 64349J  
(Also used on older Model 61429 Nozzles)**

---

### **Model 64155**

## TABLE OF CONTENTS

1.0 INTRODUCTION .....	3
2.0 EQUIPMENT DESCRIPTION .....	3
3.0 SPECIAL TOOLS .....	3
4.0 DISASSEMBLY .....	3
5.0 INSPECTION.....	5
6.0 REASSEMBLY .....	6
7.0 TEST .....	7
8.0 ILLUSTRATED PARTS CATALOG.....	8
Figure 1 - Major Sub-assembly Breakdown .....	10
Figure 2 - Female Quick Disconnect Half Parts Breakdown .....	11
Figure 2 Continued - Switch Assembly .....	12
Figure 3 - Male Half Quick Disconnect Parts Breakdown .....	12
Figure 4 - Spring Installation Tool .....	13
Figure 4 Spring Installation Tool.....	13
Figure 5 Check Valve Installation Tool.....	14
Figure 6 Wear Ring Installation Tool.....	14
Figure 7 Wear Ring Removal Tool.....	15

## Maintenance, Overhaul & Test Instructions

### Eaton's Carter Brand Model 64155

#### Continuity Swivel Quick Disconnect

#### 1.0 INTRODUCTION

This manual furnishes detailed instructions covering the maintenance and overhaul of Eaton's Carter brand Model 64155 Continuity Dry Break Swivel Quick Disconnect Assembly.

The 64155 Continuity Dry Break Swivel Disconnect when procured as a complete unit includes:

- Female Half - Continuity Dry Break Swivel Disconnect with 2 ½" NPT Threaded Inlet to attach to the hose.

- 60-mesh Strainer Assembly with retaining clip.
- Male Half Adapter to mate D-1 or D-2 Nozzle inlet flange with mating o-ring seal and seals to mate with Female Half above.

There are currently no options offered to this equipment.

#### 2.0 EQUIPMENT DESCRIPTION

Model 64155 Continuity Dry Break Swivel Disconnect is designed to be used on any military standard D-1 or D-2 nozzle including Carter brand Model 64349H or 64349J nozzles. It provides connection to the refueling hose fitting and a quick dry means of disconnecting the nozzle from the hose for inspection of the screen utilized therein. A check valve that closes upon disconnect of the two halves is included in the unit to provide a relatively

dry disconnect. Note – fuel in the nozzle end of the unit is not restrained and the disconnect should be made over a container to collect this fuel. Disconnection is easily achieved without the use of any tools.

An on-off switch is included in the mechanism to interrupt electrical continuity between the unit and the hose. The switch is used to start/stop the fuel delivery pump located remote to the nozzle.

#### 3.0 SPECIAL TOOLS

The following special tools or their equivalents should be utilized to accomplish the overhaul and repair of the subject units:

- 6912-ST1 -- Utilized to properly wind the two coil springs and install them in the check valve assembly. Not required if check valve is procured as a complete spare part, which is highly recommended.
- 43113-ST1 -- For use in assembling the check valve assembly into the housing.

- 44752 -- For use in installing the ball race Wear Rings (3-3) onto the various male adapters to prevent damage to the Adapters.
- 210367 -- For use in removing worn ball race Wear Rings (3-3) from the various male adapters to prevent damage to the Adapters.
- IF220351 -- Go-no go gauge for checking wear on Sleeve (2-6).

#### 4.0 DISASSEMBLY

4.1 Remove nozzle/swivel quick disconnect from end of hose. Depress the Interlock Levers (2-7) and move the Sleeve (2-6) toward the inlet of the unit. Grasp the Male Adapter Half Assembly (1-5) and

twist while applying pressure to separate the two halves of the Disconnect.

4.2 Pre-disassembly Inspection of Sleeve (2-6) - Prior to disassembling Female Half Disconnect (1-1), perform the following inspection procedure:

Slide the Sleeve (2-6) to the locked position (away from the threaded end of the Housing (2-1) and allow it to lock in place.

- Attempt to insert gauge IF220351 into the open end (opposite to the threaded end). If the gauge slides into the part, the Sleeve (2-6) is worn out and has to be replaced. If the gauge does not enter the part, the unit is acceptable for use and disassembly can continue as below.

- 4.3 The Screen (1-3) may be removed for replacement or cleaning by removing its Retainer (1-4) first.

**Note:**

The tangs of the Retainer (1-4) should always be installed facing the screen to prevent them from interfering with the Actuator (2-2) of the Check Valve Assy (2-19). If installed otherwise it will hamper proper swiveling action.

- 4.4 While holding the Sleeve (2-6) in the retracted position remove Retaining Ring (2-32). Use a small blade screwdriver or a sharp pointed instrument to lift one end of the Retaining Ring (2-32) free from its groove and peel the ring off of the Housing (2-1). Remove the Sleeve Assembly (2-5), Spring (2-30), and Balls (2-31).

- 4.5 If the Interlock Levers (2-7) and Springs (2-9) are not damaged do not disassemble the Sleeve Assembly (2-5) further. If necessary to replace either the Interlock Levers (2-7) or the Springs (2-9), use a .093 (2.362 mm) drift pin to drive the Roll Pin (2-8) out of the sleeve assembly.

**Note:**

Make sure that the part is properly supported prior to using drift pin otherwise damage to the sleeve may occur.

- 4.6 **Wear Ring (2-29), located inside the Housing (2-1) should not be disassembled until the inside diameter has been inspected in accordance with paragraph 5.5 below.** If replacement is necessary, it can be removed by use of a

small blade screwdriver to pry one end out of the groove. Then carefully remove the entire band.

- 4.7 If the Check Valve (2-21) is to be overhauled or the o-ring sealing the check valve needs replacing, first with a small blade screwdriver or sharp pointed instrument remove Ring (2-29) from its internal groove and peel it out. Grasp the Actuator (2-2) and simultaneously turn and pull it out of the Housing (2-1). Remove O-ring (2-27) from the internal groove and discard it. Remove Screw (2-4), Actuator (2-2), Spring (2-3) from Check Valve Assy (2-19).

- 4.8 **Unless the special tools that are recommended in paragraph 3.0 are available it is recommended that the Check Valve Assy (2-19) be replaced as a complete part number and that it not be disassembled further.** If disassembly is to be achieved, apply light finger pressure slightly off center and downward on top of Springs (2-23) & (2-24). Using a 1/8" (3.18 mm) diameter pin push on Hinge Pin (2-22) until it protrudes approximately 3/4" (19 mm) out of opposite side. While maintaining finger pressure on Springs (2-23) & (2-24), remove Hinge Pin (2-22) by pulling on the protruding pin. Slowly release pressure from springs being careful not to allow springs to unwind rapidly. After Springs (2-23) & (2-24) have been removed, Check Valves (2-21) may be removed from Retainer Assy (2-20). Care should be taken not to lose Spacers (2-25) when removing Check Valves (2-21). **Note orientation of Spacers (2-25) and Washers (2-26) for proper reassembly.**

- 4.9 Remove and discard O-ring (3-8) from Male Half Adapter Assembly (1-5). **Do not remove Wear Ring (3-2) from Adapter Assembly (1-5) until the outside diameter has been inspected in accordance with paragraph 5.4.** If necessary to replace, carefully, using a small blade screwdriver, pry the Wear Ring (3-2) from its groove and peel it from the part and discard.

- 4.10 **The Ball Race Rings (3-3) need not be disassembled from the Adapter Assembly (1-5) unless evidence of wear or brinelling is apparent.** Removal requires the use of tool number 210367 to prevent damage to the Adapter (3-1).

The tool is slipped onto the Adapter (3-1) and one end of the Race Ring (3-3) is carefully pried up onto the tool surface. The Race Ring (3-3) is then carefully unwound from the Adapter (3-1) onto the tool. The tool is then removed from the Adapter (3-1). Refer to Figure 7 for further information.

- 4.11 Remove Screws (2-16) that hold Guard (2-17) in place. Remove Guard (2-17) and discard if worn sufficiently to expose the switch to damage due to handling.

**NOTE:**

The Guard (2-17) must be removed to gain access to the Switch Assembly (2-18) to prevent damage to the switch.

- 4.12 Proceed further only if the Switch Assembly (2-18) needs replacement or there is a leak of fuel from the unit in the vicinity of the switch. Using a small blade screwdriver or other sharp instrument remove Retainer Ring (2-30). Grasp Switch Assembly (2-18) and slowly pull it from the Housing (2-1) until the terminals to the attached wires are exposed.

**CAUTION!**

**Do not jerk Switch Assembly (2-18) from Housing (2-1). This may damage the leads from the switch to the housing.**

If the Switch Assembly (2-18) is being replaced the lead wires to the unit may be cut to get it out of the way. Using a right angle Allen Key to remove terminal Screw (2-34). Do not remove Pin (2-11) unless it has been damaged. Remove and discard O-Ring (2-38).

- 4.13 Remove remaining Screws (2-16). Reach into the inlet of the Housing (2-1) and push the Plug (2-14) out. The Switch Assembly (2-18) and Plug (2-14) will still be connected with one wire. Remove and discard O-ring (2-12) from Plug (2-14). Remove Screw (2-35). Remove Spring (2-15) and discard. Discard Switch Assembly (2-18), it is not designed to be overhauled in the field. Do not remove Pin (2-11) unless it has been damaged.
- 4.14 Remove Conductor (2-10) and O-ring (2-13). Discard O-ring (2-13).

## 5.0 INSPECTION

It is recommended that O-Rings (3-4) and (3-8) be replaced upon each overhaul of the Unit. If the Switch Assembly (2-18) is to be replaced O-rings (2-10), (2-11) and (2-38) need to be replaced also. In addition Switch Assembly (2-18) will need replacing as a complete unit.

- 5.1 Inspect all metal parts for dings, gouges, abrasions, etc. Use 320 grit paper to smooth and remove sharp edges. Replace any part with damage exceeding 15% of local wall thickness. Use Alodine 1200 to touch up bared aluminum.
- 5.2 Inspect inside of Sleeve (2-6) for indications of brinelling or ball indentations at intersection of tapered surface with constant inside diameter at ball lock area as well as for cracks, excessive abrasions, or other damage. Replace Sleeve (2-6) if damaged or worn as described above. Depress the Thumb Interlock Levers (2-7) to assure that they

will return smartly from a fully depressed position. If not, replace the Spring (2-9).

- 5.3 Inspect Housing (2-1) for cracks around the end opposite the threaded inlet at the Retainer Ring (2-32) groove. Check the inside diameter of the Housing (2-1) adjacent to the Wear Ring (2-32) for evidence of extreme galling. Measure this diameter, it shall be a minimum of 3.009 (74.302 mm). If less than this diameter replace it. Excessive galling on this diameter means that the Wear Rings (3-2) and (2-29) should be replaced. Replace if evidence of cracking is present or excessive wear is apparent.
- 5.3 Check the leading diameter on the opposite end to the flange of the Male Half Adapter Assembly (1-5) for evidence of extreme galling. If this diameter is less than 2.989 (74.921 mm) at any point it should be replaced. Evidence of extreme galling, even though the diameter is greater than this dimension, means that

- the Wear Rings (3-2) and (2-29) need replacing.
- 5.4 Measure the outer diameter of the Wear Ring (3-2) on the Male Adapter Assembly (1-5). The minimum diameter shall be 3.037 inches (76.140 mm). If less than this dimension, replace it.
- 5.5 Measure the inside diameter of the Wear Ring (2-29) located within the Housing (2-1). The maximum diameter of this part shall not exceed 3.007 inches (74.378 mm). If more than this dimension, replace it. Inspect the rubber-bonded seats of the Retainer Assy (2-20) for nicks, voids, cracks or build-up of foreign material on the rubber seats. Inspect the Check Valves (2-21) for nicks or scratches on the sealing surfaces. Check Hinge Pin (2-22) hole areas for cracks or excessive wear.]
- 5.6 Inspect Guard (2-17) for excessive wear that will allow the toggle switch to be exposed to wear or damage during handling. Replace as needed.
- 5.7 Inspect Heli-Coil inserts in Housing (2-1) by installing Screw (2-16) and ensuring there is a significant amount of force required to retain Screw (2-16)

## 6.0 REASSEMBLY

- 6.1 Reassemble in reverse order of disassembly, observing the following:
- 6.2 Make certain all components are clean and free from oil, grease, or any other corrosion resistant compound on all interior or exterior surfaces. Wash all parts with cleaning solvent and dry thoroughly with a clean, lint-free cloth or compressed air.
- WARNING:**  
**Use cleaning solvent in a well-ventilated area. Avoid breathing of fumes and excessive solvent contact with skin. Keep away from open flame.**
- NOTE: A light coat of petrolatum can be applied to all o-rings and screws for ease of installation
- 6.3 Set Retainer Assy (2-20) on a flat surface with the rubber seat side up. Lay both Check Valves (2-21) in the position shown in the exploded view. Apply a light coating of petroleum jelly to Spacers (2-25) and Washers (2-26) and carefully install in positions indicated with a pair of tweezers. Using Installation Tool 6912-ST1 (Figure 4, View A) place Springs (2-21) and (2-22) into Tool Base Saddle with straight portion of end coil into slot in Base and under the pin at point "A" as shown in Figure 4. Insert Mandrel Shaft into inside diameter of one spring and rotate Mandrel until screw in Mandrel picks up end coil at point "B" in Figure 1. Continue rotating Mandrel in direction to tighten spring coil winding spring approximately 360° (one full turn). Transfer end coil from screw on mandrel onto the screw head on the Base at point

"C" in Figure 1. Repeat the coil winding operation with the second spring. With both springs installed and wound per above place the Installation Tool (Saddle Base less Mandrel) (see Figure 4, View B), with springs facing the Check Valves (2-21), Insert Hinge Pin (2-22) through holes on one side of Retainer Assy (2-20). Align Spacers (2-25) and Washers (2-26) with holes in the hinge portion of the Check Valves (2-21). Push the Hinge Pin (2-22) through the aligned holes of details described above and the center of the coils of the Springs (2-21) and (2-22). With a thin blade screw driver or a pointed instrument, lift the tangs of the springs closest to the outer edge of the Retainer Assy (2-20) off the edge of the small screw holding the tangs in place on the Installation Tool. After the tangs have been lifted off the screws on the tool, slide the installation tool off the tangs of the springs located at the centerline of the Check Valve Assy (2-19).

- 6.4 Following assembly, the Check Valves (2-21) should be actuated manually to assure free movement with no evidence of binding. The Check Valves (2-21) should contact the seat evenly on all surfaces.
- 6.5 Install new O-ring (2-27) into Housing (2-1) and lubricate with petroleum jelly. Install Check Valve Assy (2-19) into Housing until it is fully seated, such that the Check Valves (2-21) open toward the threaded end of the unit. Lubricate the inside diameter of the hollow Sleeve from Installation Tool 43113-ST1 with petroleum jelly (refer to Figure 5). Insert this sleeve fully into bore of the Housing.

- Insert Retainer Ring (2-29) into the open end of the Sleeve. Place the entire assembly into an arbor press and insert the small end of the mandrel part (solid round part) of the Installation Tool into the Sleeve. Press mandrel downward until Retainer Ring (2-29) snaps into its groove. Remove Installation Tool. Check Valve Assy (2-19) should be completely retained into Housing (2-1).
- 6.6 Lubricate threads on Screw (2-4) with petroleum jelly. Slide Actuator (2-2) over Screw (2-4). Slide Spring (2-3) over Screw (2-4). Then tighten Screw (2-4) into thread of Check Valve Assy (2-19) until it bottoms.
- 6.7 If the Interlock Lever (2-7) and Spring (2-9) were removed during disassembly, position the Interlock Lever (2-7) into the approximate location required. **One of the holes, for the Pin (2-8), is larger than the other to allow easier installation.** Push the Pin (2-8) into the larger hole and into one leg of the Interlock Lever (2-7). Push the Spring (2-9) under the Interlock Lever (2-7), with the open ends of the Spring (2-9) against the Housing (2-1), until the Pin (2-8) can be inserted into the coil diameter and on into the other hole of the Interlock Lever (2-7). Locate the other hole in the Sleeve (2-6) and drive the Pin into it for approximately 0.25 (4.35 mm). Check to see that the Interlock Lever (2-7) is spring loaded and will return from the fully depressed position. When installing the Sleeve (2-6), Spring (2-30) and Balls (2-31) it is recommended that the Balls be coated with petroleum jelly to retain them in the holes in the Housing (2-1).
- 6.8 Assemble Balls (2-31) into Housing (2-1). Petroleum jelly may be used to hold balls in place while proceeding with assembly. Assemble Spring (2-30) onto Housing (2-1) and slide Sleeve (2-6) over Spring (2-30) and push Sleeve (2-6) down until the Retainer (2-23) can be installed into its groove in the Housing (2-1). After completing assembly it is recommended that the assembly be cleaned with solvent to remove the petroleum jelly used during assembly.
- 6.9 If the Ball Race Wear Rings (3-3) were removed and are to be replaced, use tool 44752 for the installation of new ones. See Figure 6 for further information.
- 6.10 Install O-ring (2-12) onto Plug (2-14) before installing plug with Screws (2-16) such that the hole in the outer diameter mates the pin in Housing (2-1). This locates the Conductor (2-10) in the correct orientation. Install O-ring (2-13) onto Conductor (2-10). Install the Conductor (2-10) into the Plug (2-14).
- 6.11 Install O-Ring (2-38) the groove in the Main Housing (2-1). The forked end of Spring (2-15) slips into the groove in the head of Conductor (2-10) and is retained by Screw (2-35) to which one lead (either from the Switch Assembly (2-18) is attached. (Point "A" in Figure 2). Loosen the Conductor (2-10) as necessary to allow the Spring (2-15) to be inserted into the groove in the head of Conductor (2-10). After the Spring (2-15) and the lead from the Switch Assembly (2-18) are installed tighten the Conductor (2-10) and the Screw (2-35). Do not over tighten – the plug is plastic. Switch Assembly (2-18) is coated at the factory with 3M Scotch-Weld Potting Compound (2-36).
- 6.12 The other lead is attached to the Housing (2-1) by Screw (2-34). (Point "B" in Figure 2). Apply a light coat of petrolatum to outer diameter of Switch Assembly (2-18). The Switch Assembly (2-18) is located in place to prevent rotation by hole provided to mate with Pin (2-11). Secure the Switch Assembly (2-18) in the Housing (2-1) with the Retaining Ring (2-33). Note that the Switch Assembly (2-18) when installed correctly will position the "OFF" marking adjacent to the inlet of the Housing (2-1).
- 6.13 Secure Guard (2-17) using Screws (2-16) and ensure Screws (2-16) are help securely in place..
- CAUTION!**  
It is extremely important to follow the instructions to prevent the screws or the guard from becoming FOD.

---

## 7.0 TEST

The unit shall be tested as a part of a completed nozzle, as instructed in the

appropriate nozzle service manual, with the addition of the tests shown below.

- 7.1 Test conditions  
Test media shall be odorless kerosene or JP-5 Jet Fuel or equivalent.
  - 7.2 Functional Test  
As mentioned above the Unit should be tested with its mating nozzle. Disengage Housing Assembly from nozzle/adapter. Apply 60-psi pressure to the hose inlet and observe leakage from the outlet.
- There shall be no leakage from the outlet during a one-minute observation period.
- If available use a continuity-checking device to test the switch continuity. Touch one pointer of the device to the Conductor (2-10) and the other to the unanodized section of the inlet thread. If the switch is in the "on" position continuity should be noted. When the switch is in the "off" position no continuity should be noted.

8.0 ILLUSTRATED PARTS CATALOG

The 64155 Dry Break consists of two major sub-assemblies plus a screen assembly as shown in Figure 1. Either of the major sub-assemblies can be

procured as a separate part as noted below. Refer to the appropriate figures for parts identification.

**TABLE 1  
COMPLETE PARTS BREAKDOWN LISTING**

Fig.	Item	Part Number	Description	Units/ Assy	Spares/10 units /yr
1	1	47358	Female Half – Continuity Dry Break Disconnect .....	1	-
2	1	221230	Housing .....	1	-
	2	201900	Actuator .....	1	-
	3	203393	Spring, Actuator .....	1	-
	4	207604	Screw .....	1	-
	5	44659	Sleeve Assembly.....	1	-
	6	209884	Sleeve.....	1	-
	7	209885	Lever.....	2	-
	8	210151-3	Pin.....	2	-
	9	209946	Spring .....	2	-
	10	209875	Conductor .....	1	-
	11	210151-2	Pin .....	2	-
	12	201201-114	O-ring .....	1	10
	13	201201-008	O-ring.....	1	10
	14	209877	Plug .....	1	-
	15	221232	Spring.....	1	-
	16	GF24693C48	Screw .....	6	-
	17	221205	Guard.....	1	-
	18	47331	Switch Assembly .....	1	-
	19	47337	Check Valve Assembly .....	1	-
2	20	47336	Retainer Assembly .....	1	-
	21	201901	Check Valve .....	2	-
	22	203390	Pin, Hinge.....	1	-
	23	23739-5	Spring.....	1	-
	24	23739-6	Spring.....	1	-
	25	23741	Spacer .....	2	-



Fig.	Item	Part Number	Description	Units/ Assy	Spares/10 units /yr	
	26	5710-21-10	Washer.....	4	-	
	27	201201-233	O-ring.....	1	10	
	28	RRT-287-S	Ring, Retaining .....	1	-	
	29	209976-2	Wear Ring, Female.....	1	-	
	30	221848	Spring, Sleeve Return.....	1	-	
	31	GF19060-4818	Ball .....	16	-	
	32	RS-354-S	Ring .....	1	-	
	33	WH-200-S02	Ring .....	1	-	
	34	GF1352C08-6	Screw.....	1	-	
	35	GF35272-226	Screw.....	1	-	
	36	DP-270	3M Scotch-Weld Potting Compound .....	Tube	1	
	37	Intentionally left blank				
	38	M25988/1-135	O-Ring	1	10	
1	2	44373-60	60-mesh Screen Assembly .....	1	-	
	3	208092-60	Screen.....	1	-	
	4	208091	Ring, Retaining.....	1	-	
	5	44663	Male Half Adapter .....	1	-	
3	1	209856	Adapter.....	1	-	
	2	209971-1	Wear Ring, Male .....	1	-	
	3	207364	Ring, Ball Race .....	2	-	
	4	201201-151	O-ring .....	1	10	
	5	GF35308-334	Screw .....	6	-	
	6	GF960C516	Washer.....	12	-	
	7	GF21083-C5	Nut.....	6	-	
	8	221266	O-ring.....	1	10	

Spare parts kits are provided to handle most needs. Individual parts may also be procured however it is usually more economical to procure the parts in a kit. The contents of a kit can upon request be altered to suit actual needs. Kits available at the time of release of this document are presented below.

KIT PART NUMBER	DESCRIPTION	CONTENTS – REFERS TO APPROPRIATE DRAWING
KD64155-1	Switch Guard (2-17) replacement kit.	Items 2-16 (4 only)& 2-17
KD64155-2	Overhaul Kit for replacement of Switch Assembly (2-18). (Note 3)	Items 2-12, 2-13, 2-15, 2-16 (2 only), 2-18, 2-33, & 2-38
KD64155-3	Overhaul Kit for replacement of Check Valve Assembly (2-19). (Note 3).	2-2, 2-3, 2-4, 2-19, 2-28, & 2-33.
KD64155-4	Overhaul Kit needed to replace Wear Rings (2-9) & (3-2) with normal overhaul. (Note 3).	2-29, 3-2, 3-4 & 3-8.
KD64155-5	Fastener Kit containing fasteners used to connect 64155 to D-1 or D-2 Nozzles. (Note 3)	3-5, 3-6, & 3-7.

Notes:

1. All part numbers beginning with "GF" are interchangeable with those beginning with either "AN" or "MS". If the "GF" is followed by three numbers it is interchangeable with an "AN" part, otherwise it is interchangeable with an "MS" part of the same number.

2. The recommended spare parts shown above are the number required to support 10 Units for one year. The recommended quantities are based on the ratio of spare parts sold for each unit during a one-year period of time. The actual quantity required will vary from location to location.
3. Combination kits may be ordered if it is desired to overhaul more of the unit than any one kit is designed to handle. Example if a complete overhaul of the unit, including replacement of the Switch Assembly (2-18), Check Valve (2-21) and the Wear Rings (2-29) & (3-2) then the kit dash numbers may be combined to KD64155-2-3-4.

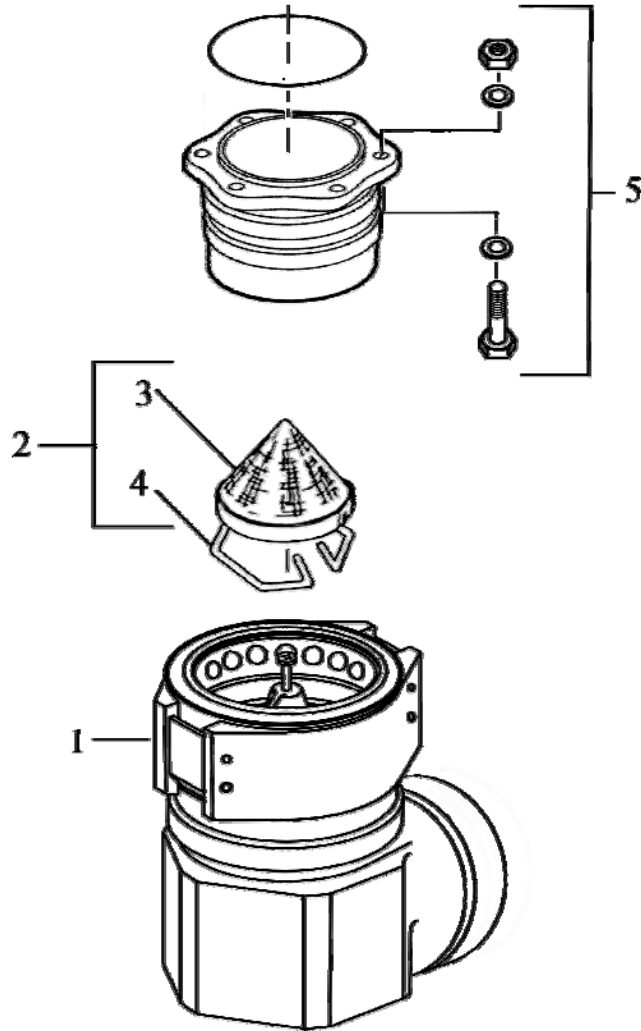

**Figure 1**  
**Major Sub-assembly Breakdown**

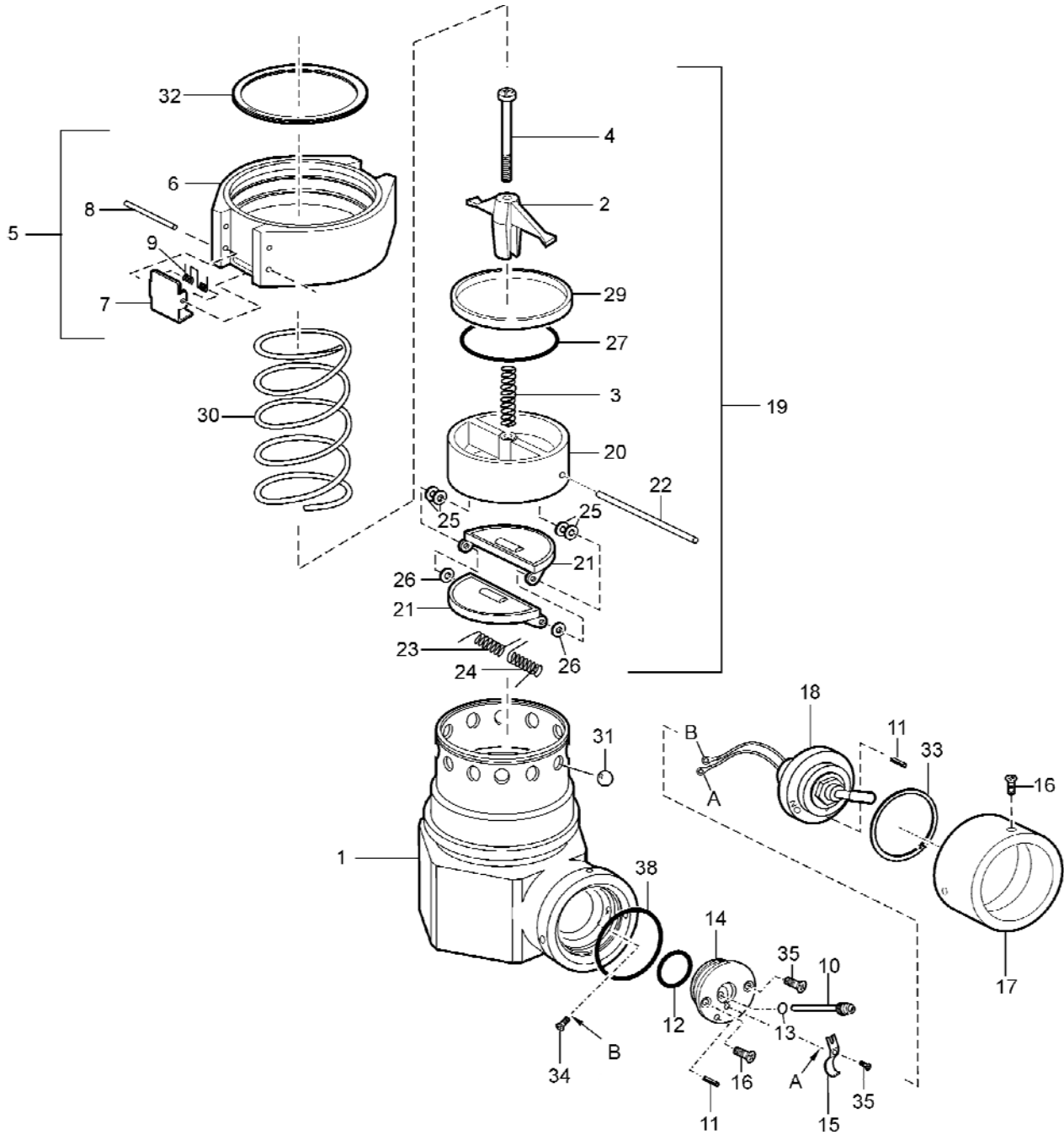

Notes:

1. Switch Assembly (18) leads A & B connect under Screws (35) and (34) respectively..

**Figure 2**  
**Female Quick Disconnect Half Parts Breakdown**

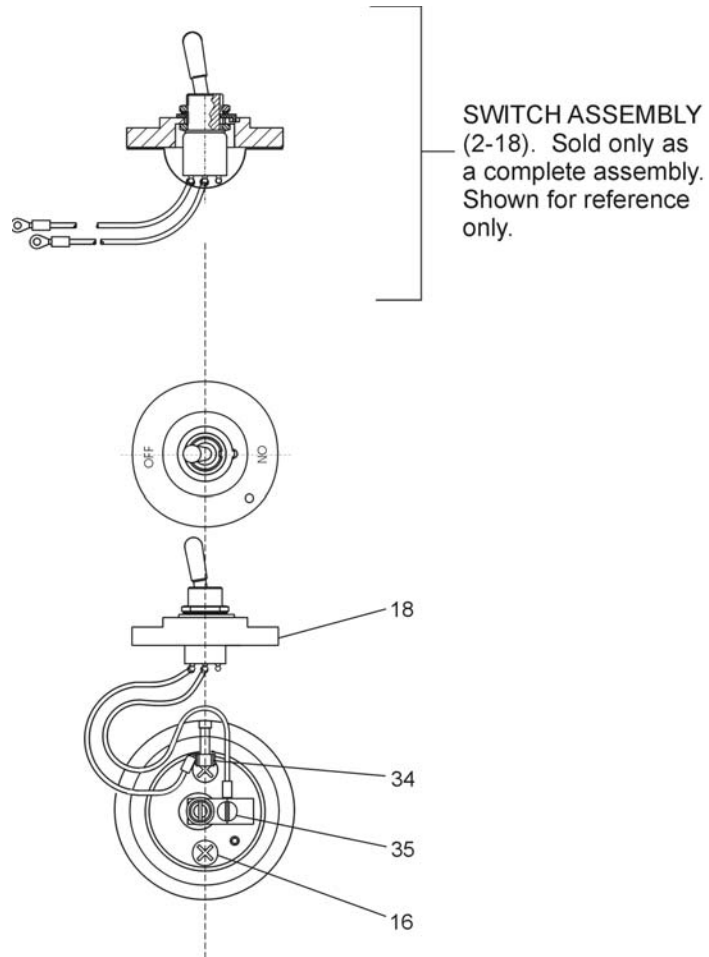

**Figure 2 Continued - Switch Assembly**

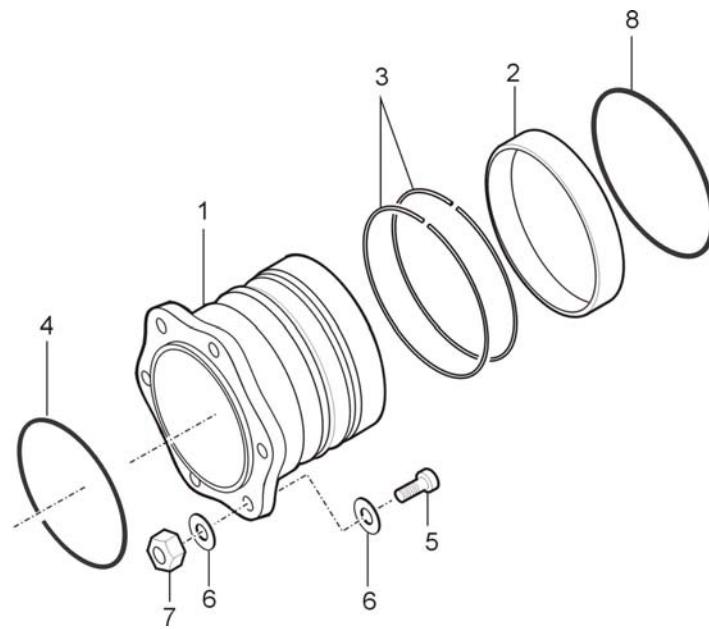

**Figure 3 - Male Half Quick Disconnect Parts Breakdown**

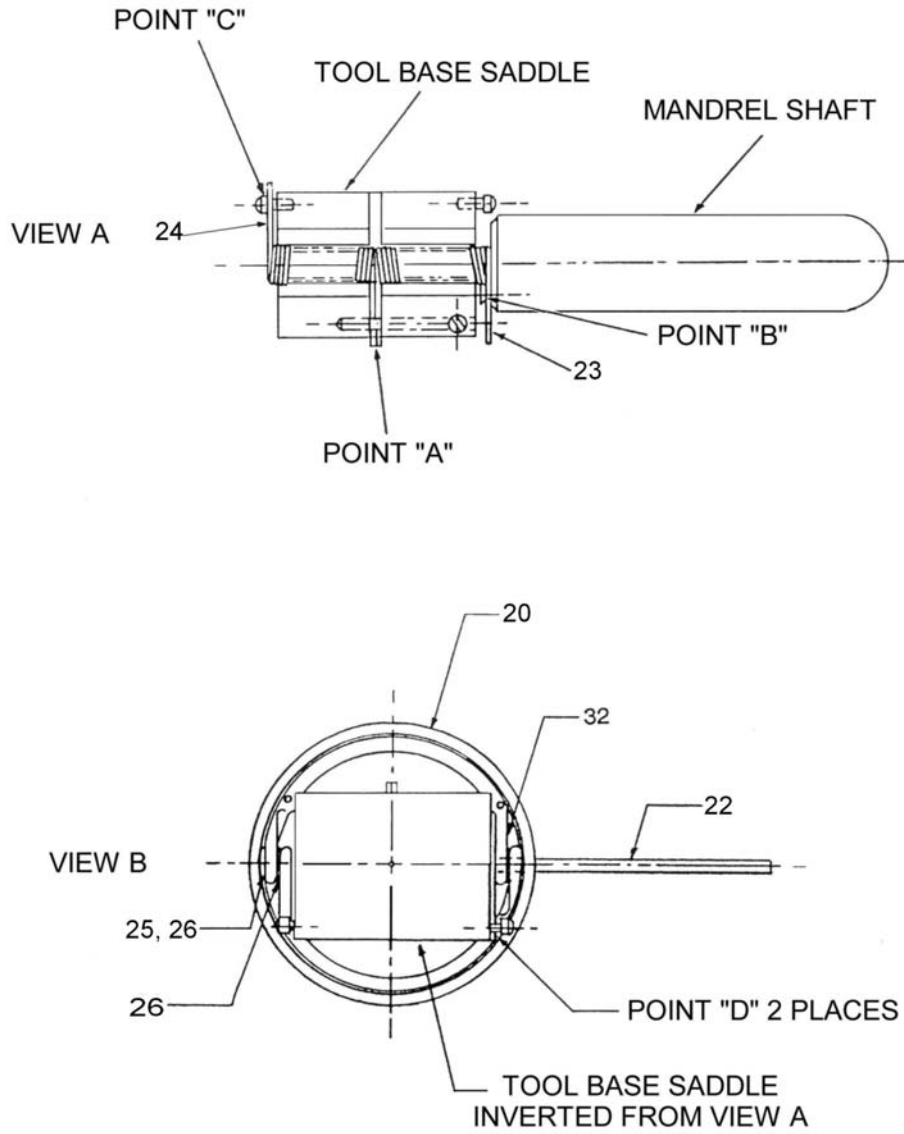
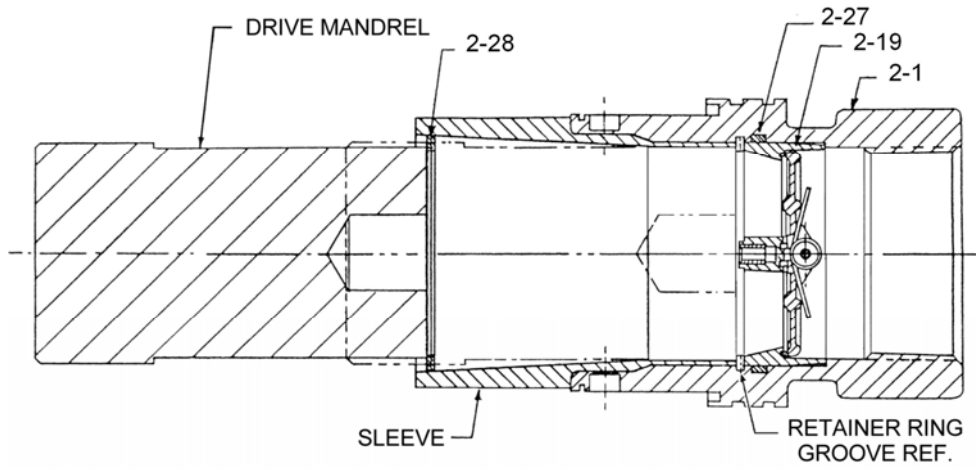
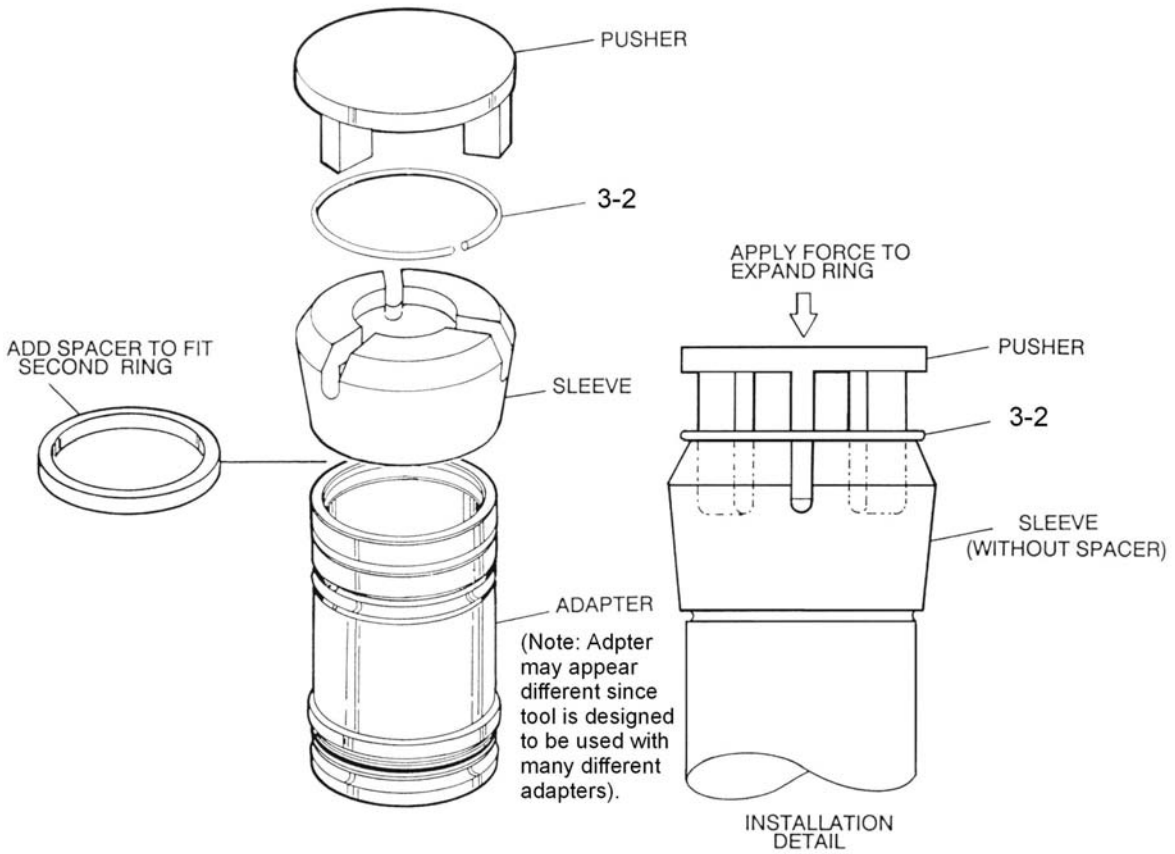

Figure 4 - Spring Installation Tool



**FIGURE 5 - Check Valve Installation Tool**



**Figure 6 - Wear Ring Installation Tool**

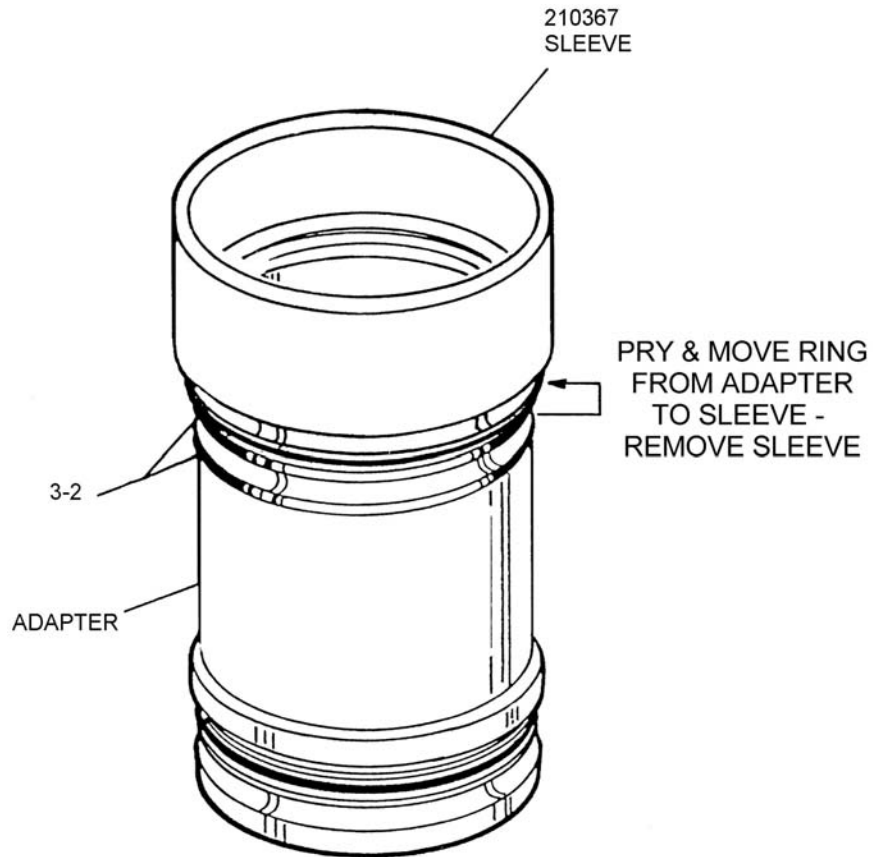

**Figure 7 - Wear Ring Removal Tool**

Eaton  
Aerospace Group  
Conveyance Systems Division  
Carter® Brand  
9650 Jeronimo Road  
Irvine, CA 92618  
Ph (949) 452-9500  
Fax (949) 452-9992



*Powering Business Worldwide*