



*Powering Business Worldwide*

Aerospace Group  
Conveyance Systems Division  
Carter® Brand Ground Fueling Equipment

**SM64349H**

July 1999

Applicable addition manuals:  
SM429MISC

## Maintenance Manual

---

**Pressure Fueling Nozzle** TYPE D-1 NSN 4930-01-385-8946

---

**Model 64349H**

SUMMARY OF REVISIONS

<u>DATE OF CHANGE</u>	<u>E.O. NO.</u>	<u>REV.</u>	<u>PARA. OR PAGE NO.</u>	<u>DESCRIPTION</u>	<u>APPROVED</u>
7/1/99		<b>B</b>	2.2.1.2	Added paragraph (last) regarding service bulletin.	
			3.2, 3.4	“several times” was “up to 15 times”	
			3.9	Added info about the shroud on the poppet	
			3.12	Revised to agree with the need to remove the Plug (22).	
			3.15	Added info about newer operating levers versus older ones.	
			3.15.1	Clarified disassembly method.	
			3.15.2	Added serial number info and clarified disassembly method..	
			3.16 & 3.17	Incorporated into 3.15.1 and .2.	
			4.0	Added last paragraph.	
			6.1.1	Removed “Federal Specification P-D-680”.	
			6.1.2.2	Torque at 125 was 60.	
			7.2.1	Removed reference to P-D-680 and Mil-F-5624.	
			Table 1	Revised to cover new production configuration only.	
				Item 16 was 46.	
				Added item 35A.	
				Item 3 – GF960-416 was GF960-516.	
				Items 7 & 23 – 220484 was 209827	
	Item 10 & 11 – 221075 was 82123.				
Table 1	Added “(Note 5)” with note at the end of the notes on page 16.				
Table 2	Added to cover older configurations only.				

<b>DATE OF CHANGE</b>	<b>E.O. NO.</b>	<b>REV.</b>	<b>PARA. OR PAGE NO.</b>	<b>DESCRIPTION</b>	<b>APPROVED</b>
6/1/98		<b>A</b>	2.2.1.1	"Collar (8) are" was "Collar (8) is" - typo	
			2.2.2.1	Added Strong Warning.	
			2.2.2.2	Added Thermal Expansion information.	
			2.2.2.3	2.2.2.3 was 2.2.2.1 – same change to all sub-paragraphs of 2.2.2.3	
			2.2.2.3.2	2.2.2.3.2 was 2.2.2.1.1 – typo.	
			Various	Items 27, 28, 30, 31, 32, 33, 34, 35, 42, 43, 44, 46, were 26, 27, 29, 30, 31, 32, 33, 34, 40, 41, 42, 26, respectively.	
			3.15	Added note about new handle assembly	
			3.15.1	Was 3.15, added "and discard"	
			3.15.2	Added this paragraph	
			4.0	Items 27, 28, 29, 43 & 44 were 26, 27, 29, 40, 46 respectively. Link (35) was item 34 link. Pin (32) was item 32 Pin. Lever (14) was item 14 Lever.	
			5.0	Added WL4680 - Special Troque Wrench Set for tightening hard to get at bolts.	
			6.1	Items 30, 31, 32, 33, & 34 were 29, 30, 31, 32, & 33 respectively.	
			6.1.2	Added - On older nozzles continue on to 6.1.2.1. On newer nozzles skip to 6.1.2.2.	
			6.1.2.1	Was a part of 6.1.2	
			6.1.2.2	Added	
			6.1.4	Item 33 was 32.	
			Table 1	Changed item numbers to agree with above changes. Added items 8B-8D. Revised to include new 2-piece handle.	
Figure 1	Revised item numbers for newer nozzles.				
Figure 3	Added to cover older nozzles.				

TABLE OF CONTENTS

	<u>PAGE</u>
1.0 INTRODUCTION .....	5
2.0 EQUIPMENT DESCRIPTION AND OPERATION .....	5
3.0 DISASSEMBLY.....	9
4.0 INSPECTION .....	11
5.0 SPECIAL TOOLS .....	11
6.0 REASSEMBLY .....	12
7.0 TEST.....	13
8.0 ILLUSTRATED PARTS CATALOG .....	14
FIGURE 1 64349H LATEST PRODUCTION CONFIGURATION.....	18
FIGURE 2 CONTINUITY CLIP INSTALLATION .....	19
FIGURE 3 PREVIOUS PRODUCTION CONFIGURATION .....	20

## Maintenance, Operation, Overhaul & Test Instructions Model 64349H Pressure Fueling Nozzle

### 1.0 INTRODUCTION

This manual furnishes detailed instructions covering the operation, maintenance and overhaul

of Eaton's Carter brand Model 64349H Pressure Fueling Nozzle.

## 2.0 EQUIPMENT DESCRIPTION AND OPERATION

### 2.1 DESCRIPTION

Model 64349H is a 2-1/2 inch Pressure Fueling Nozzle that has been qualified to MIL-N-5877, Rev E and listed on that QPL. The exploded view shown on page 18 includes Option H. The unit is designed to mate with adapters conforming to MS24484 or equivalent. The 64349H supersedes the previously qualified 61429AGH. The difference between the nozzles is centered around the collar-operating lever geometry and the interlock pin shape. The new collar-lever geometry improves operational safety, even with aircraft adapters worn to the limits. The change in the interlock pins improves collar wear.

prevent accidental rotation of the Collar (8) of the disengaged nozzle. Two of the three cutouts in Collar (8) are normally elongated more than the other one.

With the Collar (8) locked in the disengaged position, the flat portion of a ramp integral to the Collar (8) is positioned over a flat on the Lever (14) in a manner that prevents opening the Poppet (15).

The three Index Pins (21) mate with three slots in a serviceable MS24484 Adapter Flange to index the nozzle to the flange so the Collar (8) mates with the flange lugs during engagement and prevents disengagement of the Collar (8) from the flange without releasing the three spring loaded Collar Lock Pins (19) to the collar lock positions.

### 2.2 EQUIPMENT OPERATION

#### 2.2.1.2 LEVER/COLLAR INTERLOCK AND OVER CENTER LINKAGE

#### 2.2.1 SAFETY INTERLOCKS

It is vital that each nozzle operator understand that there are several safety interlock features designed into the 64349H Nozzle that must be functioning to prevent an accident that would result in spill of flammable liquids with the consequential risk of fire, personal injury or death, and property damage. Refer to Table 1.0 and Figures 1 and 3 to identify individual parts during the following discussion.

Examination of the center portion of the Lever (14) on a disengaged nozzle discloses the fact that a portion of the edge of the Lever (14) is beneath the flat portion of a ramp that is integral to the Collar (8). With the Collar (8) locked by the Collar Lock Pins (19), the Collar (8) ramp prevents rotation of the Lever (14) to the poppet open position. When the Collar (8) is fully engaged to a serviceable MS24484 Adapter the Collar (8) ramp clears the Lever (14) and permits Lever (14) rotation to the open position. With the Lever (14) full open, the round portion of the Lever (14) prevents rotation of the Collar (8) in the disengage direction until the Lever (14) has been fully closed. These interlocks are designed to prevent accidental opening of the poppet of a disengaged nozzle or accidentally disengaging a nozzle with the poppet open.

#### 2.2.1.1 COLLAR LOCK AND INDEX PINS

Examination of the connection end of a disengaged nozzle (nozzle not connected to an adapter) discloses the three Collar Lock Pins (19) and three Index Pins (21) installed between the Collar (8) and the Nozzle Seal (43).

The poppet operating internal linkage design is such that the linkage is over center at each extreme of travel (lever full open against internal mechanical stop or full closed against internal mechanical stop).

The three spring loaded Collar Lock Pins (19) engage three cutouts (arched shaped windows) in the flange of the Collar (8) when the Collar (8) is in the full disengaged position and these Collar Lock Pins (19)

Thus, internal pressure against a closed poppet, when the linkage is against the closed mechanical stop, provides a force only in the closed direction.

In a similar manner, with the lever in the full open/mechanical stop position, the 50 lb. force

applied by the MS24484 Adapter Poppet Spring provides a force only in the open direction.

Refer to Service Bulletin SB3480801A for the latest information on the Lever (14) as it relates to safety. As Carter or your Carter distributor for a copy if you do not have one.

## 2.2.2 OPERATION INSTRUCTIONS

### 2.2.2.1 OPERATING NOTES AND WARNINGS

The nozzle was designed to be operated in a fully open position or to be closed. No middle point is provided in the design.

**STRONG WARNING!**  
**The nozzle was not designed to be used with the operating handle in a partially open position as is the practice of some segments of the services. The handle is not a flow indicator and operating the nozzle in such manner is strongly not recommended as being a safe practice.**

**If the interlock system is worn the nozzle could be removed from the aircraft in an open position causing a spill.**

## THERMAL EXPANSION

**WARNING!**  
**Do not leave the nozzle full of fuel and in a completely closed off environment if the temperature is rising. If stored on its hose the hose will off-set some of the temperature increase. A thermal relief system should be employed if the nozzle is to be stored in such a condition.**

The nozzle is designed for operation up to and including pressures of 180 psi. (actually the nozzle will withstand and is tested to 300 psi but the military specification has a burst pressure rating of 180 psi. Burst pressure is the pressure that the nozzle can withstand without structural damage but need not be operable after being subjected to that pressure). Pressures caused by temperature changes, thermal expansion, can raise dramatically. A temperature change of just 30 degrees in a closed nozzle can raise the pressure within the unit to over 500 psi. The 30 degree temperature change can be from -10° to +20° or any other change of this magnitude. The temperature does not have to be high at all to cause the pressure to increase.

**Warning!**  
**The use of unisex couplings with a valve or any other valve on the inlet of the nozzle is not recommended and is provided only at the request of the customer. If used and the nozzle/unisex coupling is removed from the hose for storage, drain the nozzle of liquid before storing.**

### 2.2.2.2 SAFETY INSPECTIONS

Note: The frequencies recommended for the following inspections are our recommendations based on nozzles that have been in daily service for at least a year. The frequency that is required will depend upon the degree of maintenance extended to the equipment and to the age of the equipment. It is not possible for Carter to recommend other than the safest possible frequencies.

#### 2.2.2.3.1 NOZZLE INSPECTIONS - AT EACH REFUELING OPERATION

The following inspections of the Nozzle are recommended at each refueling operation:

- A. Inspect the connection end and verify that the Index Pins (21) are intact, in place, and not excessively worn or damaged. Verify that all three Collar Lock Pins (19) are intact, undamaged and are extended and engage all three cutouts in the Collar (8) and physically prevent Collar (8) rotation.

This inspection can be accomplished without interruption of the normal operating procedure and without adding appreciably to the operation time by training the operator to automatically observe the connection end of the nozzle upon disconnection from the aircraft. If the Collar Lock Pins (19) are not extended and engaged in all three cutouts in the Collar (8), the operator should squeeze the Lever (14) and Handle Grip (4) together while observing the connecting end of the nozzle. This should cause the Collar Lock Pins (19) to "spring" into the cutouts in the Collar (8). If not, then the nozzle should be taken out of service. Since the Collar Lock Pins (19) did not spring into their correct position, it could mean that the aircraft adapter (or storage adapter if used) is defective and should be inspected (see paragraph 2.2.2.3.3) and reported as possibly being defective.

- B. Upon engagement to an aircraft and opening the nozzle, but before operating the deadman control, it is recommended that the operator attempt to remove the nozzle from the aircraft. This should not be possible. If it can be removed, either the nozzle was never fully engaged onto the aircraft or needs repair, or the aircraft adapter is in need of repair.

#### **2.2.2.3.2 NOZZLE INSPECTIONS - MONTHLY BASIS**

The following inspections of the Nozzle are recommended to be conducted on a monthly basis as a minimum:

- A. Inspect the connection end and verify that the three Index Pins (21) are intact and in place. Verify that the three Collar Lock Pins (19) are intact and in place and extended and engaging all three cutouts in the Collar (8) and physically preventing Collar (8) rotation. Check the Bearing Plate (44) containing the pins for possible cracks.

- B. Hold the nozzle with the outlet or connecting end facing such that it can be observed. Apply pressure on the Collar (8) in the direction to connect the nozzle aircraft, counterclockwise, to take up the slack and inspect the relative location of the three Index Pins (19) with respect to the cutouts in the Collar (8). The two Index Pins (19) that are engaged in the normally narrower cutouts should be resting against the edge of their respective cutouts. If there is a space between one of the Index Pins (19) and the edge of the normally larger cutout the collar is still in functional condition. If all three Index Pins (19) are resting against the edge of their respective cutouts (there is no space), the Collar (8) may no longer be in a functional condition and should be replaced if it fails the next step.
- C. With the nozzle being held in the position described above, attempt to open the nozzle with the Lever (14). The nozzle should be prevented from opening by the interference between the Collar (8) and the Lever (14). If the nozzle is openable it should be removed from service and repaired.
- D. Inspect the Lever (14) and the adjacent ramp surface of the Collar (8) and verify that neither part is damaged or has missing pieces that permit the Lever (14) to be rotated to the open position with the nozzle disengaged, or that will allow the Collar (8) to rotate to the disengaged position when the Lever (14) is open. Broken or missing parts can result in dangerous fuel spills while refueling aircraft.
- E. Verify that the Lever (14) is in the fully closed (against internal mechanical stop) position. (This is necessary to assure that the linkage is over center so internal pressure can not force the poppet open during the Collar (8) engagement).

#### **2.2.2.3.3 AIRCRAFT ADAPTER INSPECTIONS**

The following inspections of the aircraft adapter are recommended to be carried out at each refueling operation to assure that one is connecting to a safe adapter:

- A. Visually check for bent, broken, missing or excessively worn lugs or slots. Worn slots are easily detected. A normal slot will have a slight machine broken edge [chamfer of .030 inch (0.762 mm)]. If the edge is worn such that the corner is badly distorted and enlarged it should be inspected more closely and accurately. Carter Adapter Wear Gauge, 61657-2, should be utilized to check the width and thickness of the lugs if they appear to be worn. Wear of the

thickness dimension of the lug will promote premature nose seal leakage. Wear of the width of the lug combines with slot wear in defeating the nozzle interlock.

- B. Visually check the three slots for excessive wear. Excessive wear can permit disengagement of a nozzle without release of the three Collar Lock Pins (19) and may permit accidental poppet opening on the disconnected nozzle. The use of Carter Gauge 61657-2 will provide a "no-go" check for the slots.
- C. If any of the above conditions are observed, and or the gauge proves the adapter to be defective, the refueling operation should be continued only with extreme caution. The nozzle, upon disconnection, should be checked in accordance with paragraph 2.2.2.3.1.A. The suspected defective adapter should also be reported to the appropriate personnel.

#### 2.2.2.4 NOZZLE CONNECTION

After completion of the Safety Inspections of 2.2.2.3, connect the nozzle as follows:

- A. With the Cover (1) removed, grasp the nozzle by the Collar (8) handle grips and align the connection end with the aircraft adapter.
- B. Press the nozzle against the adapter while slightly rotating the nozzle (if necessary) to align the Nozzle Index Pins (21) with the adapter slots.
- C. With the nozzle aligned, press the nozzle against the adapter flange until the Collar Lock Pins (19) are depressed sufficiently to permit rotation of the Collar (8) in the clockwise direction until the Collar (8) is fully engaged against a mechanical stop (approximately 30 degrees of collar rotation).
- D. With the Collar (8) fully engaged and stopped, rotate the Lever (14) in the open direction to the **full open linkage over center position** against the internal mechanical stop (approximately 200 degrees) of the Lever (14) rotation. Note: If the Lever (14) is not rotated against the full open stop, the 50 pound adapter poppet spring force may move the nozzle poppet to a partially closed

position which will unnecessarily increase the time required to refuel the aircraft and cause unnecessary wear of both the nozzle and the aircraft adapter. If Lever (14) movement is observed during fuel flow, the Lever (14) was not in the full open over center.

**Caution:**  
**Lever rotation to an intermediate position is unsafe and can result in a flowing disconnect and dangerous fuel spill.**

- E. Prior to commencing fuel flow, verify that the round portion of the Lever (14) prevents rotation of the Collar (8) to the disengaged position.

#### 2.2.2.5 NOZZLE DISCONNECTION

Upon completion of refueling operations, disconnect the nozzle as follows:

- A. Rotate the Lever (14) in the closed direction until it is against the internal mechanical stop (approximately 200~210 degrees).

**CAUTION:**  
**If the Lever (14) is not against the internal closed stop. The linkage is not over center and internal pressure will force the poppet in the open direction.**

- B. With the Lever (14) full closed, grasp the Collar (8) handles and rotate the Collar (8) counter-clockwise until the nozzle is released from the adapter (approximately 30 - 35 degrees). Examine the connection end of the nozzle and verify that all three Collar Lock Pins (19) have been released into the cutouts in the Collar (8) flange to securely lock the Collar (8).
- C. Examine the connection end of the nozzle and verify that all three Collar Lock Pins (19) have been released into the cutouts in the Collar (8) flange to securely lock the Collar (8).



**Caution:**

**If a worn adapter has allowed disengagement of the nozzle without release of all three Pins (19), rotate the collar in the disengage direction until all pins are released to lock the collar. (This condition caused by a damaged adapter on one aircraft resulted in a dangerous fuel spill during attempted refueling of a second aircraft). Reinspect the adapter of the serviced aircraft and replace if worn.**

- D. Replace the Cover (1) and return the nozzle to the normal storage location.

---



---

### **3.0 DISASSEMBLY**

- 3.1.1** Remove nozzle from end of hose and quick disconnect.

NOTE: To assist in disassembly, the flange from an MS24484 adapter or Carter part number S204451, is required. Do not engage adapter in nozzle collar until ball bearing removal of paragraph 3.4 has been completed.

- 3.2** If Cover (1) or Grip (4) replacement is required, remove Cover (1) from nozzle by removing the appropriate Screw (2) and Washer (3). Screw (2) should be removed with a torque wrench and the removal torque measured. This screw is a self-locking type and is designed to be reused several times before losing its locking capability. If the torque is less than 6.5 in-lb. discard it and replace it during reassembly.
- 3.3** Remove Collar Bumper (6) by cutting through the bumper only if required to replace.
- 3.4** Screw (7) is a self-locking type screw that utilizes a nylon insert in the threads to affect the resistance required to provide the locking. It is designed to be reused several times before losing its locking effectively. Using a torque wrench, remove Screw (7), measuring the torque during removal. If the torque is less than 9.5 in lb. (0.11 m kg) discard the screw and replace it with a new one during reassembly. Carter Ball Removal Tool, 61607, is designed to assist in removing and counting the Balls (10) used in this joint. Screw the tool in the hole where Screw (7) was removed. Hold the nozzle such that the tool is below the nozzle and rotate the Body (9) until all Balls (10) have been removed. The number of Balls (10) should be such that the last one should line

up just below the cotter pin hole in the tool. If the tool is not used, hold bolt hole vertical (pointed down) and allow all Balls (10) to be removed through the bolt hole. Catch all balls in a container. Rotation between Collar (8) and body (9) will be required to allow 49 Balls (10) to fall out of hole.

- 3.5** Engage nozzle to the flange of an MS24484 adapter or Carter S204451.
- 3.6** Remove Nozzle Collar (8) from Body Assembly (9) by aligning the groove in the Collar (8) with detent on Body (9) and pull body from collar.
- 3.7** Remove MS24484 Adapter or S204451 Flange.
- 3.8** Turn Lever (14) to open Poppet (15).
- 3.9** Remove Cotter Pin (16) and unscrew the Poppet (15) from the Shaft (33). Observe the Poppet (15) for presence of any loose pieces. Older nozzles had a flow diverting shroud present that was pressed into place on the backside of the poppet. If it is present and firmly in place, leave it in place. If it loose remove it completely and discard it. It is no longer needed.
- 3.10** The Nozzle Seal Assembly (42) may be removed by lifting off Body (9). The Plate (44) may be removed from the Seal (43) by spreading the ends of the Retaining Ring (45), removing it from the groove in the Seal (43) and then sliding the Plate (44) off the Seal (43).
- 3.11** The three Lock Pins (19), three Lock Pin Springs (20), three Index Pins (21) and O-Ring (18) may now be removed.
- 3.12** Remove Plugs (22) only if a leak is observed or the nozzle is identified as an older version requiring the removal of a plug to access the

Lever (14) as noted below. NOTE: Use new Teflon tape on reinstallation. Do not utilize more than 1 1/2 wraps of tape. Excessive use of tape could lead to the cracking of the Body (9).

- 3.13** Remove screw (23), using a torque wrench as noted in paragraph 3.4 and discard O-ring (24). Remove the 39 Balls (11) in the same manner as described in paragraph 3.4. The 39 Balls (11) will automatically be counted in the removal tool. The last ball should line up with the line etched in the tube of the tool.
- 3.14** On newer nozzles, remove Elbow Assembly (25A) or (25) on older ones. Remove and discard Seal (27) and O-ring (28) if replacement is needed. **Seals (27) and (28) need not be removed unless replacement is needed.** If Clip (12) is to be replaced, used a pair of needle nose pliers to grasp the existing part and pull it from the hole in the Body (9). Clear the hole of any debris. Inspect Wear Ring (26) ,where present, for worn spots. Remove and discard if worn spots are present.
- 3.15** Hold the nozzle outlet in an “up” position as you would if the aircraft adapter were underwing. View Lever (14) to determine the age of the lever. Two older versions, both gray in color, were produced, one with a operating lever that is clocked in the 6 o'clock position when closed and the other with the lever clocked in the 3 o'clock position when closed. The newer lever is black, clocked at 6 o'clock and is retained by a single screw through the middle of the lever. Note: If a gray handle retained by a single screw is present replace it with a new black handle. Proceed to 3.15.1 if either of the older levers is present, other wise proceed to 3.15.2.
- 3.15.1** On older nozzles the operating Lever (14) was retained by four internally mounted Screws (35). To continue to disassemble these nozzles continue on with this paragraph.

- 3.15.2** Remove Screws (35) through plug opening (22). Observe the orientation of the Plate (36) with respect to the Lever (14) such that it can be duplicated during reassembly. Mis-orientation will result in not being able to close the nozzle properly.

Remove Lever (14) from body (9). Remove and discard Seal (37) and Backup Ring (38) from Lever (14).

Remove assembled Shaft (32), Pin (33), Link (34) and Plate (36) with attaching parts from Body (9). Remove Pin (33). Disassemble Cotter Pin (29), Nut (30) and Crank Pin (31) only if replacement is necessary.

- 3.15.3** On newer nozzles serial number 6520 and subsequent the Lever (14) is retained by a single screw in the middle of the shaft portion of the lever.

Remove Screw (39), Washer (40) and O-ring (41). Discard Screw (39) and O-ring (41).

Pull Lever (14) from Body (9) and remove and discard Seal (37) and Backup (38).

Remove assembled Shaft (33), Pin (34), Link (35) and Plate (36) from Body (9).

Remove Cotter Pin (30), Nut (31) and Crank Pin (32) only if replacement is necessary. The Wave Washers (35A) should be replaced if the lever has not been staying in the open position while flow is occurring.

#### 4.0 INSPECTION

Replace the following items with new parts from kit KD64349-1 during maintenance:

ITEM NO.	PART NO.	DESCRIPTION	QTY
7,23	220484	Screw	2
12	209853	Clip, continuity	1
18	M25988/1-145	O-ring	1
24	MS29512-03	O-ring (Newer nozzles) (Note 3)	1
	MS29513-013	O-ring (Older nozzles) (Note 3)	1
27	207807	Seal	1
28	M25988/1-040	O-ring	1
29	M25988/1-235	O-ring	1
37	207792	O-ring, Teflon coated	1
38	MS28774-017	Backup Ring	1
39	GF16697-69	Screw	1
41	MS29513-010	O-ring	1
43	209029	Seal Nose	1
46	GF24665-302	Cotter Pin	1

Inspect all metal parts for dings, gouges, abrasions, etc. Use 320 grit paper to smooth and remove sharp edges. Replace any part with damage exceeding 15% of local wall thickness. Use alodine 1200 to touch up bared aluminum.

Precisely measure the following items. Replace any part that exceeds the identified maximum or minimum wear limits:

- Both holes in Link (35) [.196 inch (4.98 mm) diameter maximum & .320 inch (8.13 mm) diameter maximum].
- Bearing diameter of Pin (32) [.300 inch (7.62) diameter minimum].
- Tapered bearing diameter of Lever (14) [.697 inch (17.7 mm diameter minimum on larger end and .635 inch (16.1 mm) diameter minimum on small end].
- The diameter of the Wear Ring (26) shall not be less than 0.075" at any place along the item. Replace if this is the case.
- Examine the Lever (14) for cracks. Also examine the fit between the Lever (14) "teeth" and the Crank (36) "teeth" by placing the two parts together and attempting to rotate them against each other. The fit should be snug and not loose. Replace both parts if looseness appears to be present. Do not replace only one part.

#### 5.0 SPECIAL TOOLS

The following special tools are recommended for proper repair and or overhaul of the nozzle:

- S204451 - Standard three lug bayonet adapter flange or equivalent.
- 6958CG or 6958CH Adapter or equivalent.
- 61657-2 Adapter Wear Gauge.
- 61607 Ball Removal Tool
- 64000 Poppet Adjustment Gauge.
- WL4680 - Special Troque Wrench Set for tightening hard to get at bolts.

## 6.0 REASSEMBLY

- 6.1** Reassemble in reverse order of disassembly (Refer to Figure 1), observing the following:
- 6.1.1** Make certain all components are clean and free from oil, grease, or any other corrosion resistant compound on all interior or exterior surfaces. Wash all parts with cleaning solvent and dry thoroughly with a clean, lint-free cloth or compressed air.

### **WARNING**

**Use cleaning solvent in a well-ventilated area. Avoid breathing of fumes and excessive solvent contact with skin. Keep away from open flame.**

**DO NOT** use any form of grease on Balls (10) or (11) and be certain to install proper number of balls in each hole of the body and collar assembly. Also make certain Clip (12) is installed properly to maintain continuity through unit. See Figure 2.

Note: A light coat of petrolatum, Federal Specification VV-P-236, can be applied to all gaskets, springs, and screws for ease of installation.

- 6.1.2** If Cotter (29) or (30) (older versus newer models, see Figures 1 & 3) and Nut (30) or (31) were removed during disassembly, torque Nut (30) or (31) to 80-125 in lb. to align slots in nut with hole in Crank Pin (31) or (32).

When reinserting the sub-assembled parts noted in Paragraph 3.17 of the disassembly procedure, through the inlet end of the Body (9) ensure that the Shaft (33) is inserted into the Body's (9) axial guide bore far enough that the bore contains the Dowel Pin (34). On older nozzles continue on to 6.1.2.1. On newer nozzles skip to 6.1.2.2.

### **WARNING**

**Do not use Crank Pin (31) from the older models on the newer units where the Lever (14) is used. Crank Pin (31) is too short and damage to the pin may occur.**

lubricating both lightly. Insert Handle (14) into Body (9). **Assure that the orientation of the Plate (36) to the Lever (14) is as observed prior to disassembly.** Use the 9/64 inch Allen wrench through the Body's (9) pipe thread port to secure the Plate (36) to the end of the Lever (14) shaft with the four socket head Screws (35). Torque each of the Screws (35) to 16 to 18 inch pounds

Reinstall the Plug (22). **NOTE:** cludes a sealant and the use of Teflon tape is not required. If new Teflon tape is used on reinstallation. Do not utilize more than 1 1/2 wraps of tape. Excessive use of tape could lead to the cracking of the Body (9).

- 6.1.2.2** On newer nozzles – Install O-ring (38) and Backup (37) onto the Handle (14), lubricating both lightly. Insert Handle (14) into Body (9). Orientate the Handle (14) properly such that it is approximately at the “3” o'clock position when the nozzle is in the closed position and in the “9” o'clock position when the nozzle is closed (3 o'clock when opened) and retain with Screw (39), Washer (40) and O-ring (41). Torque the Screw (39) in the outer portion of the Lever (14) to 125 ± 5 inch pounds, loosen the Screw (39) and retorque to 125 ± 5 inch pounds.

- 6.1.3** If Clip (12) is to be installed, refer to Figures 2A and 2C for correct installation. The straight leg of the part is to be pressed into the hole in the Body (9) using a pair of needle nose pliers as shown in Figure 2B. It is important that the Clip (12) be fully installed into the hole such that it lies as shown in Figure 2C.

Install the Inlet (25) at the end of the assembly procedure. Use care in installing inlet (25) so Seal (27) is not cut. Be sure to install Clip (12) first.

- 6.1.2.1** On older nozzles - Install O-ring (38) and Backup (37) onto the Handle (14),

**Maintenance Tip:**

**Should it be desired to be able to change the nose seal of the nozzle without a major disassembly of the unit it is possible to do by eliminating Snap Ring (45). One word of caution should this be done. If the nozzle is opened with a tool that does not have the characteristic lugs of an adapter, the nose seal may follow the poppet open and be difficult to reinstall without disassembly. The Snap Ring (45) will continue to be installed by the factory. When the nose seal is to be replaced, please refer to the Caution Note in paragraph 3.9.1 before proceeding.**

**6.1.4** Using the MS24484 Flange (S204451) rotate Lever (14) to the open position to extend Shaft (33) to its fullest open position. Screw Poppet (15) onto the Shaft (33) such that the hole in the Shaft (33) is approximately centered in the slotted area of the Poppet (15). With the Poppet (15) closed disengage the Collar (8) from the MS24484 adapter Flange (S204451) and set the nozzle on its inlet end. Note: If the Poppet (15) is difficult to close, reopen the unit and loosen the Poppet one half a turn until the nozzle closes. Use Poppet Adjustment Gauge, 64000, to facilitate the adjustment of the Poppet (15) onto the Shaft (33). If the gauge is not used, place a straight edge across the center of the

elastomer lip of the Seal (43). Use feeler gages to measure the average dimension between the bottom of the straight edge and the Poppet (15) face. This dimension should be .070 to .110 inch (1.8 to 2.8 mm). If it is not, calculate the required poppet dimension as follows: (one quarter (1/4) turn of the Poppet (15) axially displaces the Poppet (15) face about .020 inch (0.51 mm).

- A) If the feeler gage measurement is too long, prepare to unscrew (loosen) the Poppet (15) one quarter (1/4) turn for each .020 (0.51 mm) inch of required adjustment.
- B) If the measurement is too short, prepare to tighten the Poppet (15) one quarter (1/4) turn for each .020 (0.51 mm) inch of required adjustment.

Once the proper Poppet (15) adjustment is made, rotate the Poppet (15) toward the tightening direction until the next slot in the Poppet (15) is in line with the hole in the Shaft (33). Insert the Pin (16) and bend over the ends to retain in place. It is important that both legs of the pin be bent properly.

**6.1.5** Install the Grip (4) using Screw (2) and Washer (3) being sure to replace Cover (1) onto one Handle (5) before the Grip (4) is installed.

**6.1.6** If Bumper (6) is to be replaced onto Collar (8) warm Bumper (6) in water at 160-180° F to soften before pressing onto Collar (8).

**7.0 TEST**

**7.1** The following test procedures will be accomplished after overhaul:

**7.2 Test conditions**

**7.2.1** Test media shall be Stoddard Solvent, JP-4 at 75° ± 15° F, Jet A or equivalent.

**7.3 Functional Test**

**7.3.1** The nozzle shall be inserted and locked into a test adapter (MS24484 or equivalent) which is mounted in a sealed housing and the nozzle valve actuated by use of the crank lever from the fully closed to fully open position a minimum of five times. There shall be no evidence of binding or excessive force required for valve actuation.

**7.4 Leakage Test**

**7.4.1** With the nozzle outlet in the normal open position, pressurize the inlet to five psig and hold for one minute minimum. There shall be no evidence of external leakage from the nozzle.

**7.4.2** Repeat the leakage test at 60 psig and 120 psig.

**7.4.3** Close and disengage the nozzle and repeat 7.4.1 and 7.4.2.

**7.5 Continuity Test**

**7.5.1** With the nozzle still in the functional test setup (7.3.1) measure the resistance (OHMS) between the adapter mounting flange and the inlet flange of the nozzle. The resistance

from the nozzle inlet flange to the adapter

mounting flange shall be less than 10 OHMS.

**8.0 ILLUSTRATED PARTS CATALOG**

Table 1.0 tabulates the parts and sub-assemblies comprising the 64349H Pressure Fueling Nozzle. The item numbers of the

table are keyed to the exploded views of the nozzles diagrammed in Figure 1 and 3.

**TABLE 1.0  
Current Production Nozzle Configuration (Figure 1)**

<b>Fig. No.</b>	<b>Item</b>	<b>Part Number</b>	<b>Description</b>	<b>Units Per Assembly</b>	<b>NSN</b>
1	1	207799	Cover .....	1	5340-01-246-2706
	2	GF16997-78L	Cap Screw .....	2	5305-01-189-3761
	3	GF960-516	Washer.....	2	5310-00-167-0820
	4	207808	Grip .....	2	5340-01-324-0954
	5	210600	Handle .....	2	5340-01-415-1292
	6	23622	Bumper .....	1	4930-00-848-1310
	7	220484	Screw, Pan Head.....	1	5305-01-246-3868
	8	220269	Collar.....	1	4930-01-385-9453
	8B	GF4-13A	Screw.....	2	
	8C	GF960-416	Washer.....	2	
	8D	GF21042-4	Nut.....	2	
	9	207784	Body .....	1	4930-01-244-8043
	10	221075	Bearing, Ball.....	49	3110-01-247-1056
	11	221075	Bearing, Ball.....	39	3110-01-247-1056
	12		Left intentionally blank		
	13		Left intentionally blank		
	14	220878-1	On/Off Act. Lever (Note 2) .....	1	
	15	210593	Poppet.....	1	4820-01-252-3725
16	GF24665-302	Pin, Cotter .....	1	5315-00-234-1864	
17		Left intentionally blank			
18	M25988/1-145	O-ring .....	1	5330-01-010-2419	
1	19	220272	Pin, Collar Lock .....	3	5315-01-385-5535
	20	20909	Spring, Collar Lock Pin.....	3	5360-00-155-5099
	21	24780	Pin, Indexing .....	3	4930-01-053-0194
	22	210388	Plug .....	2	4730-01-198-9551
	23	220484	Screw, Pan Head.....	1	5305-01-246-3868
	24	MS29512-03	O-ring (Note 3).....	1	

Fig. No.	Item	Part Number	Description	Units Per Assembly	NSN
	25B	44327	Inlet Elbow Assembly.....	1	
	25A	47264	Inlet Elbow Assembly.....	1	
	25	221125	Inlet Elbow (Note 4).....	1	
	26	220894	Ring, Wear (Note 4).....	1	
	27	207807	Seal.....	1	5330-01-247-1080
	28	M25988-040	O-ring.....	1	5330-01-244-2274
	29	M25988/1-235	O-ring.....	1	5330-01-007-4899
	30	GF24665-1013	Pin, Cotter.....	1	5315-01-025-4510
	31	GF320C4	Nut, Castellated.....	1	5310-00-721-4434
	32	220886	Pin, Crank (Note 2).....	1	
	33	210368	Shaft.....	1	3040-01-385-8986
	34	D9-437	Dowel Pin.....	1	5315-01-341-8766
	35	207795	Link.....	1	
	35A	5806-21-3	Wave Washer.....	2	
	36	220878-3	Crank (Note 2).....	1	
	37	207792	O-ring, TFE Coated.....	1	5330-01-246-7351
	38	MS28774-017	Back-up.....	1	5330-00-833-4210
	39	GF16697-69	Screw (Note 2).....	1	
	40	5710-54-60	Washer (Note 2).....	1	
	41	MS29513-010	O-ring (Note 2).....	1	
	42	47058	Nose, Seal Assy.....	1	4930-01-385-9488
	43	209029	Seal, Nozzle.....	1	5330-01-264-0134
	44	220271	Plate, Bearing.....	1	3110-01-385-3438
	45	24636	Ring, Snap.....	1	5340-01-053-0192
	--	KD64349-1	Kit Maintenance (consists of the following items: 7, 12, 16, 18, 23, 24, 27, 28, 37, 38, 39, 41 & 43 from above.)		4930-01-385-9025 (Note 5)
	--	KD64349-2	Kit, Overhaul (consists of the following items: 1, 4, 5, 14, 15, 19, 20, 21, 29, 32, 35A, 36, 39 & 40.) (Note 2)		4930-01-385-9083 (Note 5)
	--	KD64348-12	Kit - contains all parts needed to change from a single piece 220270 or 220561 Handle to the newer two piece handle. - Contains items 14, 24, 30, 32, 35A and 36-41. (Note 2)		

TABLE 2.0  
Previous Nozzle Configuration (Figure 3)

Fig. No.	Item	Part Number	Description	Units Per Assembly	NSN
3	1	207799	Cover .....	1	5340-01-246-2706
	2	GF16997-78L	Cap Screw .....	2	5305-01-189-3761
	3	GF960-416	Washer.....	2	5310-00-167-0820
	4	207808	Grip .....	2	5340-01-324-0954
	5	210600	Handle .....	2	5340-01-415-1292
	6	23622	Bumper.....	1	4930-00-848-1310
	7	220484	Screw, Pan Head (Newer models) (Note 3) .....	1	5305-01-246-3868
		209827	Screw (Older models) (Note 3) .....	1	
	8	220269	Collar.....	1	4930-01-385-9453
	8B	GF4-13A	Screw.....	2	
	8C	GF960-416	Washer.....	2	
	8D	GF21042-4	Nut.....	2	
	3	9	207784	Body.....	1
10		221075	Bearing, Ball.....	49	3110-01-247-1056
11		221075	Bearing, Ball.....	39	3110-01-247-1056
12		209853	Clip.....	1	
13			Left intentionally blank		
14A		220270	On/Off Act. Lever (Old Lever) (Note 2) .....	1	3040-01-385-9064
14B		220561	On/Off Act. Lever (Old Lever) (Note 2) .....	1	
15		210593	Poppet.....	1	4820-01-252-3725
16		GF24665-302	Pin, Cotter .....	1	5315-00-234-1864
17			Left intentionally blank		
3	18	M25988/1-145	O-ring .....	1	5330-01-010-2419
	19	220272	Pin, Collar Lock .....	3	5315-01-385-5535
	20	20909	Spring, Collar Lock Pin.....	3	5360-00-155-5099
	21	24780	Pin, Indexing .....	3	4930-01-053-0194
	22	210388	Plug .....	2	4730-01-198-9551
	23	220484	Screw, Pan Head (Newer models) (Note 3) .....	1	5305-01-246-3868
		209827	Screw (Older models) (Note 3) .....	1	
	24	MS29512-03	Gasket (Newer models) (Note 3).....	1	
		MS29513-013	O-ring (All older units) (Note 3) .....	1	5330-00-248-3828
	25	207873	Inlet Elbow .....	1	4730-01-265-3145
26	207807	Seal.....	1	5330-01-247-1080	
27	M25988-040	O-ring .....	1	5330-01-244-2274	



Fig. No.	Item	Part Number	Description	Units Per Assembly	NSN
	28	M25988/1-235	O-ring .....	1	5330-01-007-4899
	29	GF24665-1013	Pin, Cotter.....	1	5315-01-025-4510
	30	GF320C4	Nut, Castellated .....	1	5310-00-721-4434
	31	207788	Pin (Note 2).....	1	
	32	210368	Shaft .....	1	3040-01-385-8986
	33	D9-437	Dowel Pin.....	1	5315-01-341-8766
	34	207795	Link .....	1	
	35	LP65U82J12M	Screw (Note 2).....	4	5305-01-413-0746
		GF16995-28	Screw (Older models) (Note 2)(Replaced by LP65U82J12M in later units).....	4	
	36	207783	Plate (Note 2) .....	1	
	37	207792	O-ring, TFE Coated.....	1	5330-01-246-7351
	38	MS28774-017	Back-up .....	1	5330-00-833-4210
	42	47058	Nose, Seal Assy .....	1	4930-01-385-9488
	43	209029	Seal, Nozzle.....	1	5330-01-264-0134
	44	220271	Plate, Bearing .....	1	3110-01-385-3438
	45	24636	Ring, Snap .....	1	5340-01-053-0192

- Note:
1. All part numbers beginning with "GF" are interchangeable with those beginning with either "AN" or "MS". If the "GF" is followed by three numbers, it is interchangeable with an "AN" part, otherwise it is interchangeable with an "MS" part of the same number.
  2. There have been three item 14 On/Off Actuating Levers used on the 64349 Nozzle. Item 14, replaces the previously used items 14A and 14B. Several other parts are needed to replace (14A) or (14B) and are furnished with KD64349-2 and KD64348-12. Neither (14A) or (14B) are available, they will automatically be replaced by KD64348-12.
  3. The MS29512-03 O-ring (24) is used with Screw (23) 220484. This is available as an assembly (and is more economical to order as such) as part number KDT-1191. If Screw (23) 209827 is to be replaced do so with KDT-1191. O-ring (24) MS29513-013 is used with the older Screw (23) 209827 only.
  4. Item (26), Wear Ring, has been included as a design improvement in newer versions of the nozzle to improve the life of the swivel. Older Elbows (25) without the Wear Ring (26) are fully interchangeable with the newer ones. The older Elbow (25) in Figure 3 is no longer available for procurement. When ordered item (25) from Figure 1 will be supplied.
  5. Contents of these kits have changed in the past year hence kits in the stock system may be different than the contents listed.

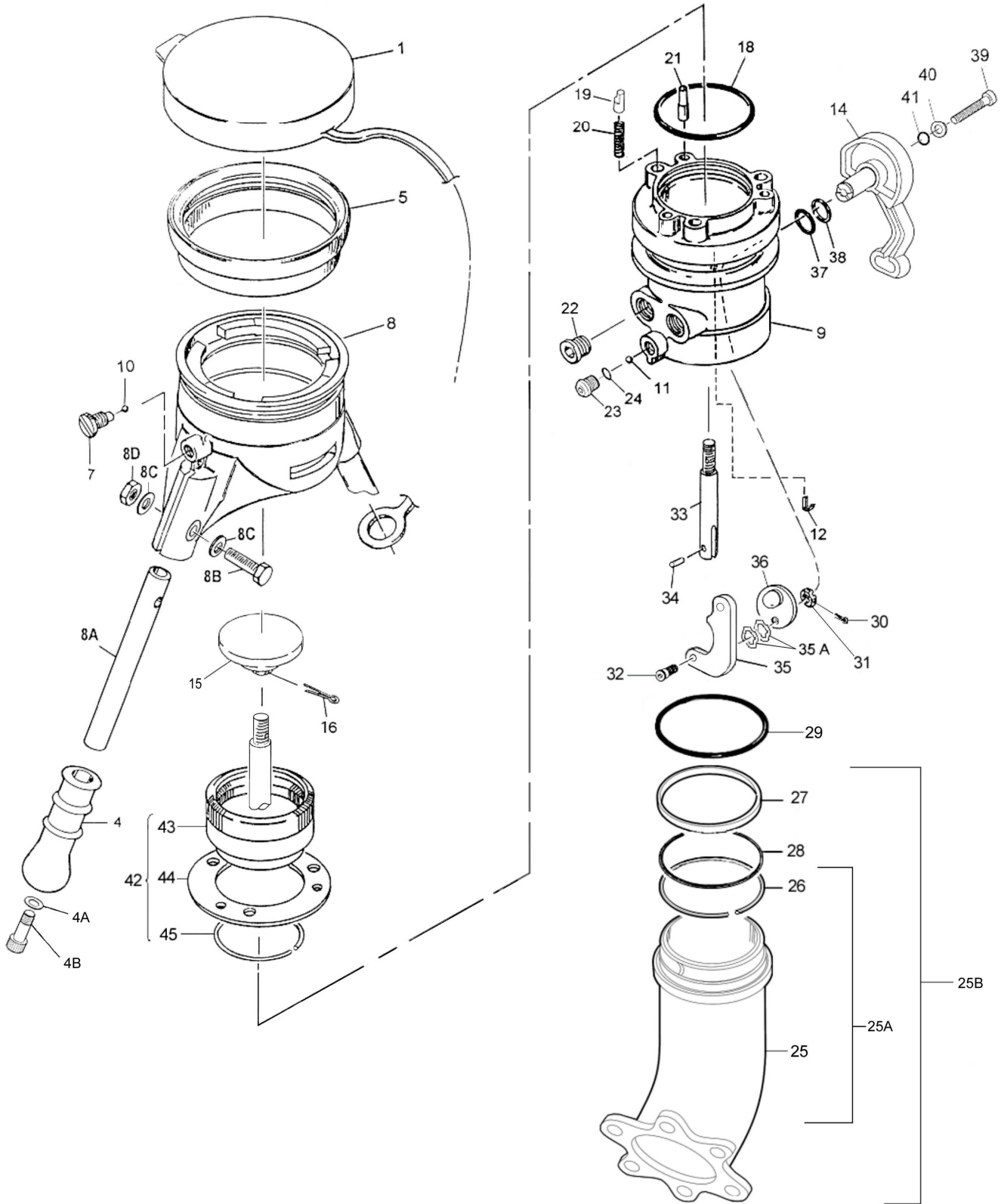

FIGURE 1  
64349H Latest Production Configuration

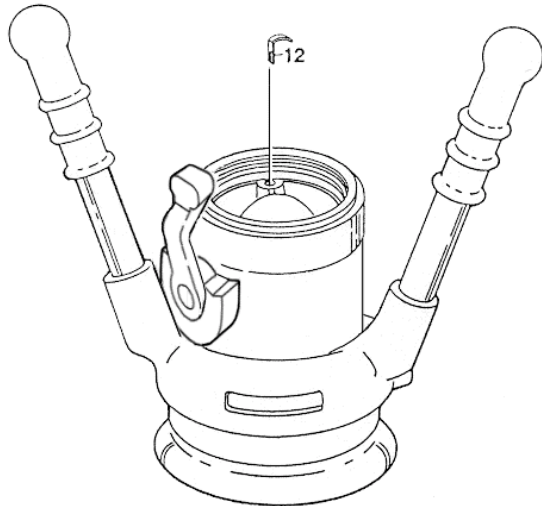

FIG. 2A  
CONTINUITY CLIP INSTALLATION (12)

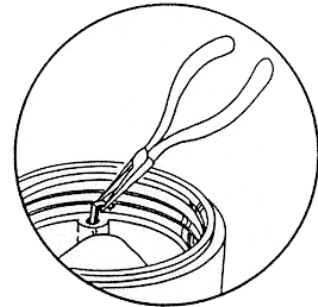

FIG. 2B  
REMOVING CLIP (12)

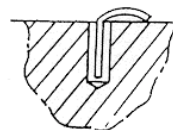
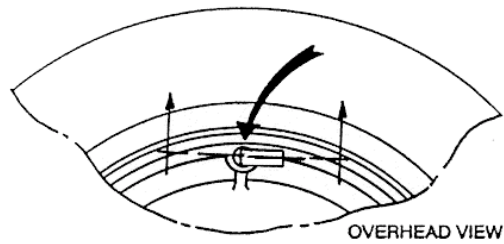

FIG. 2C  
CORRECT CLIP INSTALLATION (12)

FIGURE 2  
Continuity Clip Installation

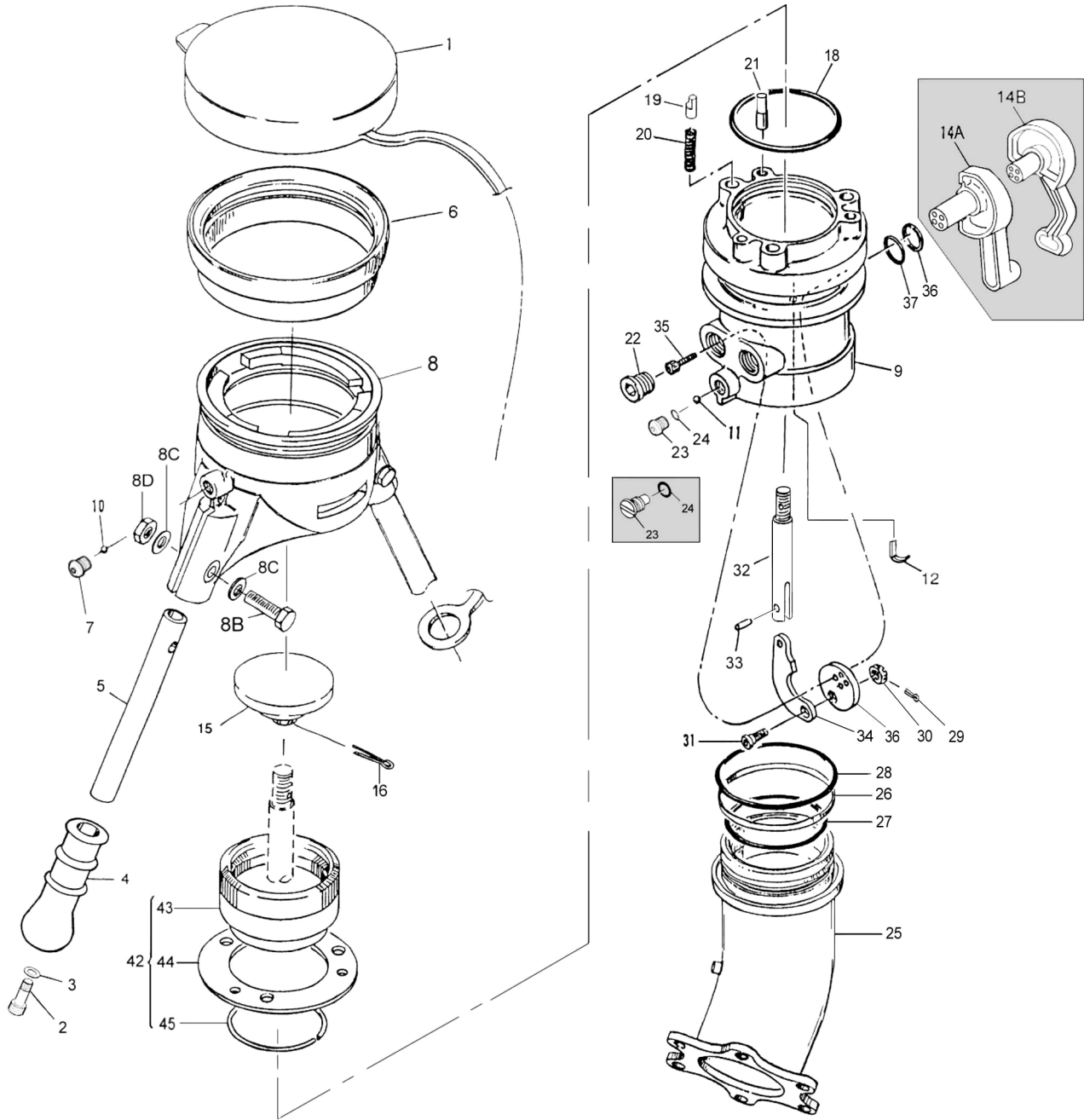

FIGURE 3  
Previous Production Configurations of 64349H

Aerospace Group  
 Conveyance Systems Division  
 9650 Jeronimo Rd  
 Irvine, CA 92618  
 Ph (949) 452-9500  
 Fax (949) 452-9992