



Powering Business Worldwide

Eaton
Aerospace Group
Fluid & Electrical Distribution Division

Carter®
Ground Fueling Equipment

SM349MISC

May 2013

Applicable additional manuals:

SM64349 – Model 64349 Nozzle
SM64201 – Model 64201 Nozzle
SM61429ACDGK – Model 61429ACDGK Nozzle
SM61429AGH – Model 61429AGH Nozzle
SM61429AGJ – Model 61429AGJ Nozzle
SM64349CDK – Model 64349AGJ Nozzle
SM64349H – Model 64349H Nozzle
SM64349J – Model 64349J Nozzle

Maintenance Manual

Misc. Accessories to Mate Carter® Model 64349 and Model 64201 Nozzles

Table of Contents

	Page
1.0 INTRODUCTION.....	3
2.0 EQUIPMENT DESCRIPTION	3
3.0 DISASSEMBLY	3
4.0 INSPECTION & SPECIAL TOOLS.....	5
5.0 REASSEMBLY	5
6.0 TEST	6
7.0 ILLUSTRATED PARTS CATALOG.....	6
FIGURE 1	8
FIGURE 2.....	8
FIGURE 3.....	9
FIGURE 4.....	10
FIGURE 5.....	10
FIGURE 6.....	11
FIGURE 7.....	11
FIGURE 8.....	12

Maintenance, Overhaul & Test Instructions

Miscellaneous Carter Male Half Adapters

1.0 INTRODUCTION

This manual furnishes detailed instructions covering the maintenance and overhaul of various Eaton's Carter ground fueling equipment product

line accessories designed to mate Carter Models 61429, 64349, and 64201 military nozzles that are not covered by other service manuals.

2.0 EQUIPMENT DESCRIPTION

The various inlet adapters listed below are used on the Carter Models 61429, 64349, and 64201 military nozzles to complete the nozzle in various configurations.

Newer nozzles have been revised to include a wear ring on all of the male swivel joint parts.

Part no.	Description
44327	Option H Elbow (D-1)
44326	Option J Inlet (D-2)
44325	Option K Inlet
47566	Option N Inlet
44771	Option S Inlet
47063	Option W Inlet
43045-1	Option 2 Male Adapter
44362	Option 9 Male Adapter

This manual should be utilized in conjunction with other appropriate manuals when servicing any 61429, 64349, and 64201 nozzles. There are specific manuals provided for the following six types of military nozzles:

Nozzle	Manual no.
64201	SM64201
64349H	SM64349H
64349J	SM64349J
64349CDK	SM64349CDK
61429AGH	SM61429AGH
61429AGJ	SM61429AGJ
61429ACD GK	SM61429ACD GK

Download these manuals from www.argo-tech.com, or request them directly from Carter or from your nearest Carter distributor. They are free of charge.

3.0 DISASSEMBLY

3.1 Remove the adapter assembly from the nozzle following the appropriate instructions in SM64201, SM61429 or SM64349 as appropriate. Skip to the paragraph that covers the particular adapter.

3.2 **44326 - D-2 Nozzle Inlet Adapter- Option J** (see Fig. 1) - The Teflon Seal (4) and O-ring (3) should only be removed if the Seal (4) is damaged. The O-ring (3) is a fluoro-silicone compound and is not affected by age. To remove it use an "O-ring pick" being careful not to damage the Adapter (2). Once removed, the Seal (4) must be replaced as well as the O-ring (3).

Newer nozzles will have an Outer Wear ring (5) installed on the ball groove. Older nozzles will not have this item. If present, inspect the Outer Wear Ring (5); remove if necessary, for wear or damage. If not worn then leave it in place.

3.3 **44327 - D-1 Nozzle Inlet Adapter – Option 2** (see Fig. 2). The Teflon Seal (4) and O-ring (3) should only be removed if the Seal (4) is damaged. The O-ring (3) is a fluoro-silicone compound and is not affected by age. To remove it use an "O-ring pick" being careful not to damage the Adapter (7). Once removed, the Seal (4) must be replaced as well as the O-ring (3).

Newer nozzles will have an Outer Wear ring (5) installed on the ball groove. Older nozzles will not have this item. If present, inspect the Outer Wear Ring (5); remove if necessary, for wear or damage. If not worn then leave it in place.

3.4 **44325 - 2" Female Camlock Inlet - Option K** (see Fig. 3), with Quick Disconnect and 100-mesh Screen.

- Do not remove camlock Coupling (23) from unit unless it needs replacing or there is leakage at the joint between the Coupling (23) and the Housing (15).
- Remove Lockwire (12) from Screws (13). Take note of the method of lockwiring for duplication upon reassembly.
- Remove Screws (13) and Washers (14) and set aside.
- Holding the unit with the camlock end in the right hand and the adapter end in the left, pull the black plastic Retainer (19) away from the Housing (15). Rotate the Housing in either direction and pull it away from the Adapter (18) to disassemble.
- Remove the Quad Ring (16) from the Housing (15). (Older units may have a two piece seal consisting of a plastic seal and a spring that is mounted inside the seal cavity. These two parts may be replaced with the Quad Ring (16).) Do not remove the Wave Washer (17) unless it is to be replaced. This washer is used to assure electrical continuity between the Housing (15) and Adapter (18). If it is necessary to remove the Washer (17) it can only be accomplished by bending it out of shape. The Washer (17) is intended to be "wavy" and the precision of the waves are of no consequence as

long as the waves are sufficient to make contact between the male and female halves of the Swivel.

- If a Screen (11) is present it may be removed for replacement or cleaning by removing its Retainer (10) first.
- The removal of the Curved Washer (20), Shroud (21), noting the direction in which it is installed for use in reassembly, Ring (22), and Retainer (19) should only be done if any of them are to be replaced. The Shroud (21) is compressed against the Curved Washer (20) to allow removal of the Ring (22). Once the Ring is removed the other parts may be removed.
- The Teflon Seal (3) and O-ring (4) should only be removed if the Seal (3) is damaged. The O-ring (4) is a fluoro-silicone compound and is not affected by age. To remove it use an "O-ring pick" being careful not to damage the Adapter (18). Once removed, the Seal (3) must be replaced as well as the O-ring (4).

Removed and discard Gasket (23A).

3.5 44771 - 2" Camlock Inlet – Option S (see Fig. 5) with 60427 Type Quick Disconnect, Female Half.

- Do not remove camlock Coupling (32) from unit unless it is to be replaced or there is leakage at the joint between the Coupling (32) and the Housing (31).
- Removed and discard Gasket (23A).
- Remove Lockwire (28) from Screws (27). Take note of the method of lock-wiring for duplication upon reassembly.
- Remove Screws (27) and set aside.
- Using a small screw driver or similar pointed instrument, move the "C" Ring (30) from its locked position groove (one farthest from the inlet thread) to its unlocked position groove (one nearest to the inlet thread). Note that the Sleeve (26) can be moved unrestricted toward the inlet thread, except by the Ring (30). If the Sleeve is moved too far the Balls (29) will fall out of the Housing (31).
- Pre-disassembly of Quick Disconnect (24) Inspection - Prior to disassembling Quick Disconnect (24), perform the following inspection procedure:
 - Slide the Sleeve (26) to the locked position (away from the threaded end of the Housing (31) and lock it in place with one Screw (27).
 - Attempt to insert gauge 220351 into the open end (opposite to the threaded end). If the gauge slides into the part, the Sleeve (26) is worn out and has to be replaced. If the gauge does not enter the part, the unit is acceptable for use and disassembly can continue as below.
 - If the complete Disconnect (24) is to be disassembled, remove the retaining Ring (30), then the Sleeve (26). Remove the 16 Balls (29).

- 3.6 44362 Male Adapter - Option "9"** (see Fig. 5). The Teflon Seal (4) and O-ring (3) should only be removed if the Seal (4) is damaged. The O-ring (3) is a fluoro-silicone compound and is not affected by age. To remove it use an "O-ring pick" being careful not to damage the Adapter (34). Once removed, the Seal (4) must be replaced as well as the O-ring (3). Remove and discard O-ring (35).

Newer nozzles will have an Outer Wear ring (5) installed on the ball groove. Older nozzles will not have this item. If present, inspect the Outer Wear Ring (5); remove if necessary, for wear or damage. If not worn then leave it in place.

- 3.7 43045-1 Adapter - Option "2"** (see Fig. 6).- Remove and discard O-ring (35). Seal (39) should be reusable for several times.
- 3.8 47063 MIL-C-24356 Coupling Inlet - Option W** (see Fig. 7). Newer nozzles will have a Outer Wear ring (5) installed on the ball groove. Older nozzles will not have this item. If present, inspect the Outer Wear Ring (5); remove if necessary, for wear or damage. If not worn then leave it in place.

The Teflon Seal (4) and O-ring (3) should only be removed if the Seal (4) is damaged. The O-ring (3) is a fluoro-silicone compound and is not affected by age. To remove it use an "O-ring pick" being careful not to damage the Adapter (44). Once removed, the Seal (4) must be replaced as well as the O-ring (3). Note the O-ring (MS29513-234) used in the coupling end is not furnished by Carter. It should be replaced at each overhaul.

- 3.9 47566 Swivel Elbow D-1/D-2 Inlet – Option N** (see Fig. 8).

- Screw (46) is a self-locking type screw that utilizes a nylon insert in the threads to affect the resistance required to provide the locking. They are designed to be reused a number of times before losing their locking affectivity. Using a torque wrench, remove Screw (36) and Gasket (47) from lower half of Body (50), measuring the torque during removal. If the torque is less than 9.5 in lbs. (0.11-m kg) discard the screw and replace it with a new one during reassembly. Remove and discard Gasket (47).
- Remove Balls (48), 39 each, from unit by use of the Ball Tool or by hand. If Ball Assy Tool 61607 is available, screw it into the boss from which Screw (46) was removed. Hold the nozzle such that the Tool is below the nozzle and rotate the accessory attached to the nozzle until all Balls (48) have been captured in the Tool. The correct amount of Balls (46) will be captured when the level of Balls (46) reaches the line scribed on the tube of the Tool. If the balls are to be removed by hand (without the tool) hold the bolt hole vertical (pointed down) and allow all ball bearings to fall through the bolt hole. Catch all balls in a container. Some rotation between the two main parts of the unit may be necessary.
- The two halves of the unit may be separated by twisting and pulling apart. If the Clip (56) is to

be removed, a pair of needle nose pliers to grasp the existing part and pull it from the hole in the Swivel Elbow (50).

- Remove and discard O-ring (53).
- Inspect the Inner Wear Ring (52) on the Swivel Elbow Assembly (49); remove if necessary, for wear or damage. If not worn then leave it in place.
- Inspect the Outer Wear Ring (5) on the Swivel Elbow Assembly (49); remove if necessary, for wear or damage. If not worn then leave it in place.
- The Teflon Seal (3) and O-ring (4) on the Swivel Elbow Assembly (49) should only be removed if the Seal (4) is damaged. The O-ring (4) is a flurosilicone compound and is not affected by

age. To remove it use an "O-ring pick" being careful not to damage the Swivel Elbow (50). Once removed, the Seal (3) must be replaced as well as the O-ring (4).

- Inspect the Outer Wear Ring (5) on the Inlet Swivel Assembly (54), remove if necessary, for wear or damage. If not worn then leave it in place. remove if necessary, for wear or damage. If not worn then leave it in place.
- The Teflon Seal (3) and O-ring (4) on the Inlet Swivel Assembly (54) should only be removed if the Seal (4) is damaged. The O-ring (4) is a flurosilicone compound and is not affected by age. To remove it use an "O-ring pick" being careful not to damage the Swivel Elbow (50). Once removed, the Seal (3) must be replaced as well as the O-ring (4).

4.0 INSPECTION & SPECIAL TOOLS

It is recommended that the following parts be replaced at each overhaul:

Part number	Description	Used on, nozzle option
210174-337	Quad-ring	44325, Option CK
201201-231	O-ring	44362, Option 2 & 9
MS27030-6	Gasket	44325, Option CK & 44771, Option S
MS29512-03	Gasket	47566, Option N

Inspect all metal parts for dings, gouges, abrasions, etc. Use 320 grit paper to smooth and remove sharp edges. Replace any part with damage exceeding 15% of local wall thickness. Use alodine 1200 to touch up bared aluminum.

Special inspection tool, 220351, should be used to determine the acceptability of the Sleeve (26) on 44771 Inlet.

5.0 REASSEMBLY

5.1 Reassemble in reverse order of disassembly (Refer to Figures 1 through 7), observing the following:

5.1.1 Make certain all components are clean and free from oil, grease, or any other corrosion resistant compound on all interior or exterior surfaces. Wash all parts with cleaning solvent, Federal Specification P-D-680 or equivalent, and dry thoroughly with a clean, lint-free cloth or compressed air.

WARNING:
Use cleaning solvent in a well-ventilated area. Avoid breathing of fumes and excessive solvent contact with skin. Keep away from open flame.

5.1.2 NOTE: A light coat of petrolatum, Federal Specification VV-P-236 or equivalent commercial quality, can be applied to all O-rings and screws for ease of installation.

5.1.4 On all units but 44771 and 43045-1, install O-ring (4) in groove, as appropriate. Carefully expand Seal (3) over end of adapter and place it into the appropriate groove over the O-ring (4). If there was an Outer Wear Ring (5) present and it was removed be sure to replace it. **Do not use the part without the ring if it was present.**

5.1.4 On 44325, if Wave Washer (17) is being installed it will be necessary to bend it somewhat to properly install it. The shape of the "waves" is not critical and the part will be flattened out somewhat upon reassembly to the Adapter (18).

When installing Shroud (21) be sure that it is oriented such that it will cover up and retain the Ring (22) upon final assembly.

Upon reassembly of the Screws (13) Lockwire (12) should be installed to prevent loosening of the Screws.

5.1.5 On 44771, upon reassembly of the Screws (27) Lockwire (28) should be installed to prevent loosening of the Screws.

5.1.6 On 47566 if the Clip (56) was removed be sure it is installed in the Swivel Elbow (50) properly such that the bent end of the clip (56) is pointing outward.

6.0 TEST

- 6.1 The Unit shall be tested as a part of a completed nozzle or coupler as instructed in SM61429 or SM64349.

7.0 ILLUSTRATED PARTS LIST

Table 1.0 tabulates the parts and sub-assemblies comprising the Various Inlet Assemblies. The item

numbers of the table are keyed to the exploded view of the units diagrammed in Figures 1 thru 7.

TABLE 1.0

Fig.	Item	Part Number	Description	Units/ Assy	Used on option	Spare/10 units/yr
1	1	44326	D-2 Inlet	1	J	-
	2	207874	Inlet	1	J	-
	3	207807	Seal	1	J	5
	4	M25988/1-040	O-ring	1	J	5
	5	220894	Outer Race Ring	1	H,J,N,S,W,9	-
2	6	44327	D-1 Inlet	1	H	-
	7	207873	Inlet	1	H	-
	3	207807	Seal	1	H	5
	4	M25988/1-040	O-ring	1	H	5
	5	220894	Outer Race Ring	1	H,J,N,S,W,9	-
3	8	44325	2" Camlock QD	1	CK	-
	9	44373-100	Screen Assy	1	CK	-
	10	208091	Ring, Retainer	1	CK	-
	11	208092-100	Screen, 100-mesh	1	CK	-
	12	GF20995C32	Lockwire	A/R	CK	A/R
	13	GF24673-9	Screw	2	CK	-
	14	GF960C416	Washer	2	CK	-
	15	207875	Housing	1	CK	-
	16	210174-337	Quad-ring	1	CK	10
	17	207995	Wave Washer	1	CK	-
	18	207809	Adapter, Male	1	CK	-
	19	207810	Retainer	1	CK	1
	20	207811	Wave Washer	1	CK	-
	21	208001	Shroud	1	CK	-
	22	RS-318-S	Ring, Retainer	1	CK	-
	3	207807	Seal	1	CK	5
	4	M25988/1-040	O-ring	1	CK	5
	5	220894	Race Ring	1	CK	5
	23	82415	Camlock Assy	1	CK	-
	23A	MS27030-6	Gasket	1	CK	10
4	24	44771	2" Camlock QD	1	S	-
	25	43108-5	Quick Disconnect, 2" NPT	1	S	-
	26	25081	Sleeve	1	S	-
	27	GF35275-260	Screw	2	S	-
	28	GF20995C32	Lockwire	A/R	S	A/R
	29	GF19060-26	Ball	16	S	-
	30	25083	Lock Ring	1	S	-
	31	28691	Housing 2 NPT	1	S	-

Fig.	Item	Part Number	Description	Units/ Assy	Used on option	Spare/10 units/yr
4	32	82415	Camlock Assy	1	S	-
	23A	MS27030-6	Gasket	1	S	10
5	33	44362	Male Adapter	1	9	-
	3	207807	Seal	1	9	5
	4	M25988/1-040	O-ring	1	9	5
	5	220894	Race Ring	1	9	-
	34	221651	Adapter	1	9	-
	35	201201-231	O-ring	1	9	10
6	36	43045-1	Adapter	1	2	-
	37	203397	Adapter	1	2	-
	35	201201-231	O-ring	1	2	10
	38	Left intentionally blank				
	39	MS27194-40	Seal	1	2	2
	40	GF35308-336	Screw	6	2	-
	41	GF960C516	Washer	12	2	-
	42	GF21083-C5	Nut	6	2	-
7	43	47063	Adapter, MIL-C-24356	1	W	-
	3	207807	Seal	1	W	5
	4	M25988/1-040	O-ring	1	W	5
	5	220894	Outer Race Ring	1	H.J.N,S,W, 9	-
	44	221123	Adapter	1	W	-
8	45	47566	Swivel Elbow Inlet Coupling	1	N	-
	46	220484	Screw	1	N	-
	47	MS29512-03	Gasket	1	N	10
	48	221075	Ball		39	N
	49	47561	Swivel Elbow Assembly	1	N	-
	50	221810	Swivel Elbow	1	N	-
	51	Left intentionally blank				
	5	220894	Outer Race Ring	1	N	-
	52	220893	Inner Race Ring	1	N	-
	3	207807	Seal	1	N	10
	4	M25988/1-040	O-ring	1	N	10
	53	M25988/1-235	O-ring	1	N	10
	56	209853	Clip		1	N
	54	47558	Inlet Swivel Assembly	1	N	-
	55	221809	Inlet Swivel	1	N	-
	5	220894	Outer Race Ring	1	N	-
	3	207807	Seal	1	N	10
	4	M25988/1-040	O-ring	1	N	10

- Notes:
1. The recommended spare parts shown above are the number required to support 10 Units for one year or each overhaul whichever is sooner. These quantities do not include replacement spares for intermediate replacement of parts required by abuse or misuse of the equipment. The recommended quantities are based on the ratio of spare parts sold for each unit during a one year period of time. The actual quantity required will vary from location to location.
 2. All part numbers beginning with "GF" are interchangeable with those beginning with either "AN" or "MS". If the "GF" is followed by three numbers it is interchangeable with and "AN" part, otherwise it is interchangeable with an "MS" part of the same number.

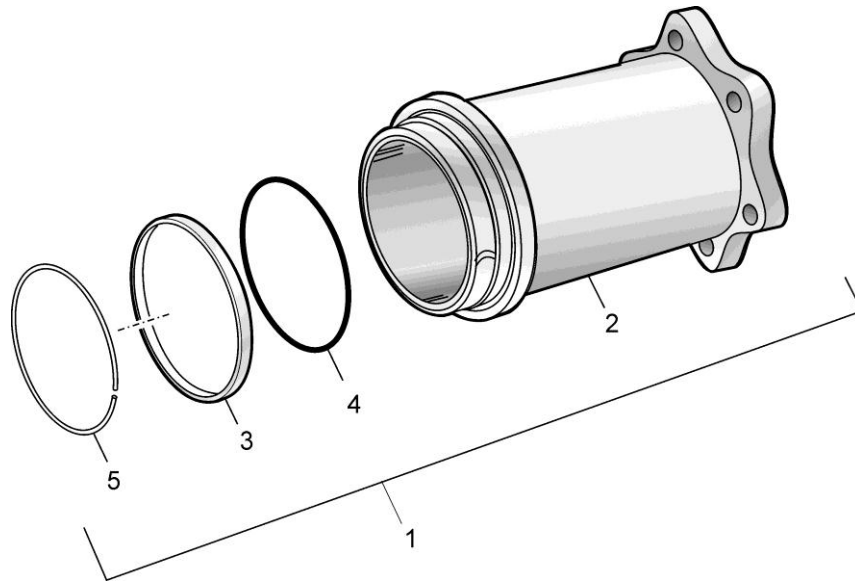

FIGURE 1
44326 D-2 INLET – OPTION J

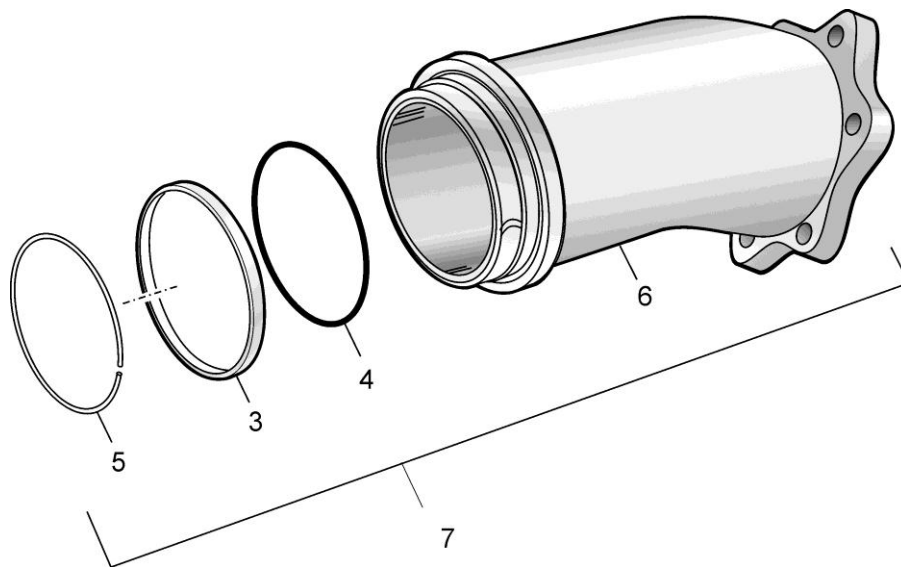

FIGURE 2
44327 D-1 INLET – OPTION H

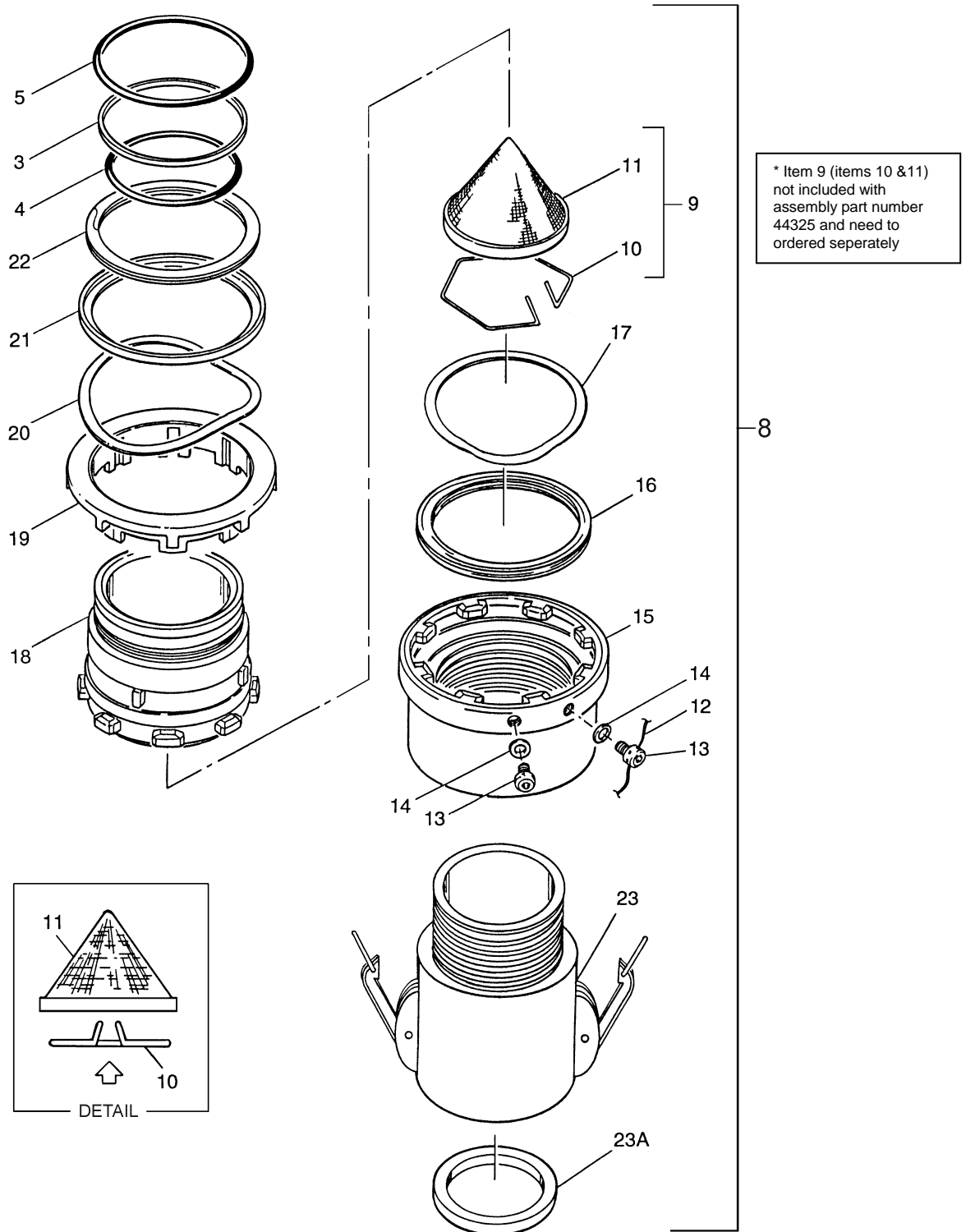

FIGURE 3
44325 INLET – OPTION K

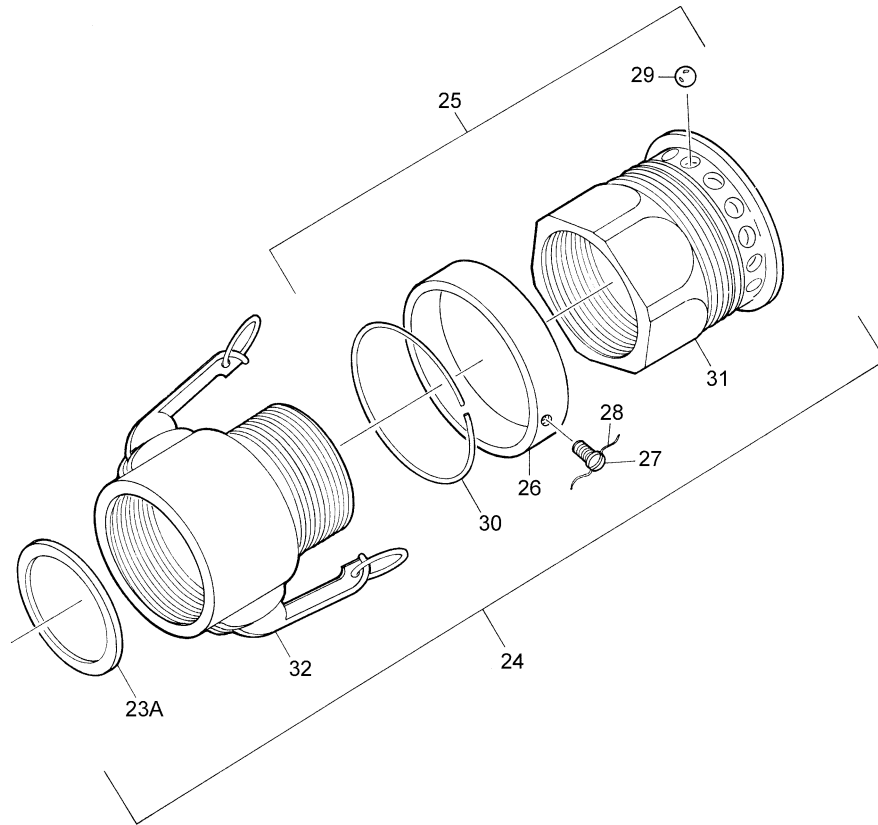

FIGURE 4
44771 Inlet – Option S

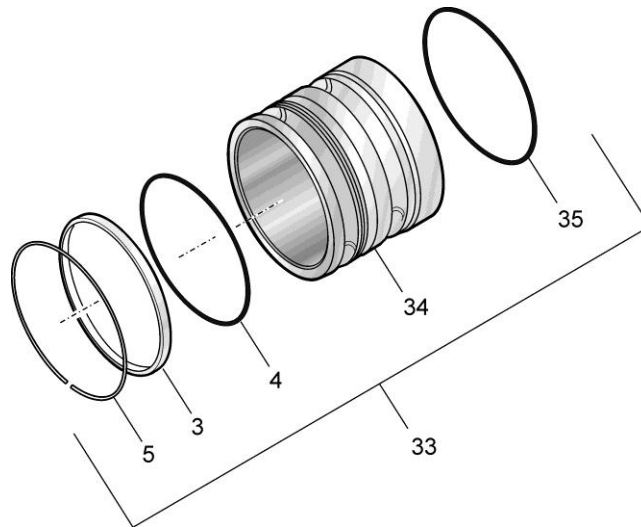

FIGURE 5
44362 ADAPTER – OPTION 9

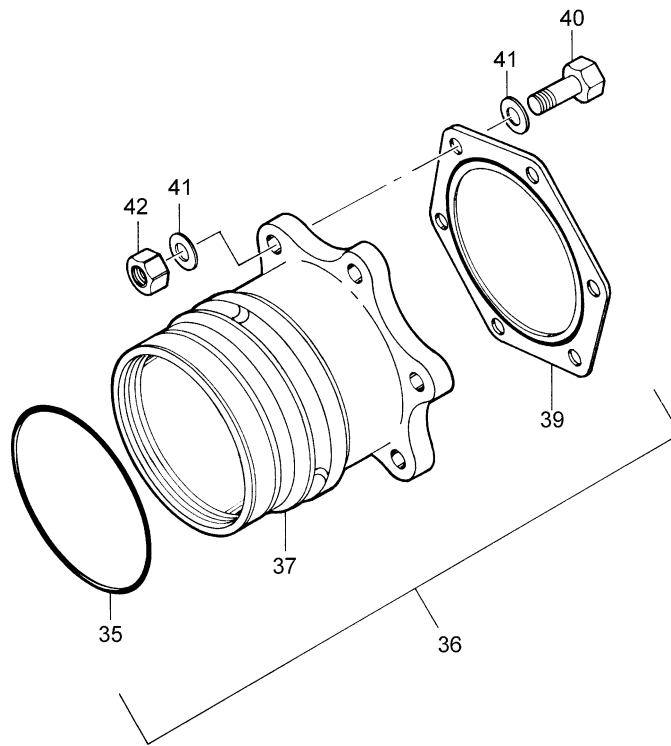

FIGURE 6
43045-1 ADAPTER - OPTION 2

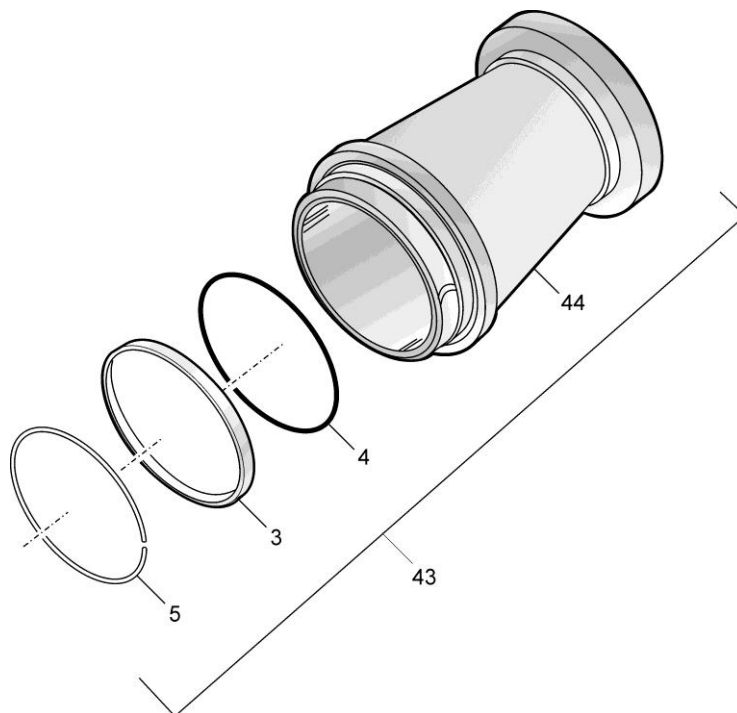

FIGURE 7
47063 INLET - OPTION W

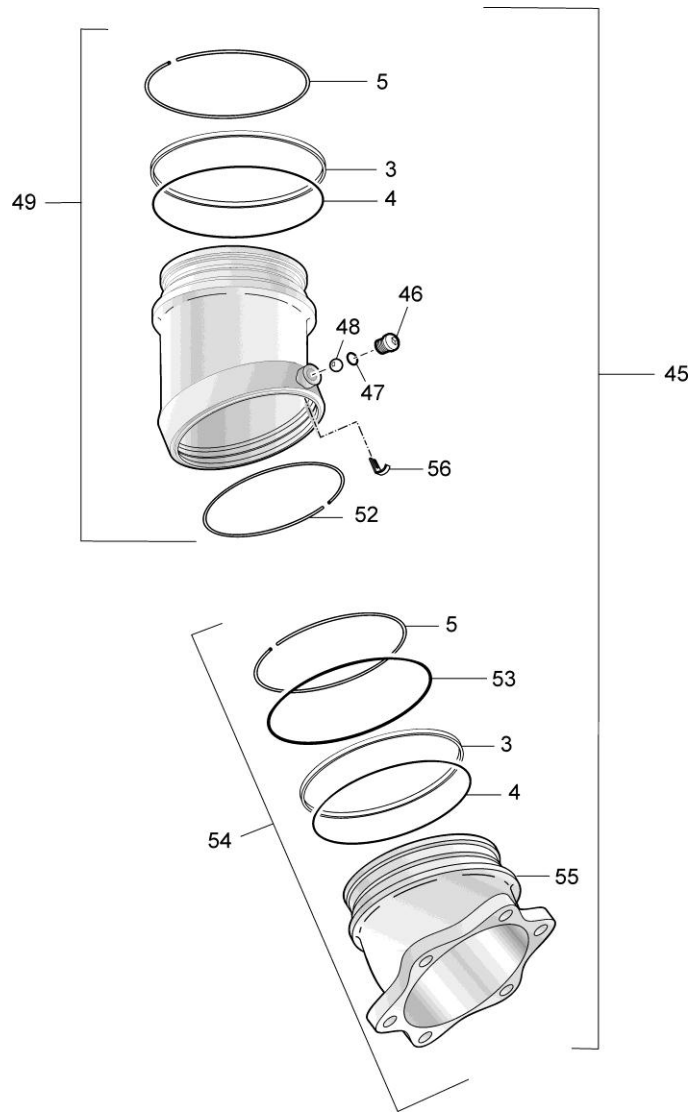

FIGURE 8
47566 SWIVEL ELBOW INLET COUPLING - OPTION N

Eaton
Aerospace Group
Fluid & Electrical Distribution Division
9650 Jeronimo Road
Irvine, CA 92618
Tel (949) 452-9500
Fax (949) 452-9992