



Powering Business Worldwide

Aerospace Group
Conveyance Systems Division
Carter® Ground Fueling

SM60700-1

April 2011

Applicable addition manuals:
None

Maintenance & Repair Manual

Hydrant Coupler With Pressure Control

To Mate Hydrants in Accordance with API Bulletin 1584

Model 60700-1

TABLE OF CONTENTS

	<u>Page</u>
1.0 Introduction	3
2.0 Equipment Description	3
3.0 Table Of Options	4
4.0 Operations	4
5.0 Safety Instructions - Periodic Inspections	8
6.0 Trouble Shooting And Minor Repair	11
7.0 Installation	18
8.0 Special Tools	19
9.0 Disassembly	20
10.0 Inspection And Repair	23
11.0 Reassembly	26
12.0 Test	31
13.0 Storage	34
14.0 Illustrated Parts Catalog	42
15.0 Obsolete Parts Information	40
Figure 1 - Overall Coupler View	43
Figure 2 - Lower Half Coupler View	44
Figure 3 - Pressure Control Elbow Assy	45
Figure 4A - Female Half QD (O-ring Type)	46
Figure 4B - Female Half QD (Teflon Seal)	47
Figure 5 - Collar Stop Lock Assy	47
Figure 6 - Carriage Assy	48
Figure 7 - Collar Stop Assembly Method	49
Figure 8 - Carriage Assy Installation	50
Figure 9 - Inner Piston Seal Installation	51
Figure 10 - Air Orifice Adjustment	51
Figure 11 - Coupler Upper Half Flange	52

Maintenance, Overhaul & Test Instructions

Eaton's Carter® Brand Model 60700-1 Hydrant Coupler

1.0 Introduction

This manual furnishes instructions for the installation, operation, periodic inspection, trouble shooting and minor repair, as well as complete overhaul of the Eaton Carter brand Model 60700-1 fuel pressure control couplers, designed to mate adapters and hydrant valves built in accordance with API Bulletin 1584.

Maintenance and overhaul of repairable subassemblies, including all the various options are also included.

The last section of this manual contains assembly drawings for identification of replaceable parts and other significant maintenance items referred to in the instructions. References in the text to the assembly drawings for part identification are by item number in the list of material on the drawing.

2.0 Equipment Description

The standard Model 60700-1 fuel pressure control coupler consists of three basic modules; a standard Model 61525 dry break coupler lower half, a fuel pressure control elbow assembly, and various female disconnects, each with a different thread type and size, as explained below. Two different types of outlet disconnects are available, the long-time standard O-ring type used in options K, L, M, N and P; and the Teflon seal type in Options R and S. The latter versions (options R & S) allow the conversions of an existing Model 60600 coupler to a Model 60700-1 coupler using the existing female half of the QD Model 61525 lower coupler half. Another option (A) is available with seals more compatible for temperature operation lower than -40°F (-40°C). Other options are available as explained further in the following table.

The coupler is designed to mate with standard 4-inch adapters and hydrant valves that conform to API Bulletin 1584.

The outlet of the unit may be equipped with one of five female half quick disconnects. The sleeve of the female half quick disconnect provides a carrying handle. The five types of disconnects are identical except for the female pipe thread size and type incorporated in the housing that mates with the hose fitting. The table in paragraph 3.0 that follows, tabulates the various options available with the basic unit.

The Model 61525 coupler provides a quick means to connect to a hydrant or adapter with dry break capability. The coupler can not be accidentally opened unless it is connected to a valve; it can not be removed from that valve unless it is in the closed position.

The unit incorporates a pressure operated relief valve that is automatically opened by the coupler when the coupler poppet is closed, to provide a vent to the downstream side of the main piston seat, relieving a hydraulic lock that would otherwise prevent coupler poppet closing. The spring loaded relief valve also relieves

automatically whenever the differential pressure across the closed pressure control piston seat exceeds approximately 220 psi in the inlet to outlet direction.

The 42208-1, 42208-3 and 42208-4 pressure control elbow assemblies are direct operated, normally closed, fuel pressure control and shutoff valves. They differ only in the outlet configuration (options R & S) to allow them to be mated with their appropriate quick disconnects and for lower temperature operation (option A). Application of 25–33 psig air pressure (bias) greater than the maximum desired fuel pressure through the air pressure connector overrides the piston spring and, opposed by remote sensed fuel pressure, holds the piston in the positions required to maintain the desired regulated pressure at the remote sensed point throughout the ranges of all normal inlet pressure and fuel flow rates. The actual bias will vary approximately within the above range from low to high flow rates of the system. The hydrant system inlet pressure will have some affect on the actual bias as well. The range of bias will be reduced with an increase in inlet pressure. Release of the air pressure, normally through a three-way deadman type valve, results in the spring force plus the fuel sense pressure causing the main piston to close. The main piston also closes whenever the downstream flow passages are blocked, causing the fuel sense pressure transmitted back from the remote sensed location to rise above the preset limits, (1.5 psi).

An adjustable orifice screw in the deadman air passage restricts air flow in and out of the air piston chamber which in turn primarily limits the units closing rates. (Older units incorporated a fixed diameter orifice and no adjustment was possible. It has been the practice of some refueling vehicle manufacturers to modify this factory orifice, hence Eaton cannot guarantee that the unit, if modified, will meet the factory specifications.) The adjustable needle valve type orifice was incorporated in all units with serial

numbers 1919 thru 1923 and 1930 and subsequent. Later units, serial number 2476 and subsequent, will have a spring loaded screw with an orifice slot. This unit is simpler to adjust and is preferable over the needle valve type.

The unit opening rate is primarily limited by a restrictor check valve, located in the fuel sense port, that restricts fuel flow out of the inner piston chamber but that allows full flow in the piston closed direction. Again it has been the practice of some vehicle manufacturers to modify the fuel orifice. On serial numbers 1930 and subsequent,

the factory units utilized a slightly smaller orifice. The area between the inner piston fuel and air dynamic seals is vented to exterior ambient through generous passages so that fuel cannot leak into the air system and air cannot leak into the fuel. The ambient vent is protected by a screen to prevent aspiration of external contaminants into the unit.

On units with serial numbers of 2400 or greater, a cartridge assembly was used in the main elbow housing to facilitate the installation of the smaller piston seals.

3.0 Table Of Options

The basic Model 60700-1 is available with a variety of options to customize it to meet specific requirements as listed in Table 1 below. The various options, when compatible, may be combined and listed following the basic part number 60700-1 to achieve a complete unit. For

example: 60700-1BCGK is a basic unit with a folding handle (1-B), product selection (1-C), external dust cap (standard), collar stop assy (1-G) and a female half quick disconnect with carrying handle and 3" NPT outlet (1-K).

Table 1

Option Letter	Part Number	Description
A	42208-4 & 47113	Replaces seals with lower temperature capability.
B	41731	Replaces standard rigid handle with folding handle.
C	41802	Adds product selection.
D	GF20995C32	Adds lockwire to bolts attaching upper and lower halves.
G	44140	Adds collar stop assembly.
K	41730-3 & 4208-1	Uses elbow to mate O-ring type QD & adds 3" NPT female half QD and carrying handle.
L	41730-4 & 44208-1	Uses elbow to mate O-ring type QD & adds 3" BSPP female half QD and carrying handle.
M	41730-1 & 44208-1	Uses elbow to mate O-ring type Qd & adds 4" NPT female half QD and carrying handle.
N	41730-2 & 44208-1	Uses elbow to mate O-ring type QD & adds 4" BSPP female half quick disconnect and carrying handle.
P	60740 & 44208-1	Uses elbow to mate O-ring type QD & adds 4" ASSPT female half QD and carrying handle.
R	47087-3 & 42208-3	Uses elbow to mate Teflon seal type QD & adds 3" NPT female half QD and carrying handle.
S	47087-1 & 42208-3	Uses elbow to mate teflon seal type QD & adds 4" NPT female half QD and carrying handle.
T	42208-3	Uses elbow to mate Teflon seal type QD, 47087-1 or -3.
W	60532A	Adds carriage assembly.
X	47073	Adds forward handle assembly (option B must be used with option X).

4.0 Operation

Operation consists of connecting the coupler to the hydrant pit valve adapter, applying air pressure to the unit by actuation of the system deadman control to open the pressure control valve, flowing fuel through the open coupler and valve for the required period, closing the pressure control valve by releasing the deadman control, and disconnecting the coupler from the hydrant adapter. Operation may also include

reverse flow through the unit for off-loading or defueling purposes.

4.1 Coupler Connection

Connection of the coupler to the four inch API-type adapter is simply accomplished. Proceed as follows:

A. Remove the dust cap assembly and place the face of the coupler assembly over the

pit valve adapter. Use one hand to overcome hose weight bending forces so the coupler face is centered and square to the adapter face. Normally the weight of the coupler, when properly aligned, will cause the spring loaded detent pin to be depressed by the adapter flange, permitting the collar to drop, locking the 16 lugs to the adapter. **If the unit incorporates Option C, Product Selection, it may be necessary to rotate the collar before it can drop. This can be done easily by rotating only the collar. It is not necessary to rotate the coupler body and the servicer pickup hose.**

B. With the collar dropped or extended, the poppets may be opened by simply rotating the coupler poppet operating handle in the open direction as permanently marked on the handle.

Note: It should be understood that the poppet operating linkage is over center with the poppet operating handle in either the fully closed or fully open position. This feature is required to prevent internal pressure from opening the poppet when the mechanism is in the closed position; and, for that matter, to prevent an external force from closing the mechanism when it is fully open. Consequently, the initial poppet operating handle open movement causes the poppet to retract slightly into the coupling before moving in the poppet open direction. Further, the poppet operating handle cannot be operated in the open direction if the collar is not extended, or dropped, because of a physical interference between the handle and the collar. At the same time, the collar cannot be extended, or dropped unless the spring loaded detent pin is depressed, normally by the face of the pit valve adapter. Once extended, the collar cannot be retracted if the poppet handle is in other than the fully closed position and if the optional Collar Stop Assy (1-G) is not depressed. Together, these features provide safety interlocks that prevent accidental opening of the coupler poppet with the unit disconnected, or disconnection with the poppet open and a potentially hazardous or undesirable product spill.

C. If the adapter is pressurized by hydrant pressure at the time of poppet opening, resistance will be felt when the coupler poppet contacts the adapter poppet. The resistance will be proportional to the hydrant pressure. The force resisting opening of an Eaton Carter brand hydrant valve is composed of two factors, poppet spring force plus any force created by fuel pressure in the hydrant. The normal spring force is approximately 20 pounds and the pressure force is equal to over 125 pounds for each 10 psi present. In addition to the forces attributed to the hydrant, there are forces presented by the coupler itself. The initial movement of the operating handle to get it **over center** is resisted by a stack of wave washer springs on the nose seal plus seal friction. Under even severe weather conditions, the coupler can

be opened by the application of less than 30 pounds force applied to the handle. Since the adapter poppet is equipped with a pressure equalizing valve, maintain a steady, moderate force on the handle in the open direction, sufficient to hold open the adapter pressure equalizing valve until the pressure has equalized across the poppets. Then the handle can be easily moved to the fully open position, permitting full communication between the hydrant adapter and the fuel pressure control valve.

It should be noted that the early release of the API Bulletin 1584 did not cover the need for a pressure equalizing valve. This resulted in the hydrant valve manufacturers having different dimensions for the location of the operating tip of the valve. There is some incompatibility between the various older hydrants and couplers if they are intermixed. The result can be either one of considerable leakage during hookup or non-function of the equalizing valve making it very difficult to achieve connection.

Note: The time required for pressure equalizing to occur is contingent on the unfilled downstream volume, the capacity of the adapter pressure equalizing valve, and the hydrant pressure.

4.2 Fuel Pressure Control Valve Operation

4.2.1 Discussion

Figure A is a schematic diagram of the Fuel Pressure Control Elbow Assembly Module (unit) on which the major functional elements are illustrated and labeled. While Figure A is schematic, the general shapes of the parts have been retained as much as possible to permit a better understanding of the actual hardware.

The inner and outer piston assembly has been split on Figure A so that the lower half illustrates the position of the pistons when the unit is closed, either because deadman air pressure is not applied or because the fuel sense pressure and the piston spring have overpowered the air pressure, and other opening forces that might be present. The upper half of the piston assembly on Figure A illustrates the position of the pistons when the unit is partly open and regulating fuel pressure.

Referring to Figure A while reading this section of the manual should assist in achieving a through understanding of the unit operation.

With the coupler engaged and the poppets open, hydrant pressure is available at the unit's outer piston seat. The unit's piston is held normally closed by piston spring force until air pressure is applied, usually through a 3-way normally closed valve known as a deadman valve (since release of the valve's handle blocks air pressure supply to, and vents air from, the unit).

In common with pilot operated pressure control valves, this direct operated unit incorporates an

air pressure over regulated fuel pressure bias. In this direct operated unit, however, the bias is provided by the main piston spring, which is not adjustable.

The piston spring design is such that the spring bias force equals approximately 25 psig air over fuel pressure when the unit piston is near the seat and as much as 33 psig air over fuel pressure when the piston is fully open. These numbers cannot be absolute for all possible installations since there is a small area imbalance in the piston open direction caused by slight differences in sealing diameters of the outer piston's dynamic seal and its seat. With 140 psig hydrant pressure applied, the imbalance translates into 5 psig less air pressure required than pure force calculations imply.

So it is necessary to adjust the deadman air pressure applied to the valve to achieve the desired delivery pressure.

At any rate, if the regulated pressure at the remote sensed delivery point is considered to be too high, or too low, it is a simple matter to either increase, or decrease, the air pressure to achieve the desired delivery pressure. Of course, if the delivery pressure is low because inlet pressure is insufficient to overcome system resistance at high flow rates, then increasing the air pressure will not increase the delivery pressure (since the unit is already fully open under those conditions) and will result in higher downstream pressure during normal shutoff. It should also be understood that using very high air pressure to compensate for system pressure losses will result in high shutoff and surge arrest pressures.

4.2.2 Refueling

Considering the previous discussion concerning bias, assuming that the unit has been filled and properly bled of air (see paragraph 7.5) and that the deadman air pressure is preset at the desired value, then the only action required to operate the automatic fuel pressure control valve (unit) is to squeeze the deadman valve to apply the air pressure and open the piston.

The main piston opening rate is limited by a restrictor check valve in the fuel sense passages that restricts displacement of fuel from the fuel control chamber as the chamber's volume decreases when the piston opens.

The piston continues to open until the pressure at the remote sensing point, transmitted back

through the fuel sense line, reaches the range that is equal to the applied air pressure less the bias force of the main piston spring. At this flow rate, the main piston modulates to maintain an equilibrium of forces across the inner piston and provides automatic pressure control by varying the effective flow area at the outer piston.

As the receiver aircraft tanks progressively fill and shut off, the flow reductions in each instance cause the pressure to increase at the remote sensing point. These pressure increases are transmitted back through the fuel sense hose. The previously mentioned restrictor check valve is lightly spring loaded in that it begins to open when the fuel sense line pressure is approximately 1.5 psig greater than the inner fuel piston chamber pressure, creating a variable orifice in parallel with the very small orifice that restricts control fuel flow in the reverse direction. The increase in fuel chamber pressure causes the piston to move in the closed direction, reducing the outlet pressure, until the fuel pressure transmitted back through the fuel sense line has established a new force equilibrium condition about which the piston modulates until the next receiver aircraft tank fills and shuts off.

When the last receiver aircraft tank has shut off, the conditions described above cause the unit piston to fully close and block hydrant pressure, preventing high pressures from reaching the aircraft manifolds as well as the servicer delivery equipment.

The rapid response inherent in a direct acting regulator combined with the essentially free flow of control fuel into the remote fuel sense chamber makes the unit an effective automatic surge control device when fueling aircraft with fast closing (1-2 second) shutoff valves.

Release of the deadman valve at any time will cause the unit to close. The piston closing rate in this mode of operation is a function of the air passage orifice, the air hose volume, and any restrictions in the deadman valve. (The fuel restrictor check valve does not significantly affect closing rate since it easily opens to allow fuel to enter the fuel sense chamber in this closing mode.) The bias force supplied by the piston spring causes the unit piston to be fully closed by the time the air pressure on the air side of the unit inner piston has decayed to about 20 psig.

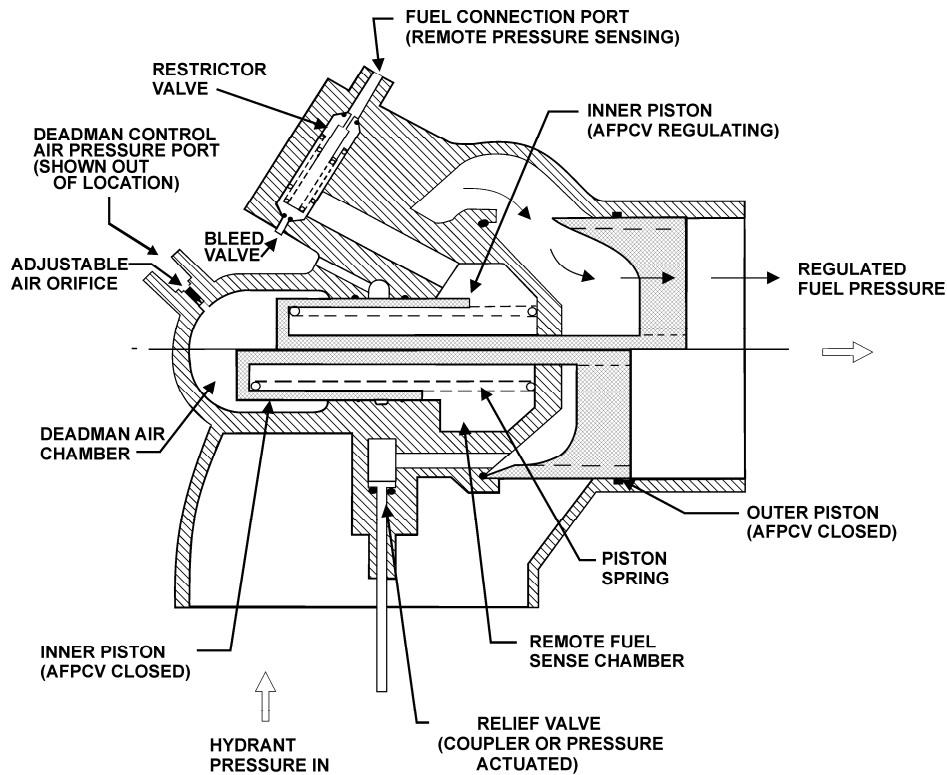

Figure A
Schematic Diagram Pressure Control Elbow Assy

4.2.3 Defueling

Should it become necessary or desirable to defuel through the automatic fuel pressure control coupler, it is necessary to either apply an air pressure that is at least 30-35 psig higher than the defuel pressure, or to provide a means of blocking the fuel sense pressure and venting the unit fuel sense chamber to a vented container.

Obviously, if adequate air pressure is available, the simplest method of defueling consists of merely applying enough air pressure to overcome the closing forces created by the fuel sense (defuel) pressure and the piston spring.

Direct acting pressure regulators of this type may become unstable at some point in the piston stroke during reverse fuel flow. So it is mandatory that the unit is fully opened by enough air pressure (30-35 psig greater than the maximum defuel pressure) to overcome the defuel pressure and piston spring forces before start of reverse flow.

If it is necessary to defuel into a relatively high pressure hydrant system, it is reasonable to assume that sufficient air pressure may not be available. The balance of this discussion is concerned with methods of venting the fuel sense chamber to permit opening of the unit with air pressure no higher than that required for normal operation.

4.2.3.1 Frequent Defueling Operations

If the fuel control coupler is installed on a servicer or dispenser that is frequently used for defuel operations, then it is perhaps desirable that the dispenser design include a spring-loaded, two position, three-way selector valve in the fuel sense line between the unit and the remote sensed location. Such a valve should be installed so that, with the spring holding the valve in the "normal" position, two of the valve's ports provide through and unrestricted transmission of the fuel sense pressure while the third port is blocked.

Manually overriding the spring and holding the valve in the "defuel" position should, in turn, block the remote sensing point port of the valve and cause the unit fuel sense connection to communicate with the selector valve's third port. This port might best be connected through a simple check valve and suitable tubing or hose to a small, vented container. The selector valve's design should be such that release of the control handle results in spring return of the valve to the "normal" position to provide fail safe deadman-type operation.

A simple check valve should be provided between the selector valve's third port and the vented container so that flow is free out of the valve, but air return is blocked. (The check valve flow arrow should point away from the selector valve.)

The vented container can be quite small, since the fuel displaced by the unit piston when it

opens is on the order of one cupful. Of course, if the servicer is already equipped with a "dump tank", then an additional container is not required.

With a servicer so equipped, defueling procedures are simplified to applying defuel pressure equal to hydrant pressure, holding the fuel sense selector in the "defuel" position, applying deadman air pressure, and increasing the defuel pressure to the valve necessary to off load the fuel at the desired rate.

At the conclusion of defueling operations, the defuel pressure should be decreased to equal hydrant pressure, then the deadman air and fuel sense selector valve may be released to close the unit.

4.2.3.2 Infrequent Defueling Operations

If the unit is installed on a servicer that is used in defueling operations very infrequently, then inclusion of the design provisions discussed in 4.2.3.1 is perhaps not justifiable nor warranted.

In this case, it will be necessary to disconnect the fuel sense hose at the remote sense point, and plug or cap the port at the remote sense location. The disconnected hose must be left open to atmosphere while the unit is opened and closed during the off loading operation.

It is also necessary to refill and bleed air from the fuel sense hose and inner piston fuel chamber when the fuel sense hose is reconnected following the defuel on/off loading operations.

4.3 Coupler Disconnection

Coupler disconnection is essentially the reverse of connection.

Proceed as follows:

A. First, the poppets must be closed by rotating the poppet handle in the direction marked closed. During the final portion of handle closing travel, a resistance will be felt as the coupler poppet enters the seal and must displace the liquid trapped within the coupler and unit.

B. Maintain a moderate steady force in the closed direction to permit the coupler poppet shaft to open the relief valve in the unit and vent some of the trapped liquid downstream of the unit outer piston seat, permitting the poppets to close.

C. With the poppets closed, the seal between the coupler and the adapter is broken, and a poppet leak check may be accomplished, if so desired.

D. Separation is achieved by using one hand to grasp the hose and hold the coupler square to the adapter, relieving hose weight tension on the lugs locking the coupler to the adapter. Depress the optional collar stop assembly, if present, and lift the collar with the other hand. Then lift the coupler off the adapter. The spring loaded detent pin will extend, locking the collar in the retracted position. With the optional collar lock retracted, a physical interference between the collar and the handle prevents accidental opening of the coupler poppet.

E. Following reinstallation of the optional dust cap, the operational cycle is complete and the unit may be returned with the pickup hose to its normal storage location.

5.0 Safety Information - Periodic Inspections

The equipment described herein is designed primarily for safe, convenient, and reliable operation under normal operating conditions. However, the more exposed parts are subject to damage, and to wear with time that can result in unreliable or unsafe operation if not detected or corrected. Consequently, it is considered mandatory that a brief safety inspection is accomplished periodically. The frequency of this inspection can vary depending upon the utilization, however, under no circumstances should the frequency be less than once a month. A more thorough periodic inspection should be accomplished at least once a year. Both inspections are discussed in the following paragraphs.

5.1 Interlock

The coupler incorporates an interlock feature that prevents it from being opened unless it is installed onto a hydrant or adapter. The unit may not be removed from the hydrant unless the operating handle has been moved to the closed

position. An additional safety system has been made available, as Option G, to prevent the unit from being **blown off** the hydrant in the case where the hydrant valve adapter poppet fails to close. During the connection cycle, the interlock is automatically disengaged by the proper alignment of the coupler with the hydrant. During the disconnection cycle, it is necessary to manually depress the collar stop assembly (if Option G is selected) to allow the collar to be moved away from the hydrant valve and complete the cycle. Should a major leakage occur after the operating handle has been closed and before unlocking the collar stop, this indicates a failure of the hydrant valve poppet. One should first reopen the coupler poppet and make sure that the hydrant valve pilot has been closed and then close the servicing valve on the hydrant valve before attempting to remove the coupler. If the leakage still is apparent, attempt to re-open the coupler to stop the leakage and then shut down the operation of the system prior

to completely disconnecting the coupler to prevent a possible catastrophic spill.

5.2 Quick Disconnect Retention Method

The female half of the quick disconnect assembly is connected to the male half by means of 24 balls that mate with a groove in the male half and are retained there by a sleeve around the outer diameter of the female half. The sleeve maintains inward pressure on the balls to keep them in the groove of the male half. The sleeve itself is maintained in place by a partially circular wire retaining ring. This ring engages coincidental grooves in the quick disconnect housing and the sleeve. The spreading of the retaining ring allows disengagement of the retaining ring from the sleeve groove and, therefore, movement of the sleeve away from the balls. A retainer plate is used to cover the retaining ring to prevent all but intentional spreading. The coupler should never be operated without the installation of this plate. A secondary locking ring is also provided to prevent the sleeve from moving away from the coupler unless it is intentional.

5.3 Carriage Assembly - Option W.

When utilized, the Carriage Assy incorporates a torsion spring which can produce potential injury if the unit is not handled properly. Extending and retracting the castors of the unit should be done with care to prevent possible injury.

5.4 Monthly Periodic Inspections

5.4.1 Safety Inspections

Accomplish the following at once each month: (An experienced operator should be able to accomplish these inspections in 30 to 45 seconds.)

A. While removing the Dust Cap (1-2), inspect the 16 Locking Lugs (2-33) to determine if any are missing, broken, bent, abnormally worn, etc. Verify that the Detent Pin (2-26) is extended and prevents collar extension. While holding the Collar (2-27) retracted, depress the Detent Pin (2-26) and release it to verify that it returns to the extended position. Examine the Collar (2-27) for excessive wear, cracks, or other damage. Verify that the Collar Stop Assembly (1-G) is in place and not bent, if Option G is chosen.

Reason: Missing, damaged, cracked, and abnormally worn or broken lugs can result in fuel pressure ejecting the coupler off the adapter with the poppet open. A stuck or malfunctioning detent pin can permit collar extension and accidental opening of the coupler poppet with the coupler disengaged from the adapter. The collar stop option, if present, prevents gross adapter poppet leakage from raising the collar and blowing the coupler off the adapter.

B. Visually inspect the closed Poppet (2-15, 2-15A or 2-15E) for signs of abnormal

positioning. Visually inspect the molded rubber seal for cracks and tears.

Reason: Abnormal poppet retraction or extension indicates a compression or tension failure of portions of the internal linkage that could either result in a mid-position jam or complete separation of the linkage and accidental poppet opening. Damage to the molded seal can result in coupler connected external leakage or coupler disconnected poppet leakage.

C. If the unit incorporates Product Selection (Option C), verify that it is properly installed and that the bolt heads do not extend above the adjacent collar surface.

Reason: Improper product selection installation will, at the very least, result in an unnecessary connection delay, and at the worst, permit connection to the wrong product.

D. Inspect the poppet operating handle for bent, worn, broken, or missing pieces on the round cam-like surface. Inspect the adjacent surface of the collar.

Reason: The round portion of the handle locks the collar in the engaged, extended position. Broken, bent, or missing portions of this handle, or of the collar may permit accidental collar retraction with the poppets open that could result in the coupler being ejected from the adapter.

E. Visually inspect the socket head Screws (2-2) or (8-19) securing the coupler housing to the elbow for security of installation and damage. If the Carriage Assembly (1-W) is present, Bolts (8-19) holding the Flange (6-9) to the unit must have hex heads. Check torque of these Bolts (8-19) to assure that they are tightened to 90 ± 10 in.-lbs. (104 ± 12 kg-cm). If the Bolts (8-19) are found to be loose, damage to the Elbow (1-1A, 1B or 1C) threaded holes may have occurred and further inspection in accordance with paragraph 5.5.O should be carried out.

Reason: Self-explanatory.

F. Visually inspect the female half quick disconnect to verify that the ball retaining sleeve is fully engaged, and that the ring retainer is secured by two lockwired screws so that the two ends of the retainer ring extend through the remaining two holes in the ring retainer. Verify that the lock ring is engaged in the safety groove immediately adjacent to the ball retaining sleeve.

Reason: See WARNING in paragraph 7.1.

G. Visually inspect the air pressure and fuel sense line connections to the unit's connectors for security of installation and damage. Inspect the unit's body for impact damage or depressions that might cause the main piston to hang open.

Reason: Pressure tight air and fuel connections are required for proper function. Unit body depressions or dents may cause the

main piston to hang open and prevent a deadman release shutdown.

H. If the Carriage Assembly (1-W) is used, check to see that the Bolts (8-19) securing it to the unit have hex heads. Check to assure that the mounting Flange (6-9) of the Carriage Assembly (1-W) is not mounted flush to the flange on the coupler lower half. If single piece spacers or a stack of Washers (8-18), as shown in Figure 7, should be present. If neither is present, or the Bolts (8-19) do not have hex heads, take the unit out of service and repair using kit number 80898. The length of the Bolts (8-19) should be checked in accordance with paragraph 10.6.

5.5 Extended Periodic Inspections - (Annual Inspection)

In addition to the safety inspection advocated above, a more extended inspection should be accomplished. It will be necessary to provide a container to capture entrapped fuel during the following inspection. The parenthetical numbers are the item numbers in the list of materials in the referenced tables.

A. Refer to paragraph 7.1 for method of separating female half quick disconnect from the automatic fuel pressure control valve. Capture spilled fuel in a suitable container.

B. Inspect female half quick disconnect. Inspect Balls (4-8) for chips, flat spots, or excessive wear. Inspect ball retaining Sleeve (4-6) for cracks and wear from the Balls (4-8). Inspect Housing (4-5) for cracks or thread damage.

C. Inspect housing outlet O-ring (3-21) for damage. If damaged, replace with new part. Inspect ball race Rings (3-22) for brinelling (indenting of the material by the Balls (4-8)) and other indications of damage. Replace brinelled or damaged ball race Rings (3-22). Remove outer ball race Ring (3-22) and measure the smallest wire diameter. Replace the ball race ring if the smallest wire diameter is 0.123 inch (3.12 mm) or less. Reinstall an acceptable ball race Ring (3-22).

D. Conduct the Coupler Lower Half inspection detailed in paragraph 9.4. If the specified Wear Gauge, 61362, is not available then continue with the inspections detailed in paragraphs E and F below as an alternative. The use of the Wear Gauge is preferred and will give more positive results.

E. Grasp opposite sides of the Collar (2-27) with the fingers while depressing the spring loaded Detent Pin (2-26) with one thumb. The Collar (2-27) will move to the engaged position, away from the Poppet Operating Handle (2-1 or 1-B). Verify that the 16 Lugs (2-33) cannot be depressed back into the collar with the Collar (2-27) extended.

F. Inspect 16 coupling Lugs (2-33) very closely for wear, cracks or damage. If any Lugs (2-33) are cracked, damaged, missing, or worn locally beyond 0.030 inch (0.76 mm), the unit is unsafe and should be withdrawn from service and completely overhauled. This inspection may be made by comparison with a new Lug (2-33).

Press the tip of one Lug (2-33) inward until stopped by the Collar (2-27). While holding the Lug (2-33) inward, rotate the Collar (2-27) through 360° to determine whether any grooves have been pressed into the Collar (2-27) by the Lugs (2-33) during previous misuse. If such grooves are evident, they will alternately cause the Lug (2-33) to move out and in when it is pressed against the Collar (2-27). If grooves are felt, the coupling is unsafe and should be removed from service and completely overhauled.

Alternately press each Lug (2-33) against the Collar (2-27) to determine which lug protrudes the least distance through the body slot. Then, while holding the Lug (2-33) against the Collar (2-27), use a scale to measure the inward distance the lug tip protrudes from the adjacent body inside diameter. If the measured distance is less than 0.15 inch (3.8 mm) the coupling is unsafe and should be removed from service and completely overhauled.

G. Carefully operate the Poppet Operating Handle (2-1 or 1-B) to the open position while capturing trapped fuel in a suitable container. Operation should be smooth and even.

Note: The molded rubber Nose Seal (2-17) which is normally contained either by the Poppet (2-15) or the pit adapter face, may extend with the Poppet (2-15) contingent on the relative friction between the Poppet (2-15) and the Nose Seal (2-17) and that between the same Nose Seal (2-17) and the O-ring (2-18) and Housing (2-5). (Note: The original design of the unit utilized an O-ring [2-18] and was changed to a quad-ring. The change was motivated by reports of spiral failure of the O-ring by some operators. Unfortunately, the quad-ring, although it stopped the spiral failures, exhibited other problems, namely causing the nose seal to hang up. These problems were caused by the inability of our supplier to consistently furnish the proper compound. The O-ring tended to give better service hence the change back to it. Continued research for a product that will solve both problems will go on and if a better product is found it will be used.) Do not be alarmed if the nose seal does come out of the unit. Use the opportunity to inspect the Wave Washers (2-19 or 19A) for damage. (Note that the newer designed Wave Washer (2-19A) is a single piece unit and replaces all four of the Wave Washers (2-19)). The Wave Washer (2-19A), single piece unit, is designed such that the ends of layers will be forced against the adjoining layers. Some washers have reached the field where the ends move away from the adjoining layers and into

the Nose Seal (2-17) or Body (2-5) causing it to move inward until it tends to jam the mechanism. The Wave Washer (2-19A) should be inspected to assure that it corrected arranged. Refer to Figure B for a graphic representation of the correct arrangement. If it is incorrect it can easily be change by turning it within itself. The seal O-ring (2-18) may also be replaced if it appears scrubbed. Reposition the Wave Washers (2-19) or (2-19A) and install the O-ring (2-18) onto the Nose Seal (17) prior to closing the Poppet (2-15).

H. Inspect the molded rubber Nose Seal (2-17) for damage, tears, etc. on both the adapter and poppet sealing surfaces.

NOTE:

1. THIS EDGE MUST BE ON TOP OF THE SPRING COIL.

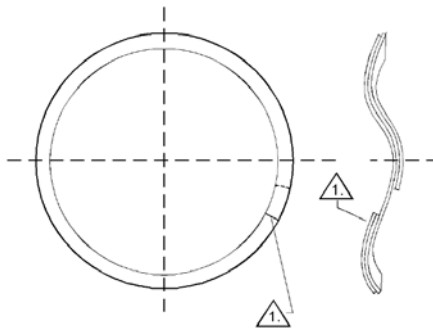

FIGURE B - Wave Washer (2-19A)

I. Depress the Collar Stop Assy (1-G) and verify that the Collar (2-27) cannot be retracted with the Poppet Operating Handle (2-1 or 1-B) in any position but the fully closed position.

J. With the Poppet (2-15) closed and the Collar Stop Assy (1-G) depressed, push the Collar (2-27) to the retracted position while observing that the spring loaded Detent Pin (2-26) extends and locks Collar (2-27).

K. With the Poppet (2-15) closed, precisely measure the distance between outer surface of

the molded seal and the adjacent surface of the coupler body at two places 180° apart. If the average of these two measurements exceeds 0.100 inch (2.54 mm), the internal linkages are excessively worn and the coupler should be withdrawn from service and completely overhauled.

L. Apply 60 psig minimum air pressure to unit connector. The Piston (3-5) should open. Maintain air pressure and using a flashlight, carefully inspect O-ring (3-12). With the air pressure maintained, place a bubble of liquid soap solution over vent port in Housing (3-23) at Screen (3-35) and observe for excessive leakage. A bubble may form with the soap solution. However, if the bubble quickly forms and breaks, the unit should be overhauled and Seal (3-19) and O-ring (3-20) need replacing. Relieve air pressure. Unit piston should close. Using the flashlight, inspect relief valve passage in unit Seal Retainer (3-8) and verify it is clean and not clogged.

M. If the unit contains Option C, Product Selection, inspect for security, effectiveness and damage. Verify that product selector bolt heads are flush to 0.03 inch (0.76 mm) below the adjacent Collar (2-27) surface.

N. Lubricate unit outlet O-ring (3-21) or Teflon Seal (4-9), as appropriate, with petroleum jelly. Reassemble and safety lock the female half quick disconnect per paragraph 7.1.F.

O. Check the mating flange on the Elbow (1-1A or 1B) with the Body (2-5) for damage to the threaded holes or the wall of the Elbow (1-1A or 1B). Check the wall between the inner diameter of the coupler upper half Elbow (1-1A or 1B) and the threaded holes. The diameter should be smooth and continuous with no evidence of bulging or hairline cracks. If the wall is bulged or cracked, the threads are already over stressed and the part is no longer safe for use. The coupler Elbow (1-1A or 1B) will have to be replaced. Reference Figure 12 for assistance. Check to be sure that the correct length of fasteners are being used on the Carriage Assembly (1-W) as noted in paragraph 10.6.

6.0 **Trouble Shooting And Minor Repair**

General trouble shooting analysis and minor repair actions are as follows:

6.1 **Trouble:** Collar (2-27) will not drop or extend during engagement.

Probable Cause:

- A. Coupler improperly positioned.
- B. Product Selection not mated or incorrectly set.

Remedy:

A. Use one hand to relieve hose weight while using the other hand to center and square coupler to adapter.

B. Rotate Collar (2-27) until Product Selection mates. If adapter flange incorporates a tab, align strip or arrow on Collar (2-27) with tab. Verify that adapter and coupler Product Selection is intended to mate.

C. Square coupling face to adapter to assure that the Detent Pin (2-26) is depressed. If hole in Body (2-5) in which Detent Pin (2-26) is housed is egg shaped it may be difficult to depress.

D. Collar (2-27) may be out of round.

6.2 Trouble: Poppet Operating Handle (2-1 or 1-B) cannot be moved in open direction.

Probable Cause: Collar (2-27) is not engaged, removing physical safety interlock between Poppet Operating Handle (2-1 or 1-B) and Collar (2-27).

Remedy: Fully engage Collar (2-27). See 6.1 above.

6.3 Trouble: Poppet Operating Handle (2-1 or 1-B) rotates easily for approximately 45° in the open direction and then a high resistance is felt.

Probable Cause: This is normal if the adapter is pressurized.

Remedy: Continue to apply moderate pressure to the Poppet Operating Handle (2-1 or 1-B) in the poppet open direction until the pressure equalizes and the poppet opens easily.

6.4 Trouble: External leak between Coupler Lower Half (1-5) flange and Pressure Control Elbow Assy (1-1A or 1B).

Probable Cause:

A. Flange Bolts (2-2) loose.

B. O-ring (2-10) damaged.

Remedy: Refer to Figures 1 and 2.

A. If Carriage Assembly (1-W) is present, before retightening the bolts, the Bolts (8-19) should be removed and the length of the shank checked. The length should be 1 19/32 ± 1/32 (40.5 mm). This applies to the four Bolts (8-19) affixing the Flange (6-9) to the unit. The other two Screws (2-2) should be 1 inch (25.4 mm) long. If the Bolts (8-19) are not the correct length, replace them with new ones from kit 80989. Tighten socket head Screws (2-2) or Bolts (8-19) to 90 ±10 inch pounds (104 ± 12 kg-cm) and recheck for leakage.

CAUTION!

If the Bolts (8-19) were not the proper length (too short) the threads in the Elbow (1-1A, 1B or 1C) may have already been damaged beyond use. See paragraph 10.7 for inspection procedure.

B. Replace O-ring (2-10) as follows:

1. Use suitable container to capture entrapped fuel. Verify coupler is depressurized. Remove six socket head Screws (2-2), six Washers (2-3), and Dust Cap (1-2).

2. Carefully separate Pressure Control Elbow Assy (1-1A, 1B or 1C) from coupling Body (2-5). Remove and discard O-ring (2-10).

3. Lubricate new O-ring (2-10) and carefully place over pilot on Body (2-5).

4. Carefully assemble Elbow Assy (1A, 1B or 1C) to Coupler Lower Half (1-5), reinstalling six Washers (2-3), Dust Cap (37) and six socket head Screws (2-2) or two Screws (2-2) and the four Bolts (8-19) if the Carriage Assembly (1-W) is used. Torque screws to 90 ± 10 inch pounds (104 ± 12 kg-cm).

5. Pressure check new O-ring installation at 5 and 150 psig fuel pressure, if possible. If not possible, carefully observe for leakage during next use.

6.5 Trouble: External leak between disconnect halves.

Probable Cause: Damaged O-ring (3-21) or Teflon Seal (4-9).

Remedy: Remove and replace O-ring (3-21) or Teflon Seal (4-9) as follows:

A. Use suitable container to capture entrapped fuel. Refer to paragraph 7.1 for correct method of separating disconnect.

B. With disconnect separated, remove and discard O-ring (3-21) or Teflon Seal (4-9). Lubricate with petroleum jelly and carefully install new O-ring (3-21) or Teflon Seal (4-9).

C. Reconnect, safety and lockwire disconnect assembly per paragraph 7.1.

D. Leak check at 5 and 150 psig fuel pressure if possible. If not, carefully observe joint during next operation.

6.6 Trouble: Leak at Poppet Operating Handle (2-1 or 1-B).

Probable Cause: O-ring (2-25) damaged, worn or scrubbed.

Remedy:

A. O-ring (2-25) can be replaced without removing the coupling from the hose, however, the dispenser may be out of service for a shorter time if the coupler is replaced with a spare coupler and repair is accomplished on the bench. The hose should be depressurized and drained. Separation of the disconnect may be the simplest method of draining the hose.

WARNING:

Assure that the hose is not pressurized.

B. With the coupler held over an adequately sized container, depress the Detent Pin (2-26) and extend the Collar (2-27), operate the Poppet Operating Handle (2-1 or 1-B) in the open direction, opening the Poppet (2-15) to drain the hose. Close the Poppet (2-15) when the hose is drained, depress Collar Stop Assy (1-G), if present, and retract the Collar (2-27) releasing the spring loaded Detent Pin (2-26).

C. Remove Bolt (2-6), lock Washer (2-7), and Washer (2-8). Remove poppet operating Handle (2-1 or 1-B), Key (2-9), and outer shaft seal Bearing (2-24). Use a sharp pointed instrument or pin to remove old O-ring (2-25). Lubricate new O-ring (2-25) with petroleum jelly or equivalent. Use clean, lint-free cloth dipped in clean fuel or solvent to clean the sealing surfaces of the Crank Shaft (2-20) and Body (2-5). Carefully install new, lubricated O-ring (2-25) using clean, smooth blunt instrument to seat it properly. Inspect O-ring (2-25) to verify that it is not twisted.

D. Reinstall outer shaft seal Bearing (2-24), poppet operating Handle (2-1 or 1-B), Key (2-9), Washer (2-8), lock Washer (2-7), and Bolt (2-6). Torque Bolt (2-6) to 90 ± 10 inch pounds (104 ± 12 Kg-Cm).

E. If possible, connect this coupler to a pressurized adapter and open Poppet (2-15). Observe the Crank Shaft (2-20) for leakage through several poppet opening and closing cycles.

6.7 Trouble: External leakage between unit and adapter or hydrant with unit engaged and Poppet (2-15) open.

Probable Cause:

- A. Damaged adapter sealing surface.
- B. Damaged Nose Seal (2-17).
- C. Damaged or worn O-ring (2-18).
- D. Missing, damaged, broken, or ineffectual Wave Washers (2-19 or 19A).

Remedy

- A. Replace or repair hydrant adapter.
- B. Inspect Nose Seal (2-17) for tears, abrasions, blisters, bond failure, etc. If none are found, proceed to Remedy (C). If seal is damaged or otherwise defective, remove coupler from service and replace Nose Seal (2-17) on the bench as follows:

1. Separate Pressure Control Elbow Assy (1-1A, 1B or 1C) from Coupler Lower Half (1-5) in accordance with paragraph 6.4, remedy B, steps 1 and 2.
2. Remove Cotter Pin (2-11), Washer (2-12) and Bearing (2-13). Rotate Link (2-16) slightly to free Link (2-16) from Crank Shaft (2-20). Slide Poppet (2-15), Pin (2-14) and Link (2-16) toward connection end of coupler until Pin (2-14) can be removed, separating Poppet (2-15) from Link (2-16).
3. For units with Poppet (2-15A) only. - Open Poppet (2-15A) by depressing Detent Pin (2-26) and sliding Collar (2-17) forward, then rotate Handle

(2-1) to the open position. Drain the unit in an appropriate basin or tank.

Remove Screws (2-15B) from Poppet Assembly (2-15A) using a torque wrench. The running torque to remove the Screws (2-15B) shall not be less than 6 in.-lb (6.9 kg.- cm.). Remove Poppet (2-15C) and O-ring (2-15D). Discard O-ring (2-15D). Continue on with paragraph 4 - 8.

4. Grasp Nose Seal (2-17) with fingers and pull it out of the Body (2-5) bore. Discard Nose Seal (2-17). Remove and discard O-ring (2-18). Use opportunity to inspect Wave Washers (2-19 or 19A) for damage and quantity. Inspect the Wave Washer (2-19A) in accordance with Figure B, paragraph 5.5G.

5. Use clean, lint-free cloth soaked in clean solvent or fuel to clean out Body (2-5) bore, and Poppet (2-15).

6. Lubricate new O-ring (2-18) with petroleum jelly and assemble it over new Nose Seal (2-17). Ensure that O-ring is not twisted.

7. Position Wave Washers (2-19 or 19A) in Body (2-5) bore.

NOTE: Once used, Wave Washers (2-19), if used, take a set which causes the wave pattern to form a different shape. If used, rotate the Wave Washers (2-19) to obtain the best fit between washers prior to installation. Some models use a two piece Wave Washer (2-19A) which is approximately one and one-half times a single piece unit. The unit is not broken, it is intended to be that way.

Carefully insert new Nose Seal (2-17) in Body (2-5) bore, ensuring that new O-ring is not pinched.

8. On units with Poppet Assembly (2-15A) (multi-piece units) - Assemble new O-ring (2-15D) to the Shaft (2-15E) after lightly lubricating it. Install Poppet (2-15C) to the Shaft (2-15E) and Screws (2-15B). Torque the Screws (2-15B) to 10 ± 1 in.-lbs. (11.5 ± 1 kg-cm). If running torque of Screws (2-15B) is less than 6 in.-lbs. (6.9 kg-cm) replace the Screws (2-15B) with new ones. Skip to paragraph 10.

9. Insert Link (2-16) into Body (2-5) bore so that bump on Link (2-16) is in the longest slot in bore. Place Poppet (2-15) clevis over Link (2-16) and insert Pin (2-14). Then press Poppet (2-15) back into bore so Pin (2-14) is captured. Slightly rotate Link (2-16) and insert Link (2-16) hole over lug of Crank Shaft (2-20). Slide Bearing (2-13) through hole in Link (2-16) and on to lug of the Crank Shaft (2-20). Fasten Link (2-16) and Bearing (2-13) to

the Crank Shaft (2-20) with Washer (2-12) and Cotter Pin (2-11).

10. Close and open Poppet (2-15) several times. Then close Poppet (2-15), depress Collar Stop Assy (1-G), if present, and retract Collar (2-27) to retracted position.

11. If removed reassemble Coupler Lower Half (1-5) to Pressure Control Elbow Assy (1-1A, 1B or 1C) and conduct coupler functional, proof pressure and leakage tests per paragraphs 12.4 and 12.5.

C. Replace damaged or worn O-ring (2-18) as follows:

1. Depressurize, drain fuel, and open Poppet (2-15) as described in paragraph 6.6.

WARNING:

Verify that coupler is not pressurized before opening Poppet (2-15).

2. With Poppet (2-15) open, carefully grasp Nose Seal (2-17) and pull out of Body (2-5).

NOTE: Nose Seal (2-17) cannot be pulled over Poppet (2-15).

3. Grasp old O-ring (2-18) and stretch until it passes over Nose Seal (2-17). Use clean, lint-free cloth soaked in clean solvent or fuel to clean sealing diameters of Nose Seal (2-17) and Body (2-5) bore. Lubricate a new O-ring with petroleum jelly and stretch until it passes over Nose Seal (2-17). Position new O-ring (2-18) on Nose Seal (2-17) sealing diameter and ensure that it is not twisted. Verify that the correct number of Wave Washers (2-19 or 19A) (four for 2-19 and one for 2-19A) are in proper Body (2-5) bore. Carefully press Nose Seal (2-17) into Body (2-5) bore, exerting care to prevent pinching O-ring (2-18).

4. Close and open Poppet (2-15) several times. Then, depress Collar Stop Assy (1-G), if present, and retract Collar (2-27), ensuring that Detent Pin (2-26) has extended, and locked Collar (2-27).

5. If possible, test seal by connecting coupler to pressurized adapter and observing interface for leakage.

D. Damaged, broken or ineffectual Wave Washers (2-19 or 19A): Proceed as in (C) above, to inspect Wave Washers (2-19 or 19A). If any of the Wave Washers (2-19 or 19A) are damaged, cracked, or broken, proceed as in (B)

remedy (above) to replace damaged Wave Washers (2-19 or 19A), and do not replace Nose Seal (2-17) unless it is also damaged.

6.8 **Trouble:** Leakage past Poppet (2-15) seal with coupler disengaged.

Probable Cause:

A. Damaged Poppet (2-15) sealing surface.

B. Damaged molded rubber on Nose Seal (2-17).

Remedy:

Isolate problem by reducing pressure in the unit and draining unit, and opening poppet as described in paragraph 5.6. Inspect Poppet (2-15) or (2-15C) sealing surface and Nose Seal (2-17). Replace damaged component or components per paragraph 5.7 remedy B. Disassemble only to the extent necessary to replace either the Poppet (2-15) or (2-15C) or Nose Seal (2-17). Replace O-ring (2-18) if Nose Seal (2-17) is replaced

6.9 **Trouble:** Excess force required during last portion of poppet closing travel.

Probable Cause:

A. Steady force had not been applied to poppet operating Handle (2-1 or 1-B) long enough to permit relief valve to vent trapped fluid downstream, relieving the hydraulic lock.

B. Pressure trapped downstream of unit.

C. Relief Valve (3-37 through 50) improperly adjusted.

D. Relief valve passages clogged with foreign matter or unit piston Seat Retainer (3-8) is mis-installed so that relief valve passage is blocked.

Remedy:

A. Apply steady moderate force until poppet closes.

B. Vent trapped pressure.

C. Maintain steady force on poppet Handle 2-1 or 1-B) and momentarily actuate deadman valve to relieve hydraulic lock and close poppet to permit coupling disengagement. Then, remove the unit from service for bench correction. Disassemble only to the extent necessary to readjust relief valve or clean clogged passages. Refer to paragraphs 9.3 and 11.5.1 for relief valve adjustment, disassembly, and reassembly instructions if necessary. Bench static pressure test all seals that are broken during disassembly.

6.10 **Trouble:**

Unit does not open or opens very slowly (several minutes), when deadman air valve is actuated.

Probable Cause:

- A. Coupler poppet has not been opened.
- B. Deadman air pressure too low to overcome piston spring.
- C. Air pressure hose or passages clogged.
- D. Air orifice clogged.
- E. Clogged orifice in restrictor Check Valve (3-24 through 30).
- F. Locked in downstream pressure has unit shut off.

Remedy:

- A. Open coupler poppet.
- B. Increase deadman air pressure to 60 psi minimum.
- C. Loosen air hose connection at unit connector and verify that air pressure is reaching unit. If it is not, replace or clean out air pressure hose.
- D. Refer to Figure 3A. Remove Connector (3-32). Check to see which orifice combination is installed as follows:

- If the fixed orifice Screw (3-33) is present, the head of the Screw (3-33) will be one of the slotted variety and will be visible in the port.
- If the adjustable Needle (3-33A) is present, the Needle (3-33A) will have an Allen key head.
- If the latest adjustable orifice is present, the Screw (3-33C) will have an Allen key type head and a Spring (3-33D) will be installed under the Screw (3-33C).

(1) If Screw (3-33) is present, use a screwdriver to remove it. Use a small wire to clean out the hole in the air orifice Screw (3-33). Reinstall using O-ring (3-34) as the seal.

(2) If adjustable Needle (3-33A) and Orifice Screw (3-33B) are present, using an Allen key remove Needle (3-33A) and Orifice Screw (3-33B). Clean out Orifice Screw (3-33B). Reinstall the air Orifice (33A) in accordance with the instructions noted in paragraph 11.5.1.K.

(3) If adjustable Screw (3-33C) and Spring (3-33D) are present use an Allen key to remove the Screw (3-33C). Carefully clean out the slot in the thread of the Screw (3-33C). Adjust the position of the Screw (3-33C) in accordance with the instructions in paragraph 11.5.1.K., then re-install the Connector (3-32).

CAUTION:

Never operate the unit without air orifice Screw (3-33), Orifice Screw (3-33B) and Needle (3-33A) or Screw (3-33C) and Spring (3-33D) installed. Operation without the air orifice Screw (3-33) or Orifice Screw (3-33B) and Needle (3-33A) or Screw (3-33C) can result in propagation of destructive pressure surges into the hydrant system when the deadman air valve is released. The unit is direct operated and, without the air orifice Screw (3-33), Orifice Screw (3-33B) and Needle (3-33A) or Screw (3-33C) and Spring (3-33D), the closing rate is very fast.

- E. Remove and clean restrictor Check Valve (3-24 through 30) as follows: Refer to Figure 3A.

(1) Isolate fuel sense line and capture fuel in a suitable container. Remove check valve Housing (3-24), or Fitting (3-24A) and Housing (3-24B), exerting care to contain the Check Valve (3-30), Spring Guide (3-28), and Springs (3-27 & 3-29).

(2) Place Check Valve (3-30) in container of clean fuel and agitate to wash out material clogging orifice hole.

(3) Reinstall Springs (3-27 & 3-29), Spring Guide (3-28), Check Valve (3-30), and check valve Housing (3-24), or Fitting (3-24A) and Housing (3-24B). Reactivate fuel sense line. If necessary, fill fuel sense line and passages with fuel and bleed air prior to use.

- F. Unit will open when downstream pressure is relieved by initiating flow.

6.11

Trouble:

Deadman air valve release shutdown is slow.

Probable Cause:

Deadman air valve is restricting release of air, hose diameters are small and/or hose is exceptionally long or kinked. Unit orifice is clogged.

Remedy:

Open up deadman air valve vent passages, increase hose inside diameter and/or shorten hose, remove kinks. Refer to paragraph 6.10, remedy D for orifice cleaning instructions.

6.12

Trouble:

- A. Unit does not close when deadman valve is released following defuel operation.

- B. Unit does not regulate during normal refuel operations following a defuel operation, but acts as simple deadman fuel shutoff valve.

Probable Cause:

A. Servicer incorporates defuel selector valve similar to that discussed in paragraph 4.2.3.1 which is stuck in "defuel" position.

B. Fuel sense line not reconnected after defueling per paragraph 4.2.3.2

Remedy:

Reselect "normal" position of selector valve or reconnect and bleed fuel sense hose per paragraph 7.5.

6.13

Trouble:

Unit opens and then abruptly shuts off when deadman air valve is actuated.

Probable Cause:

Downstream system is blocked.

Remedy:

Open nozzle(s) or other valve blocking flow.

6.14

Trouble:

Unit either does not open, or shuts off early during defuel operations.

Probable Cause:

Defuel pressure, transmitted back through the fuel sense line, has caused unit to shut off.

Remedy:

A. Increase air pressure to a value that is at least 30 psi above the maximum defuel pressure.

B. If A is not practical, proceed per 4.2.3 and subparagraphs.

6.15

Trouble:

Regulated pressure is lower at high flow rates than at low flow rates.

Probable Cause:

None. This is normal for a normally closed direct operated regulator of this type. As the piston opens further, the bias force exerted by the piston spring increases, resulting in lower regulated fuel pressure.

Remedy:

If a remedy is required and adequate hydrant pressure is available, increase the air pressure to achieve the desired regulated pressure at the desired flow rate with the full knowledge that the low flow rate regulated (and normal shutoff) pressures will be higher.

6.16

Trouble:

Regulated pressure is low at high flow rates. Increasing the air pressure does not increase regulated fuel pressure.

Probable Cause:

Hydrant pressure is insufficient to overcome system resistance at high flow rates and regulator is fully open.

Remedy: None unless hydrant pressure can be increased or system resistance reduced.

6.17

Trouble:

Desired regulated pressure is achieved, but flow rate is considered low.

Probable Cause:

Aircraft resistance equals regulated pressure at maximum flow rate.

Remedy:

None unless aircraft operator will agree to increase in regulated pressure

6.18

Trouble:

Unit appears to jump open or otherwise act erratically when deadman air is applied.

Probable Cause:

Fuel sense line and/or fuel control passages contain air.

Remedy:

Shut down. Fill fuel sense system and bleed air per 7.5.

6.19

Trouble: Pressure regulation band is wide.

Probable Cause:

A. Fuel sense line is clogged, leaking, or kinked and/or restrictor portion of restrictor Check Valve (3-24 through 30) is clogged.

B. Regulated pressure band is inherent in simple, direct operated type unit.

Remedy:

A. Correct problem with fuel sense line by inspection and repair or replacement, or clean restrictor Check Valve (3-24 through 30) per paragraph 6.10, remedy E.

B. The regulated pressure band of a normally closed direct operating pressure regulator is inherently relatively wide because of the change in bias force of the piston spring as the regulator moves from closed to open and (with relatively high hydrant pressure) the forces imposed by piston seal drag (whose effect is generally known as hysteresis).

All of this results in a drop in regulated pressure as the regulator opens to high flow rates and an increase in regulated pressure as the regulator progressively moves in the closed direction as the aircraft tanks fill and shutoff. In most applications these characteristics are not detrimental since the change in flow rate is only proportional to the square root of the change in regulated pressure and relatively large pressure changes do not result in equivalent changes in flow rate.

However, if more precise regulation is considered mandatory, then consideration should be given to the Eaton Carter brand Model 60600 and 60600-2 Pressure Control Couplers and the Model 60600-1 and 60600-3 Pressure Control Couplers with single or dual excess flow control. The Model 60600 series of couplers incorporate pilot operated, adjustable bias regulators which maintain regulated pressure at plus or minus 2 psi of the set pressure at all flow rates from 100 - 1200 U.S. gpm.

6.20

Trouble:

Excessive internal fuel leakage.

Probable Cause:

- A. Inlet pressure is above 200 psi and relief valve is relieving.
- B. Deadman air pressure is not completely relieved.
- C. Foreign object is holding unit outer piston off seat.
- D. Unit seal leakage.

Remedy:

- A. Decrease inlet pressure to less than 175 psi.
- B. Completely vent deadman air pressure.
- C. Remove unit from hose by disconnecting female half quick disconnect per paragraph 7.1, exercising all specified safety provisions. Apply deadman air pressure to fully open Outer Piston (3-5); use pliers or other gripping tool to remove foreign object; and then release deadman air pressure to close unit. Reinstall on hose by connecting female half quick disconnect per paragraph 7.1.

WARNING:
Do not insert fingers into valve while deadman air is holding piston open. Accidental release of deadman air could result in finger amputation or other personal injury. **Always** use needle nose pliers or other grasping tool if practicing this remedy.

- C. Remove unit from service and place on test bench to isolate leak path to one of the following by applying 150 psi inlet pressure with the deadman air released while observing for leakage through the open unit outlet.

WARNING:
Wear safety glasses or other eye protection while inspecting outlet for leakage.

- 1. Past Outer Piston (3-5) Seal (3-3).
- 2. Past Outer Piston (3-5) seat O-ring (3-12).

- 3. Through relief valve hole in piston seat Retainer (3-8).

Then, use the applicable portions of Section 9.0 to disassemble, clean, remove and replace, or polish the defective seal, O-ring, seat, or sealing surface causing the noted leakage. Leakage at point 3 above could result from omission of O-rings (3-41, 3-42) or Spring (3-37) during assembly after overhaul.

6.21

Trouble:

Unit closing rates are too fast.

Probable Cause:

Air orifice screw was not installed during overhaul.

Remedy:

Install air Orifice Screw (3-33C) and Spring (3-33D), Orifice Screw (3-33B) and Needle (3-33A) or Screw (3-33) using procedure of paragraph 6.10, remedy D. Observe **WARNING** in paragraph 6.10, remedy D.

6.22

Trouble:

Coupler poppet linkage does not cause relief valve to relieve hydraulic lock and vent trapped fluid downstream of closed unit piston seat.

Probable Cause:

- A. Relief Valve (3-37 through 50) is not correctly adjusted.
- B. Piston seat Retainer (3-8) was not installed so that relief valve hole in retainer lines up with relief valve hole in Housing (3-23).

Remedies:

- A. Readjust relief valve per paragraph 11.5.1.N.
- B. Loosen four Screws (3-6) and Washers (3-7). Grasp Outer Piston (3-5) and pull out a small amount. Rotate piston seat Retainer (3-8) 90° or 180° as required to line up relief valve holes. Reinstall Washers (3-7) and Screws (3-6). Tighten Screws (3-6) to pull piston seat Retainer (3-8) down tight. (90±10 in-lbs, 104±12 kg-cm).

6.23

Trouble:

Collar (2-27) will not deploy to allow connection to the hydrant valve or adapter.

Probably Cause:

The Detent Pin (2-26) may be worn in one location on its angular portion preventing the Ball (2-30) from moving into the hole in the Body (2-5).

Remedies: A short term remedy is to rotate the Pin (2-26). A more positive remedy is to replace it.

6.24

Trouble:

Collar (2-27) will not move to the stowed position or is difficult to move.

Probably Cause:

The Detent Pin (2-26) is worn on the outer diameter on the spring end of the pin.

Remedies:

A short term remedy is to rotate the Pin (2-26). A more positive remedy is to replace it.

7.0 Installation

Installation of the Coupler consists of connecting the outlet to the pickup hose and connecting the deadman air and fuel sense hoses to the unit connector hose fittings. Proceed as follows:

7.1 Pickup Hose Connection

The installation of the 4-inch coupler to the hose is contingent of the optional outlet arrangement incorporated in the specific unit. The Pressure Control Elbow Assy (1-1A or 1C) with its male half quick disconnect will connect to any of the five various sized outlet threaded female half quick disconnects with carrying handle, Options K-N and P. Pressure Control Elbow Assy (1-1B) will mate with either Option R or S. A proper pipe thread lubricant should be used when tightening the female half quick disconnect to the hose thread.

Holes have been provided in the Screws (4-3) used to lock the Retainer (4-4) in place. It is recommended that these screws be lockwired to further prevent loosening during service.

A. Observe the method of lockwire securing the two Screws (4-3) to assure correct reassembly. Break Lockwire (4-2) and remove the two Screws (4-3). Remove Retainer (4-4). Note that Housing (4-5) incorporates two lock ring grooves. If Lock Ring (4-1) is installed in outer groove, away from ball retaining Sleeve (4-6), proceed to step B. If Lock Ring (4-1) is installed in safety inner groove on Housing (4-5), adjacent to ball retaining Sleeve (4-6), spread Lock Ring (4-1) until it may be moved into full engagement in the second (outer) groove.

B. Grasp outside diameter of the ball retaining Sleeve (4-6) with the fingers while using the thumbs to spread the ends of the Retainer Ring (4-7). Slide ball retaining Sleeve (4-6) back until stopped by the Lock ring (4-1) in the Housing (4-5) groove. This action allows the 24 Balls (4-8) to disengage from the mating groove in the appropriate Pressure Control Elbow Assy (1-1A, 1B or 1C). The two parts may now be separated. Note: The O-ring (3-21) utilized, in Elbow Assy (1-1A or 1C), to seal the joint between the two halves will provide considerable resistance to separation. The Teflon Seal used in Options R and S will separate easier. Axial force and twisting of the two halves in opposite directions will aid in this operation.

C. When the Female Half Quick Disconnect (Option K,L,M,N,P,R or S) is disengaged, move

ball retainer Sleeve (4-6) back to engaged position and temporarily reinstall Ring Retainer (4-4) and two Screws (4-3) to prevent loss of the parts.

Inspect the hose fitting male threads for dirt and damage. Clean and repair threads as necessary. Apply anti seize compound. For Options L or N (BSPP threads) install a proper sized gasket (not furnished by Eaton) in the proper position. Use the wrench flats on the female Housing (4-5) to tighten the female half to the hose fitting.

Reconnect, safety lock and lockwire the female half quick disconnect to the Pressure Control Elbow Assy (1-1A, 1B or 1C) as follows. Refer to Figures 1, 4A and 4B.

WARNING:

Improper (or omission of) safety locking and lockwiring of the female half quick disconnect can result in accidental separation of the disconnect at high pressures and/or flow rates resulting in a potentially unsafe and undesirable product spill that could result in personal injury.

D. Remove the temporarily installed Screws (4-3), and Ring Retainer (4-4). Place the ball retainer Sleeve (4-6) in the retracted position as described in B, above.

E. Assure that O-ring (3-21) or Teflon Seal (4-9) is lubricated with petroleum jelly. Press forward (away from hose) on ball retainer Sleeve (4-6) while spreading Retainer Ring (4-7) with thumbs while sliding female quick disconnect assembly over outlet of Pressure Control Elbow Assy (1-1A, 1B or 1C) until Balls (4-8) pass into ball race of Pressure Control Elbow Assy (1-1A, 1B or 1C) housing and retaining Sleeve (4-6) will suddenly snap forward to the engaged position. Release the ends of Retainer Ring (4-7) to allow it to snap into the housing groove.

F. Install Ring Retainer (4-4) so that two of its holes capture the ends of the Retainer Ring (4-7) while the other two holes line up with the threaded holes in Sleeve (4-6). Fasten Ring Retainer (4-4) with two Screws (4-3). Before lockwiring the two screws together, grasp Sleeve (4-6) at two places, without touching Retainer Ring (4-7), and attempt to move Sleeve (4-6) to the disengaged position.

Caution:

If Sleeve (4-6) can be moved toward the disengaged position, or can be partially cocked, the female half quick disconnect is unsafe for use and should be withdrawn from service until the cause is found and corrected.

One probable cause is mishandling that has resulted in permanent deformation of the tips of Retainer Ring (4-7) which has bent them toward each other. If bent sufficiently, then the installation of the Ring Retainer (4-4) will hold Retainer Ring (4-7) in the spread position so it is not fully engaged in the housing groove.

Lockwire two Screws (4-3), to each other with 0.020 inch stainless steel lockwire in a manner that backing out of the screws results in the lockwire being tightened.

G. Be sure and move Lock Ring (4-1) to safety groove nearest Sleeve (4-6). Verify that Lock Ring (4-1) is fully engaged in safety groove.

WARNING:

Omission, or loss, of Ring Retainer (4-4) can result in accidental separation of the quick disconnect under high flow conditions. Under no condition should the disconnect be used without the Ring Retainer (4-4) locking the end of the Retainer Ring (4-7) and the Screws (4-3), securely lockwired.

7.2 **Deadman Air and Fuel Sense Connections**

Connect the deadman air hose to Connector (3-32) and connect the fuel sense hose to Check Valve Housing (3-24) or Fitting (3-24A).

7.3 **Product Selector Set**

If unit contains Option C, Product Selection, verify that set is correctly positioned for desired product. If it is not, reposition required Bolt (1-C) and verify that bolt head is flush to 0.03 inch (0.76 mm) below the adjacent Collar (2-27) surface.

7.4 **Installation Inspection**

Verify security of installation, reinstallation and lockwiring of female half quick disconnect retainer Screws (4-3), and correct positioning of

disconnect lock Ring (4-1). See WARNING in paragraph 7.1 G.

7.5 **Initial Installation Preparation**

Following the initial installation of the fuel pressure control coupler, it is necessary to fill the fuel pressure control passages with fuel, and to bleed air from these passages and from the fuel sense hose to prevent erratic operation of the fuel pressure control valve (Pressure Control Elbow Assy (1-1A, 1B or 1C)). A Bleed Valve (3-30) has been provided in the boss containing the Check Valve Housing (3-24) to simplify and shorten the time required for this process.

While the detailed fill and bleed methods may understandably vary according to the detail design of the servicer or dispenser on which the unit is installed, the following general procedure is one practical method of filling and bleeding the Pressure Control Elbow Assy (1-1A, 1B or 1C) following field replacement of the unit. Of course, if the unit is installed on a new servicer that is completely empty, this procedure should not be used since a more rapid method of filling the entire dispenser volume is desirable.

A. Place the coupler face over a hydrant pit valve adapter. Use one hand to relieve hose weight bending forces so that coupler face is centered and square to the adapter, so the Detent Pin (2-26) is depressed and the Collar (2-27) drops.

B. Adjust the deadman air pressure to 60 psig and actuate the deadman valve to open the Pressure Control Elbow Assy (1-1A, 1B or 1C) piston. Then rotate the coupling Poppet Operating Handle (2-1 or 1-B) in the open direction only far enough to open the adapter's pressure equalizing valve to establish approximately 10 psig pressure at the fuel sense connection to the Pressure Control Elbow Assy (1-1A, 1B or 1C), then release the Poppet Operating Handle (2-1 or 1-B). Use the blade of a large screwdriver to hold the Pressure Control Elbow Assy (1-1A, 1B or 1C) Bleed Valve (3-30) open until only fuel (with no air) is observed at the bleed valve. If necessary, momentarily reopen the adapter equalizing valve to reapply 10 psig pressure to the fuel sense connection.

C. When all air has been bled, release the bleed valve and then release the deadman air valve and proceed with normal operation commencing with step 4.1.

8.0 **Special Tools**

The following special Eaton Carter brand tools are recommended for use during the maintenance of the coupler:

- 61362 Wear Gauge - Inspects completely assembled couplers to indicate wear.

- 60505D or 61526D - 4" API Adapter for use in testing the unit.
- AF42208-1 - Seal polishing run-in tool.

9.0 **Disassembly**

Refer to Figures 1-6 for explode views of the unit to assist in disassembly. The numbers mentioned herein are those shown in one of these figures.

9.1 Outlet Connection To Hose

Refer to Figure 3A. Unless there is a need to replace or repair any parts of the female half of the quick disconnect, it may be left on the hose. Excessive wear of the inside diameter of the Sleeve (4-6) can be a cause of external leakage from the O-ring (3-21) or Teflon Seal (4-9). Removal of the coupler from the female half quick disconnect may be accomplished in the following manner:

A. Note the method used to lockwire the two Screws (4-3) to assure correct reassembly. Break the Lockwire (4-2) and remove the Screws (4-3). Remove the Retainer Plate (4-4). Note that the Housing (4-5) incorporates two lock ring grooves. The Lock Ring (4-1) should be installed in the groove closest to the Sleeve (4-6) during operation. Move it to the groove farthest from the Sleeve (4-6).

B. Grasp the outside diameter of the Sleeve (4-6) with the fingers while using the thumbs to spread the ends of the Retaining Ring (4-7). The Sleeve (4-6) may then be moved toward the outlet (hose) end of the unit until stopped by the Lock Ring (4-1), unloading the Balls (4-8) that lock the coupler to the quick disconnect. The Female Half Quick Disconnect (1-K-N & P) may be removed from the coupler. Considerable force may be required due to the presence of an O-ring seal used between the two halves.

C. Remove the Lock Ring (4-1) from the Housing (4-5). Spread the Retaining Ring (4-7) to keep it from catching in either of the other two grooves in the Housing (4-5) as you slide the Sleeve (4-6) off of the Housing (4-5). Take care to catch the Balls (4-8) in a container to prevent losing them as the Sleeve (4-6) releases them.

D. If Option R or S is being disassembled, the Teflon Seal (4-9), contained within the Housing (4-5) need not be removed unless it is to be replaced due to observed leakage.

9.2 Product Selection Set

If the unit incorporated option C, Product Selection, it is not necessary to remove the Bolts (1-C) from the Collar (2-27) unless there is apparent damage to one of the Bolts (1-C) or the position desired is to be changed. Note that there are six potential positions, numbered 1 through 6. There are two other unmarked slots. The mating unit should have three studs or bolts protruding from it that match the three slots in which there are no bolts. The numbered position that has no bolt is the **set** position.

9.3 Pressure Control Elbow Assembly

Refer to Figures 1 & 3 to identify the part numbers. Newer units have been changed to

eliminate the Lockwire (4-2) from the Screws (2-2) unless option D is ordered. Self-locking thread inserts have been installed within the Elbow (1-1A, 1B or 1C) to provide the locking. The Screws (2-2) still retain the holes for lock wire purposes at the option of the customer or furnished when option D is ordered. Remove the Lockwire (4-2), if present, Screws (2-2) and Washers (2-3). The Dust Cap (1-2) will be removed with these items also. If present, removal of the Collar Stop Assembly (1-G) will also be achieved. Set the Collar Stop Assembly (1-G) aside for now. Separate Coupler (1-5) from the Pressure Control Elbow Assy (1-1A, 1B or 1C). Remove and discard O-ring (3-21), if present. Do not remove the Wear Rings (3-22) unless replacement is necessary.

A. Loosen Lock Nut (3-44) and remove Pressure Relief Adjusting Screw (3-43) and assembled parts, while containing and removing Pressure Relief Valve Spring (3-37).

B. Remove Lock Nut (3-38), Washer (3-39), Seal Retainer (3-40), O-rings (3-41 & 42), Pressure Relief Adjusting Screw (3-43) and Lock Nut (3-44) from Pressure Relief Shaft Assembly (3-45).

C. Remove Connector (3-32) and use an Allen key to remove Orifice Screw (3-33C) [or Orifice Needle (3-33A) or a screwdriver to remove air Orifice Screw (3-33). Use the same Allen key to remove Orifice Screw (3-33B), if present.] Remove Check Valve Housing (3-24) or (3-24B) (Fitting (3-24A) will also have to be removed, if present) with Check Valve (3-26), Bleed Valve Spring (3-29) and Check Valve Spring (3-27). Remove O-rings (3-25A & 25B) from Bleed Valve (3-30) and Check Valve (3-26). It is recommended that the orifice in Check Valve (3-26) be checked for size. If it is larger than 0.020 (0.508 mm) in diameter it should be replaced with a new one with such a diameter or smaller.

D. Rotate Outer Piston (3-5), if necessary, to gain access to the four Screws (3-6). Screw (3-6) is a self locking type screw that utilizes a nylon insert in the threads to affect the resistance required to provide the locking. They are designed to be reused a minimum of 15 times before losing their locking effectivity. Using a torque wrench, remove Screw (3-6) from the Housing (3-23), measuring the torque during removal. If the torque is less than 2 in lbs (0.023 m kg) discard the screw and replace it with a new one during reassembly. Remove Washer (3-7). Grasp Outer Piston (3-5) and pull it from the outlet of the Unit.

WARNING

Before proceeding further, beware that the Outer Piston (3-5) and the attaching parts are heavily spring loaded and that a vise will be required to safely disassemble this part of the unit.

E. Either a vise or parallel woodworker's clamp is required to proceed further. Wood blocks should be used to secure the entire assembly such that axial compression is exerted, yet there is accessibility to both of the Nuts (3-1).

CAUTION

Be sure that the assembly is securely held in place and can not slip, allowing the unit to forcibly separate when the first Nut (3-1) is removed. Forcible separation may cause personal injury and will damage some parts beyond repair.

NOTE:

Be careful not to damage the sealing surfaces of the Outer Piston (3-5), Piston Shaft (3-15) or Inner Piston (3-18). Protect these sealing surfaces during and after disassembly. Damage to these surfaces will cause leakage and may cause regulator malfunction.

F. With the assembly securely clamped in place, carefully remove Nut (3-1) from the opposite end of the Outer Piston (3-5). Remove Washer (3-2).

G. Slowly open the clamping device, allowing internal spring force to cause the Inner Piston (3-18) to follow the clamp until all spring force is relieved. Then, carefully remove the clamp. Lift Inner Piston (3-18) from the piston Spring (3-14) and remove the Spring (3-14). Remove O-ring (3-17) and Washer (3-16). Slide Spring Guide (3-13) and Retainer (3-8) from the Shaft (3-15).

H. Using two thin 3/8-24 UNF-2B nuts as jam nuts on the Shaft (3-15) at the opposite end to the Outer Piston (3-5), remove Nut (3-1) and Washer (3-2) retaining the Outer Piston (3-5). Remove Outer Piston (3-5) from Shaft (3-15).

I. On all older units (serial numbers lower than 2400 - on units with serial number greater than 2400 skip to paragraph J.) - Remove Piston Seal (3-3) and O-rings (3-4) (3-11), and (3-12) from Housing (3-23). Remove Shaft Seal (3-10) and O-ring (3-9) from Retainer (3-8). Remove Inner Piston Seals (3-19) and O-rings (3-20) from internal grooves in Housing (3-23). Be careful in removing these not to damage Housing (3-23).

J. On all units with serial numbers greater than 2400 - Remove Piston Seal (3-3) and O-rings (3-4) (3-11), and (3-12) from Housing (3-23). Remove Shaft Seal (3-10) and O-ring (3-9) from Retainer (3-8). Note: Seal (3-10) on later units is designed to "snap" into place and it may be a little difficult to remove it. Discard it after removal. Remove Screws (3-23B) and pull Housing (3-23A) from main Housing (elbow) (3-23). Remove and discard Inner Piston Seal (3-19) and O-rings (3-20) from the internal grooves in Housing (3-23A), being careful not to damage the surrounding surfaces of Housing (3-23A). Remove and discard O-rings (3-23C).

K. Complete the disassembly of the unit by removing Retaining Ring (3-36) and Filter Disc (3-35).

9.4 **Pre-Disassembly Inspection Of Coupler Subassembly**

It is recommended that Coupler Wear Gauge, part number 61362, be utilized prior to disassembly of the coupler. The wear gauge is designed to give a quick, convenient and accurate method of checking aggregate wear of all related parts in the coupler. The following instructions are provided to assist in utilizing the wear gauge:

A. **Installation** - Place the Wear Gauge into the inlet of the coupler with the pins of the gauge pointing toward the coupler inlet.

Note:

Be sure that the pins do not rest on the coupler Detent Pin (2-26).

Extend the Collar (2-27) to the locked-on position and open the Poppet (2-15). This must be done to simulate a coupler locked onto a hydrant valve.

Note:

This operation should be done with a catch basin under the coupler so as not to spill fuel trapped inside the coupler.

B. **Operation** - Once the Wear Gauge is in place, all four (4) gauge pins of the gauge should be above the exposed gauge surface. Slowly rotate the Collar (2-27) while bearing on one side of the Collar (2-27). Note the position of the gauge pins as the rotation is accomplished. Should any one of the four pins become flush or receded below the gauge surface, the coupler exhibits excessive wear and should not be used again until overhauled. See note below. Pay particular attention to the detailed inspection of the Collar (2-27), Body (2-5), Lugs (2-33) and Lug Rings (2-32) during the following maintenance procedure.

Note: Should only one pin (of the gauge) indicate wear, it is suggested that the gauge be removed and turned approximately one-fourth turn and the inspection be repeated. There may be a local indentation in the surface of the Body (2-5) on which the pin rests, causing a false reading.

9.5 **Coupler**

Refer to Figures 1 and 2 to identify the part numbers. Remove O-ring (2-10) and discard. Remove Bolt (2-6) and Washers (2-7 & 8) from Handle (2-1 or 1-B). Poppet (2-15) should be open for the following actions. Remove Handle (2-1) or Handle Assembly (1-B) and Woodruff Key (2-9).

9.5.1 **Collar Stop Assembly (1-G)** - Note how Torsion Spring (5-3) is installed to facilitate reassembly. Remove Cotter Pin (5-5). Push out Hinge Pin (5-

4), separating Collar Stop (5-1), Torsion Spring (5-3) and Bracket (5-2). Spring should be replaced if it is distorted or weak.

- 9.5.2 **Folding Handle Assembly (1-B) - Do not disassemble the Folding Handle Assembly (1-B) unless one or more parts are damaged and require replacement. It is necessary that Spring (1-8) be replaced whenever the Folding Handle (1-B) is disassembled.**

Place the assembly in a small, soft-jawed vice so that the jaws grip the boss of the Handle Cam.

Caution:

Do not over tighten vise as this may collapse or damage handle cam.

Insert large blade screwdriver in clevis end of Pin (1-6). Rotate Pin (1-6) slightly in a counterclockwise direction to release torsion on Cotter Pin (1-7). Remove Cotter Pin (1-7).

Caution:

Maintain a restraining torque on Pin (1-6) with screwdriver to prevent spring's tendency to unwind following Cotter Pin (1-7) removal. Gradually release Spring (1-8) torsion by slowly allowing Pin (1-6) to rotate the inserted screwdriver until the Spring (1-8) torque has been relieved.

Remove Pin (1-6) by pressing on either end. With Pin (1-6) removed, Handle (1-11) and Spring (1-8) may be separated from Handle Cam (1-10).

- 9.5.3 **Coupler Subassembly (1-5) - Disassemble Coupler Subassembly (1-5) as follows:**

Remove Cotter Pin (2-11) and Washer (2-12) from Crank Shaft (2-20). Rotate Link (2-16) slightly and disengage Link (2-16) from Crank (2-20). Remove Bearing (2-13). Press Poppet (2-15) and Link (2-16) far enough out of the coupler outlet end to remove Pin (2-14). Then withdraw Poppet (2-15) and Link (2-16) from opposite ends of the coupler.

Note: Newer units will utilize a multi-piece Poppet Assembly (2-15A). This can be determined by the presence of the four Screws (2-15B) in the face of the unit. Do not disassemble Poppet Assembly (2-15A), if present, unless a part of the unit is to be replaced.

If disassembly of the Poppet Assembly (2-15A) is required do so by removing the four Screws (2-15B). Remove these Screws (2-15B) using a torque wrench noting the running torque as they are removed. If the running torque is less than 6 in.-lbs. (6.9 kg-cm), discard the Screws (2-15B). Remove and discard O-ring (15D).

Remove Seal (2-17), O-ring (2-18) and four Wave Washers (2-19) or one (2-19A). Note: In older units that utilize an O-ring instead of the Quad-ring (2-18) there may have been only three Wave Washers (2-19). A Quad-ring may also be in use instead of the O-ring (2-18). It is recommended that four Wave Washers (2-19) or the newer single Wave Washer pack (2-19A) be utilized to improve sealing capability. Note: In some units a two piece wave washer was used in the transition period between the use of the four and the single piece units. The use of the two pieces (one is approximately half of the size of the other piece used) produced the same force as the current single piece unit. When replacing Wave Washers (2-19) or the two piece unit, always replace either with the newer 2-19A.

Discard the O-ring (2-18) (or Quad-ring, if present).

Rotate the Crank Shaft (2-20) and press down so it enters cavity cast into Body (2-5), then tilt Crank Shaft (2-20) and remove it along with Bearing Washer (2-21). Remove Bearing Washer (2-21) from Crank Shaft (2-20).

Remove Bearing (2-22). Remove one Shaft Seal Bearing (2-24), O-ring (2-25), second Shaft Seal Bearing (2-24) and Shaft Bearing (2-23). Discard O-ring (2-25).

Depress Detent Pin (2-26) and pull Collar (2-27) with Bumper (2-28) to extended position. Remove Retainer Ring (2-29). Withdraw Collar (2-27) over opposite end of Body (2-5). Ball Bearing (2-30) will fall out. Locate and secure Ball Bearing (2-30). **Do not** remove Bumper (2-28) from Collar (2-27) unless it is to be replaced. If Bumper (2-28) requires replacement, use a sharp cutting tool to cut it away from Collar (2-27).

Warning

Use extreme care to prevent personal injury while cutting Bumper (2-28) from Collar (2-27).

Remove four Lug Rings (2-32) each with four Lugs (2-33) attached from Body (2-5). Remove Lugs (2-33) from Lug Ring (2-32).

Insert a metal rod of 5/32 inch (3.9 mm) or smaller diameter in hole in Detent Pin (2-26) to prevent Detent Pin (2-26) from turning while unscrewing Bolt (2-34).

Caution:

Do not use pliers or other gripping tools to hold Detent Pin (2-26). Raised burrs on Detent Pin (2-26) may cause pin to jamb depressed, resulting in an unsafe condition that could result in a fuel spill.

Remove Bolt (2-34) and Washers (2-35 & 36). From opposite end, remove Detent Pin (2-26) and Detent Spring (2-31) from Body (2-5).

Disassembly of the Coupler Subassembly (1-5) is completed.

9.5.4 61532A Carriage Assy

The Carriage Assy (1-W) should be removed from the unit before any work is performed on it.

Caution!

When operating the Carriage Assembly do not place hands onto any part of the unit except the Lever (6-10). Improper operation can result in injury to the hands.

Older units will utilize spacers that are loose from the Flange (6-9), either single piece or multi-piece, between the Flange (6-9) and the Body (2-5) to provide the correct spacing of the unit to the ground. This necessitates the use of longer fasteners, Screws (8-19), for the attachment of the unit to the coupler. Newer units will have the spacers pressed into the Flange (6-9) making it impossible to install them incorrectly. Screws (8-19) will also have provisions for lock wiring if desired. If option D is ordered these screws will be lock wired.

CAUTION!

Do not use the shorter Screws (2-2) on the four attachment points for the Carriage Assembly (1-W). The use of the shorter bolts can result in insufficient strength of the mating joint possibly resulting in an accident.

Remove Screws (8-19), Washers (or older one piece spacer) (8-18) (where present). Next remove Nuts (6-1), Washers (6-2) and Casters (6-3). Remove one Screw (6-4), Washer (6-5) and Washer (6-6). Set feet of Strut (6-16) into a soft jawed vise and hold securely. Grasp Spring (6-8) with a pair of vise grips or other suitable tool to hold it in place, pull the Shaft (6-7) from the Strut (6-16). Items (6-9) through (6-12) will then be loose. The other Washers (6-6) will also be loose. There is no need to remove the other Screw (6-4) and Washer (6-5) from the Shaft (6-8) unless one of the parts is to be disassembled. Remove Cotter (6-14) and Clevis (6-15) to disassemble Latch (6-13).

On newer units where the installation spacers are an integral part of the Flange (6-9) do not attempt to remove them, they are pressed in place.

10.0 Inspection And Repair

10.1 General

Inspect all metal parts for cracks, nicks, gouges, scratches, corrosion, etc. Special attention should be given to the Body (2-5) in the window areas that contain the Lugs (2-33). Weld repair in the area is not recommended due to potential distortion of the Body (2-5) which could cause the Collar (2-27) not to slide freely on the Body (2-5). Inspect all parts for stripped or crossed threads and loose inserts.

10.2 Collar Stop Assembly (1-G)

Inspect Torsion Spring (5-3) for distortion. Free ends of Spring (5-3) shall be in proper position and actuate Collar Stop (5-1) without evidence of sticking or binding. Inspect Collar Stop Assembly (1-G) for damage sufficient to prevent proper operation.

10.3 Coupler Subassembly (1-5)

Precisely measure the following wear surfaces. Discard and replace those parts that fail this inspection:

A. Pin (2-14) - Inspect bearing diameter for indications of galling, raised metal, etc. Replace pin if local wear results in low spots exceeding 0.005 inches (0.12 mm) below adjacent surfaces.

B. Link (2-16) - Place Link (2-16) on straight edge or surface plate and inspect for flatness. Replace Link (2-16) if bent. Measure longest dimensions of both holes in Link (2-16). Replace if longest dimension of the smaller hole exceeds 0.382

inch (9.70 mm) and larger hole exceeds 0.505 inch (12.83 mm).

C. Dust Cap (1-2) - Inspect for continued serviceability. Replace if required.

D. Bearing (2-13) - Measure outside diameter and inside diameter of Bearing (2-13). The outside diameter should not be less than 0.494 inch (12.55 mm) in the smallest dimension. The inside diameter should not be greater than 0.390 inch (9.91 mm) in the largest dimension. Replace Bearing (2-13) if either of these dimensions is exceeded.

Note:

This bearing was originally (for over 25 years) made of stainless steel. After evaluating complaints about its short life, the material was changed to a better bearing material, cast iron which has been dry-film lubricated. It is dark gray in color compared to a shiny stainless steel. This bearing will not perform its intended function if the Crank (2-20) is worn beyond the limits noted in the following paragraph. On a worn out crank, the bearing will become unsupported and crack quickly.

E. Crank (2-20) - Measure the diameter of the protrusion on the Crank (2-20) that mates with the Bearing (2-13). The diameter of the protrusion shall not be less than 0.365 inch (9.271 mm). Excessive wear of the protrusion will cause failure of the Bearing (2-13) as noted above. In addition, wear of the crank will increase the side load on the Poppet (2-15) or

Shaft (2-15E) which can result in catastrophic galling of the shaft and the shaft support in Body (2-5).

F. Poppet (2-15) or (2-15C) and Shaft (2-15 E) - Inspect sealing surface for nicks, scratches, or gouges that will cause leakage. Minor scratches may be repaired by polishing with abrasive cloth, 300 grid or finer. Measure Shaft (2-15E) through-hole largest diameter. Replace Poppet (2-15) or (2-15E) if through-hole largest diameter exceeds 0.382 inch (9.70 mm).

G. Lugs (2-33) - Measure diameter of hole through all 16 lugs. Reject all lugs with hole dimension greater than 0.163 inch (5.15 mm) in any direction. Use a new Lug (2-33) as a template. Compare each Lug (2-33) to the new Lug (2-33). Reject all lugs with local wear exceeding 0.030 inch (0.76 mm) by comparison to the new Lug (2-33). Carefully inspect all remaining Lugs (2-33) for cracks or other damage.

Caution:

Lug (2-33) failure can result in the coupler being ejected from the mating adapter. Replace any Lug (2-33) that is questionable.

H. Detent Pin (2-26) - Inspect diameter of end closest to Spring (2-31), annulus and 25° angle cam surface of pin for excess wear. Replace Detent Pin (2-26) with local wear in excess of 0.005 inch (0.125 mm) deep. Hint - It may be possible to prolong the life of the pin by rotating the pin such that any visible wear is not presented toward the Ball (2-30).

I. Lug Rings (2-32) - Inspect the four Lug Rings (2-32) for local wear. Replace rings where local wear has reduced local wire diameter below 0.149 inch (3.78 mm).

J. Ball Bearing (2-30) - Inspect Ball Bearing (2-30) for local wear or flat spots. Replace if any flat spots are observed.

K. Wave Washers (2-19 or 19A) - Carefully inspect the four Wave Washers (2-19) or the single (2-19A) for cracks. [Note: some units will have a two piece unit that has the same force as the single piece unit for the Wave Washer (2-19A)]. Replace cracked Wave Washers (2-19 or 19A). On some older models only three Wave Washers (2-19) were utilized. It is recommended to use four Wave Washers (2-19) or a single (2-19A). Check part to paragraph 5.5H, Figure B.

L. Collar (2-27) - Inspect the 0.335 inch (9.5 mm) wide shoulder, located on the collar's inside diameter 1.36 inches (35.5 mm) from the collar's connection end, for local depressions in excess of 0.08 inch (2.0 mm) wide and 0.010 inch (0.25 mm) deep. Replace Collar (2-27) if any are found. The inside diameter of the Collar (2-27) that rubs against the outer diameter of the Body (2-5) will also wear. The amount of allowable wear of both

parts together is checked by the use of the Wear Gauge, 61362. This allowable wear will be checked on a post assembly check using the Wear Gauge.

M. Body (2-5) - Inspect Body (2-5) for excessive wear, abrasions, gouges, cracks, etc. Pay particular attention to the area around the windows in which the Lugs (2-33) fit. If this area is cracked, replace the Body (2-5). Determine that the two pins shown in Figure 2 are in place. These pins are used to prevent rotation of the Lug Rings (2-32).

Caution:

If the pins are missing, rotation of the Lug Rings (2-32) will cause Lugs (3-33) to drop out and can cause a coupler disconnect.

The outer diameter of the Body (2-5) that rubs against the Collar (2-27) will also wear. The amount of allowable wear of both parts together is checked by the use of the Wear Gauge, 61362. This allowable wear will be checked on a post assembly check using the Wear Gauge.

N. Rigid Operating Handle (2-1) - Inspect the round surface of the Handle (2-1) and the adjacent surface of the Collar (2-27) that acts as the interlock for cracks, being bent, worn, etc. Replace damaged handle or Collar (2-27).

O. Folding Handle Assembly (1-B) - Inspect the round surface of the Handle Cam (1-10) and the adjacent surface of the Collar (2-27) that acts as the interlock for cracks, being bent, worn, etc. Replace damaged handle or Collar (2-27).

10.4 Female Half Quick Disconnect Assembly 1-K-N, P, R & S.

A. Balls (4-8) - Inspect the 24 Balls (4-8) for chips, flat spots, excess wear, etc. Replace as required.

B. Sleeve (4-6) - Inspect inside of Sleeve (4-6) for indications of brinelling or ball indentations at intersection of tapered surface with constant inside diameter at ball lock area as well as for cracks, excessive abrasions, or other damage. Replace if damaged or worn as described above. If carrying handle is worn such that it is no longer serviceable replace entire Sleeve (4-6). Measure the ball lock area which is the smallest inside diameter of the Sleeve (4-6). Replace Sleeve if smallest inside diameter is more than 5.415 inches (108.5 mm).

C. Housing (4-5) - Inspect Housing (4-5) for damage, abrasions, thread damage, cracks, etc. Inspect grooves on the outside of the Housing (4-5) for rounded edges. Replace Housing (4-5) if grooves are excessively worn such that they no longer safely retain rings.

D. Retainer Ring (4-7) - Place Retainer Ring (4-7) over Housing (4-5) so it is fully engaged in its groove (which is the groove closest to the ball

bearing holes). Press tips of the Ring (4-7) toward each other, but do not deform them. While pressing the tips, use a 6-inch vernier caliper, or equivalent, to measure the dimension from the outside of the one tip to the outside of the other tip. The dimension must be 3.90 inches (99.1 mm) minimum. If the dimension is less, the Retaining Ring (4-7) should be replaced.

E. Inspect Teflon Seal (4-9), if present (Options R and S only), for obvious damage, replace if needed.

10.5 Product Selection (Option C) (1-C)

Inspect the Coupler Subassembly (1-5) to assure the correct number of Product Selection Bolts (1-C) are utilized (five) and that they are placed in the correct positions. The outer head of the bolts should be flush to 0.03 inch (0.76 mm) below the adjacent Collar (2-27) surface.

10.6 Carriage Assy (1-W)

Inspect all parts, for cracks, especially in the Strut (6-16), Casters (6-3) for excessive wear that will make rolling difficult, and the contact surfaces of the Latch (6-13) and Lever (6-10).

Caution:

When operating the Carriage Assembly do not place hands onto any part of the unit except the Lever (6-10). Improper operation can result in injury to the hands.

Using a new Latch (6-13) as a guide, compare the contour of the new one to the one disassembled from the unit. If there is wear in excess of .030 (0.76 mm) it should be replaced.

Measure the distance on the Flange (6-9) between the centerline of the hole for the Shaft (6-7) to the surface that makes contact with the Latch (6-13). The dimension shall not exceed 1.04 (26.42 mm). The hole in the Flange (6-9) shall not be larger than 0.544 (13.818 mm).

Measure the Clevis Pin (6-15) diameter. It shall not be less than 0.370 (9.398 mm) in the area where the Latch (6-13) makes contact.

Measure the hole in the Latch (6-13). It shall not exceed 0.386 (9.804 mm).

Measure the diameter of the Shaft (6-7). It shall not be less than 0.485 (12.319 mm).

Check the four Screws (8-19) to be sure they are the correct length. They should have a shank length of 1 19/32 ± 1/32 inch. (40.5 mm). The other two bolts (2-2) will be 1 inch (25.4 mm) long. If the bolts are not the correct length, order kit 80898.

On newer units, units that do not utilize loose spacers [Washers (8-18) or single piece spacers, not shown] make sure that there are four spacers included as a part of Flange (6-9).

If there are no spacers present in the four mounting holes, then order kit 80898.

10.7 Pressure Control Elbow Assembly

Inspect all parts, especially sealing and seat surfaces, for scratches, nicks or gouges that can be causes for leakage or for operation problems. Clean all parts prior to reassembly. Check the Housing (3-23) for excessive external wear that could lead to structural failure of the unit. On all parts except Inner Piston (3-18) and Outer Piston (3-5), use 320 grit paper to smooth and remove sharp edges. The outer diameters of both the Inner Piston (3-18) and the Outer Piston (3-5) can be polished to remove minor scratches by using a very fine emery cloth while the parts are rotated. **Do not** polish local areas of these diameters. By using the Shaft (3-15) as a fixture, both pistons can be installed in a portable drill held in a vise to achieve rotation. **Do not** break through the hard anodize surface of the part. If scratches are too pronounced, the parts should be replaced. Replace any part with damage exceeding 15% of local wall thickness.

Nuts (3-1) are self locking types and their locking capability should be checked. Tighten them onto the Shaft (3-15) without the use of a wrench. The resistance to installation should make it impossible to install the nut fully onto the Shaft (3-15). If there is no resistance to installation, the Nuts (3-1) should not be reused.

Older units with serial numbers 1919 through 1923 and 1930 and greater will have a two piece adjustable Air Orifice (3-33A & 3-33B) or a Screw (33C) and Spring (33D) in lieu of the single Screw (3-33). Regardless of which, they should be removed for cleaning.

10.8 General Repair

A. Remove corrosion and minor damage from metal parts by polishing with abrasive cloth, 300 grid or finer. Apply chemical film (alodine 1200 or equivalent) to bared aluminum surfaces.

B. Cleaning – Clean all parts with clean solvent or fuel, using soft bristle brush and lint-free cloth. Air dry.

Warning:

Use solvent or fuel in safe, well ventilated area only.

10.9 Replacement

A. General – Replace all parts found damaged beyond repair or found excessively worn during inspections above.

B. Recommended Replacements – Eaton recommends that the following parts, if present, be replaced at each overhaul regardless of condition:

Item No.	Part No.	Description	Used On
1-8*	29179	Spring	Option B – Folding Handle Assy (1-B)
2-10	MS29513-249	O-ring	Coupler Assy (1-5)
2-11	202010	Cotter Pin	Coupler Assy (1-5)
2-15D	MS29513-037	O-ring	Coupler Assy (1-5)
2-17	28755	Nose Seal	Coupler Assy (1-5)
2-17	220428	Nose Seal	Option A only – Coupler Assy (1-5)
2-18	201201-347	O-ring	Coupler Assy (1-5)
2-18	MS29513-347	O-ring	Option A only – Coupler Assy (1-5)
2-21	200103	Bearing Washer	Coupler Assy (1-5)
2-22	203563	Bearing	Coupler Assy (1-5)
2-23	29221	Bearing	Coupler Assy (1-5)
2-25	MS29513-212	O-ring	Coupler Assy (1-5)
3-3	200754	Seal	Pressure Control Assy (1-1A, 1B or 1C)
3-4	MS29513-155	O-ring	Pressure Control Assy (1-1A, 1B or 1C)
3-9	203565	O-ring	Pressure Control Assy (1-1A, 1B or 1C)
3-10	200770	Seal	Pressure Control Assy (1-1A, 1B or 1C)
3-11	MS29513-149	O-ring	Pressure Control Assy (1-1A, 1B or 1C)
3-12	MS29513-240	O-ring	Pressure Control Assy (1-1A, 1B or 1C)
3-17	MS29513-012	O-ring	Pressure Control Assy (1-1A, 1B or 1C)
3-19	200758	Seal	Pressure Control Assy (1-1A, 1B or 1C)
3-20	MS29513-129	O-ring	Pressure Control Assy (1-1A, 1B or 1C)
3-21	MS29513-348	O-ring	Pressure Control Assy (1-1)
3-23C	MS29513-225	O-ring	Pressure Control Assy (1-1)
3-25	MS29513-009	O-ring	Pressure Control Assy (1-1A, 1B or 1C)
3-34	MS29513-008	O-ring	Pressure Control Assy (1-1A, 1B or 1C)
3-41	M83248/2-008	O-ring	Pressure Control Assy (1-1A, 1B or 1C)
3-42	MS29513-011	O-ring	Pressure Control Assy (1-1A, 1B or 1C)
4-9	AR10400-248AC	Seal	Option R & S Quick Disconnect

* Replace only if the Folding Handle Assy (1-B) has been disassembled.

10.10 Upgrading

- A. Closing Time Adjustable Orifice Kit - Use KD60700-1-6
- B. Lower Coupler Half High Strength Link - Use KD60700-1-2.

- C. Pressure Relief Shaft Assemble upgraded to present production unit - Use KD60700-1-4.
- D. Pressure Control Elbow Assembly to 42208-1 - Use KD60700-1-5.

11.0 Reassembly

11.1 General

Assembly is accomplished in essentially the reverse order of disassembly. The following paragraphs cover assembly of the major components, followed by final assembly of the complete Unit.

Replace Spring (1-8) each time the handle is disassembled. Assemble the Handle (1-B) as follows:

- A. Place the Cam (1-10) in small, soft-jawed vise.

11.2 Collar Stop Assembly (1-G)

- A. Insert Pin (5-4) through Bracket (5-2), Collar Stop (5-1) and Torsion Spring (5-3). Position free ends of the Torsion Spring (5-3) as shown in Figure 4.
- B. Install Cotter Pin (5-5).
- C. Check that the Collar Stop (5-1) moves under pressure of the Torsion Spring (5-3) without sticking or binding.

Caution:

Do not over tighten vise and collapse or damage handle Cam (1-10).

11.3 Folding Handle Assembly (Option B) (1-B)

- B. Position new Spring (1-8) in clevis of Handle (1-11) and place both between clevis of Handle Cam (1-10). Note the orientation of the flat and slotted end on the Pin (1-6) in Figure 1 to assure correct reassembly. Insert Pin (1-6) through holes in Handle Cam (1-10) and Handle (1-11) and with end of Spring (1-8) hole over Pin (1-6) and balance of Spring (1-8) passing under Pin (1-6) and over Handle (1-11).

C. Fasten end of Spring (1-8) to Pin with pan head Screw (1-9).

D. Insert large blade screwdriver in clevis end of Pin (1-6) and wind Spring (1-8) in a counterclockwise direction.

E. When Spring (1-8) is wound, insert Cotter Pin (1-7) to lock Pin (1-6). Operate Handle Assembly (1-B) to fully unfolded position while inspecting the following:

(1) Clearance between Spring (1-8) and adjacent face of Handle Cam (1-10) should occur throughout travel.

(2) Clevis ends of Handle (1-11) should bottom on face of Handle Cam (1-10) with Handle Assembly (1-B) in extreme extended condition.

11.4 Coupler Subassembly (1-5)

Replace all parts found defective in the inspections noted above with new or serviceable parts. Replace all parts specified in paragraph 10.8 with new parts. Lightly lubricate all O-rings and threaded parts with petroleum jelly (Vaseline or equivalent).

A. If a new Bumper (2-28) is being utilized it is suggested that the Bumper (2-28) be heated to 150° - 160° (32° - 71° C) to soften it to make assembly to the Collar (2-27) easier. This can be accomplished in either an oven or in hot water, however, use caution.

Caution:

Do not overheat Bumper (2-28) or it will melt!

B. Assemble four (4) Lugs (2-33) to each of four (4) Lug Rings (2-32). Assemble the four Lug Rings (2-32) with Lugs (2-33) installed in groove in Body (2-5) so Lugs (2-33) mate with slots in Body (2-5). The end of one Lug Ring (2-32) should be positioned against the spiral pin pressed into Body (2-5) (See Detail on Figure 2). This pin is there to prevent the Lug Rings (2-32) from gradually rotating around during use and allowing the Lugs (2-33) to become dislodged.

C. Slide Collar (2-27) (with Bumper (2-28) attached) over Body (2-5) from the outlet end, capturing Lug Rings (2-32) and Lugs (2-33). Install large Retaining Ring (2-29) into groove in Body (2-5).

D. Lay unit thus far assembled on its side with Detent Pin (2-26) hole in bottom location. Slide Collar (2-27) all the way forward against the Retaining Ring (2-29). Insert Ball Bearing (2-30) into Detent Pin (2-26) hole, making certain that it drops into the hole in the Body (2-5). Slide Collar (2-27) all the way back. Assemble Detent Spring (2-31) to Detent Pin (2-26). Place hardened rod of 5/32 inch (3.9 mm) or smaller diameter through hole at forward end of Detent Pin (2-26) and insert Detent Pin (2-26) and Spring (2-31) in hole in Body (2-5). Depress Detent Pin (2-26) as far as

possible and while holding Detent Pin (2-26) depressed, slide Collar (2-27) all the way forward. Holding the hardened rod through the Detent Pin (2-26) to prevent turning, assemble the Detent Pin (2-26) to the Body (2-5) by installing Washers (2-35 & 36) and Bolt (2-34). Washer (2-35), the one with the smallest outside diameter, should be adjacent to the head of the Bolt. Remove hardened rod after Bolt (2-34) is tightened.

E. Install Bearing (2-22) into crank shaft bore from inside of Body (2-5). Install Shaft Bearing (2-23) into crank shaft bore from outside of Body (2-5). Place Bearing Washer (2-21) over Crank Shaft (2-20) and insert Crank Shaft (2-20) through bearings.

F. Assemble one shaft seal Bearing (2-24), O-ring (2-25) and second shaft seal Bearing (2-24) over Crank Shaft (2-20) from the outside and press these parts into the Body (2-5), exerting care that the O-ring (2-25) is not pinched.

G. Position four (4) Wave Washers (2-19) or the single (2-19A) into Body (2-5) bore. Assemble O-ring (2-18) over Seal (2-17) and press into Body (2-5) bore, capturing Wave Washers (2-19 or 2-19A) and being careful that O-ring (2-18) is not pinched.

Note:

If multi-piece Poppet Assembly (2-15A) is used, check the tightness of the four Screws (2-15B) before proceeding. Torque for the Screws (2-15B) must be 10 ± 1 in. lbs. (11.5 ± 1 kg-cm). If the torque is less than specified, the screws have come loose in service and they should be replaced.

H. If Poppet (2-15A) was disassembled, reassemble at this time. Install O-ring (2-15D) into the groove in Shaft (2-15E) or (2-15G). Assemble Poppet (2-15C) onto part and retain with the four Screws (2-15B). Torque Screws to 10 ± 1 in.-lbs. (138 kg-cm) noting the running torque before tightening. If the running torque is under 6 in.-lbs. (6.9 kg.-cm.) replace Screws (2-15B) with new ones.

I. Insert Link (2-16) into Body (2-5) bore so Link (2-16) bump is in the bore's longest slot. Secure Poppet (2-15) to Link (2-16) with Pin (2-14) and press back into bore so Pin (2-14) is captured.

J. Slightly turn and work the largest hole in the Link (2-16) over lug of Crank Shaft (2-20). Place Bearing (2-13) through Link (2-16) and onto lug of Crank Shaft (2-20). Position Washer (2-12) over Bearing (2-13). Fasten Link (2-16) to Crank Shaft (2-20) with Cotter Pin (2-11).

Note:

The use of a standard headed cotter pin in lieu of the correct part number specified will present a problem when the Coupler Subassembly (1-5) is utilized as a part of Pressure Control Coupler 60700-1.

K. A post-assembly check using the Wear Gauge, 61362, is necessary to determine if the collective wear between the Collar (2-27) and Body (2-5) is less than allowable. Repeat the gauge check described in paragraph 9.4. It will be necessary to install the Woodruff Key (2-9) and the Handle (2-1 or 1-B) loosely to actuate the unit to the open position.

If the unit fails the gauge check, it will be necessary to disassemble the unit sufficiently to replace the Collar (2-27). If after the Collar (2-27) has been replaced and the unit still fails the gauge check, it will be necessary to replace the Body (2-5).

L. Install Woodruff Key (2-9) and Handle (2-1 or 1-B) onto Crank Shaft (2-20). Fasten Handle (2-1 or 1-B) with Washer (2-8), Lock Washer (2-7) and Bolt (2-6). Torque Bolt (2-6) to 90 ± 10 inch pounds (104 ± 12 kg-cm).

11.5 Pressure Control Elbow Assembly (1A, 1B or 1C)

11.5.1 Assembly

Replace all parts found defective in the inspection of paragraph 10.7 Replace all parts specified in paragraph 10.8 with new parts. Lightly lubricate all O-rings and threaded parts with petroleum jelly (Vaseline or equivalent). Refer to Figure 3A and proceed as follows:

A. Install Screen (3-35) and secure with Retaining Ring (3-36) in Housing (3-23).

On newer units that have the cartridge installation for Seals (3-19) and O-rings (3-20), including options R & S, proceed to the next paragraph B below. - Install two O-rings (3-20) and two inner piston Seals (3-19) into the appropriate grooves in Housing (3-23) so the Seals (3-19) shoulders are in accordance with the orientation shown in Figure 9. Installation of the seals in the manner previously called out in the older service manuals can lead to external leakage out of the vent port.

Note: The two inner piston Seals (3-19) are installed best if O-rings (3-20) are placed in the grooves first. Shape Seals (3-19) in a heart shape, folding between the index finger and the second finger. Work seal completely into groove.

B. On option R & S and on newer units of all other options [where the cartridge type seal installation for Seals (3-19) and O-rings (3-20) is utilized] O-rings (3-20) should be placed into the grooves in the Housing (3-23A). The Inner Piston Seals (3-19) will be installed with the inside diameter "leg" pointing away from the ambient

vent port. That is, the leg of each seal shall point toward each open end of the bore of the Housing (3-23A). Refer to Figure 9 for more detail. The "flange leg" of the Seal (3-19) must be inserted fully into the Housing (3-23A) groove. Smooth the combination of the Seal (3-19) and O-ring (3-20) with a finger to assure that they are installed completely into the groove.

C. It is recommended that seal "run-in" tool, AF42208-1, be used to condition the Seals (3-19) after installation. The tool can be procured through your Eaton Carter brand distributor. The tool can be used with a hand drill to accomplish the run-in task as follows:

(1). With the run-in tool attached to a hand drill, carefully insert the tool into the first Inner Piston Seal (3-19) and using a low speed, push the tool into the unit until the piston passes through the second Inner Piston Seal (3-19). The tool should be kept such that the piston portion of the tool makes contact only with the Seals (3-19) in the Housing (3-23) and does not make metal to metal contact .

(2). Carefully move the tool axially over a stroke of about 0.50 inch (12.7 mm) in and out maintaining contact with both Seals (3-19) for about one minute. The speed of the drill should be maintained at a low to medium RPM.

(3). Remove the tool .

D. Install O-rings (3-11, 3-12) in the appropriate Housing (3-23) grooves. Install O-ring (3-4) and outer piston Seal (3-3) in the groove on the inside of Housing (3-23) outlet so that the backup shoulder of the Seal (3-3) is on the outlet side of the groove.

E. Place Outer Piston (3-5) onto the appropriate end of Shaft (3-15). Hold loosely in place with Washer (3-2) and Nut (3-1). Use two thin 3/8-24-UNF-2B nuts as jam nuts at opposite end of Shaft (3-15) while torquing Nut (3-1) to 195 - 205 inch pounds (225 - 236 kg-cm). Remove the jam nuts.

F. Slide seat Retainer (3-8) onto the long end of Shaft (3-15). Install O-ring (3-9) and piston shaft Seal (3-10) into the bore in the Retainer (3-8) with the Seal (3-10) shoulder towards the inside of the Retainer (3-8). On newer Seal (3-10), the end opposite the flanged end will have a tapered end that is split. It is designed to be snapped into place for retention. Slide spring Guide (3-13) onto piston Shaft (3-15) with the shoulder of the Guide (3-13) toward the shaft's Outer Piston (3-5) end. Slide the Spring (3-14) over Guide (3-13). Place O-ring (3-17) into groove in the inside of the Inner Piston (3-18). Use sufficient petrolatum to hold the O-ring (3-17) in place during the final assembly. Place the Washer (3-16) on the free end of the Spring (3-14). Use the modified parallel bar wood worker's clamp described in NOTE

preceding step E in paragraph 9.3 to compress the assembly and hold it compressed.

CAUTION:

Be very careful to properly center the slots in the clamp tips and to adjust the two clamp screws evenly so the bars remain essentially parallel while compressing the spring. The piston Spring (3-14) force is between 50 and 55 lbs. when the Shaft (3-15) has entered Inner Piston (3-18) and the Inner Piston (3-18) is bottomed on Washer (3-16).

Install second Washer (3-2). Install second self locking Nut (3-1) and torque to 195 - 205 inch pounds (225 - 236 kg-cm) while holding the other self locking Nut (3-1) with an open end wrench to react the torque.

G. Remove the assembly from the clamp. Place four Washers (3-7) and Screws (3-6) in the piston seat Retainer (3-8).

H. Grasp this assembly by Outer Piston (3-5) struts and carefully insert into Housing (3-23) through the outlet until Outer Piston (3-5) has entered outer piston Seal (3-3) and the piston seat Retainer (3-8) has begun to enter the Housing (3-23) pilot diameter.

NOTE:

Inspect Retainer (3-8) to determine the location of the relief valve hole. Rotate the Retainer (3-8) if necessary so that the relief valve hole lines up with the relief valve hole in Housing (3-23) which is in the quadrant toward the Housing (3-23) inlet.

I. Tighten four Screws (3-6) and Washers (3-7) securing Retainer (3-8) to Housing (3-23). Torque to 19 ± 2 inch lbs. ($21.9 + 2$ kg-cm).

J. Verify that air orifice Screw (3-33, 3-33B or 3-33C) has been cleaned. On units using a fixed orifice Screw (3-33), install O-ring (3-34) onto Screw (3-33). Use a screwdriver to install air orifice Screw (3-33). On units using the adjustable Orifice Needle (3-34A) and Orifice Screw (3-33B) install Screw (3-33B) first using an Allen key, start the Screw (3-33B) into the treaded hole. Once started, turn the key clockwise 10 ± 1 revolutions. **Do not continue turning or the Screw (3-33B) may be lost inside of the unit.** With the key in the adjustment Orifice (3-33A) thread into the same hole. Gently torque the adjustment Needle (3-33A) clockwise until it bottoms against the Orifice Screw (3-33B) previously installed. **Do not torque down. Just bottom it out.** From the bottomed out position, loosen the Needle (3-33A) approximately one quarter ($\frac{1}{4}$) of a turn (counter-clockwise). An additional adjustment may be required at test.

On units with the Spring (3-33D) loaded Screw (3-33C) use and Allen key to tighten Screw (3-33C) to bottom out. Then back out Screw 3 - 4 complete turns. This should adjust closing time to approximately 2.5 to 3 seconds. Finer adjustment may be necessary during test.

Install Connector (3-32).

K. Assemble O-ring (3-25A) to Bleed Valve (3-30) and insert in Housing (3-23) fuel port so that Bleed Valve (3-30) button end passes through hole in Housing (3-23). Insert Springs (3-27, 3-29). Place Spring Guide (3-28) into Spring (3-29).

L. Assemble second O-ring (3-25B) to Check Valve (3-26). Place Check Valve (3-26) over Spring (3-27) and install Check Valve Housing (3-24) or (3-24B). If installing Check Valve Housing (3-24B) it is necessary to align the outlet such that it points in the proper direction to assure that the fuel sense hose will lay with its axis parallel to the centerline of the outlet. It may be necessary to use more than the recommended $1\frac{1}{2}$ wraps of Teflon tape on the pipe thread of the unit. If present, install Fitting (3-24A).

M. Place Spring (3-48) over Spring Slide (3-49). Compress Spring (3-48) with Washer (3-47) until slot in Slide (3-49) is visible above the Washer (3-47). Insert Shaft (3-46) into center hole of assembled parts until the hole in the Shaft (3-46) can be aligned with the slot in Slide (3-49). Insert Pin (3-50) through Slide (3-49) and Shaft (3-46) and release the Spring (3-48) to arrive at Shaft Assy (3-45). Assemble locking Nut (3-44) and O-ring (3-42) to pressure relief adjusting Screw (3-43). Slide Screw (3-43) over pressure relief Shaft Assembly (3-45). Assemble O-ring (3-41) to seal Retainer (3-40) and slide seal Retainer (3-40) over Shaft Assembly (3-45) until it bottoms on the shaft shoulder. Hold the pressure relief Shaft Assembly (3-45) in one hand and install Washer (3-39) and self-locking Nut (3-38). **Do not** tighten Nut (3-38) at this time.

N. Place Spring (3-47) over pilot of seal Retainer (3-40) and insert in the hole in the Housing (3-23) inlet. With the locking Nut (3-44) loose, tighten pressure relief adjusting Screw (3-43). Adjust the screw until the sum of a depth micrometer measurement from the head of the Shaft Assembly (3-45) to a parallel bar placed across the Housing (3-23) inlet plus the parallel bar thickness is 1.725 - 1.755 inches (43.8 - 44.6 mm). Then torque locking Nut (3-44) to 230 - 250 inch pounds (265 - 288 kg-cm).

Example: If parallel bar is measured and found to be exactly 0.500 inch (12.7 mm), then depth micrometer reading should be 1.225 - 1.255 inch (31.1 - 31.9 mm) when relief valve adjustment is within the required limits.

11.5.2

Preliminary Functional Test

True proof pressure, functional and leakage tests are conducted in conjunction with test of the complete automatic fuel pressure control coupler,

paragraph 12.0. It is well to conduct several tests at this stage of assembly however, before additional assembly labor is expended.

A. Hold the assembly in the hands and place the end of the pressure Relief Shaft Assembly (3-45) against a flat, sturdy surface. Press with enough force to compress the relief valve spring (opening the relief valve) and release (allowing the relief valve to close) several times. Then recheck the relief valve adjustment measurement as described in step N of paragraph 11.5.1. The relief valve adjustment should not change and the relief valve should not stick open.

B. Apply and relieve 60 psig air pressure at the Connector (3-32) several times. The Outer Piston (3-5) should open fully with each pressure application and fully close as pressure is relieved. There should be no indication of stickiness or hang-up in either direction.

C. Press Bleed Valve (3-30) button and release it several times to verify that it returns each time it is released.

11.6 Female Half Quick Disconnect (1-K-N, P, R & R)

Replace all parts found defective in the inspection procedures above.

A. Assemble the Retainer Ring (4-7) into Sleeve (4-6). Spread ends of the Retainer Ring (4-7) and slide both parts over Housing (4-5). Temporarily allow Retainer Ring (4-7) to seat in the Housing (4-5) groove nearest the pipe threaded end.

B. Set Housing (4-5) on end in a shallow container with the disconnect end up. Use a cotton-type swab to place a small amount of petroleum jelly on the bottom of each of the 24 holes in the Housing (4-5).

C. Carefully insert 24 Balls (4-8) into the holes in the Housing (4-5). The petroleum jelly should hold the balls in place while the ends of the Retainer Ring (4-7) are spread and the Sleeve (4-6) is moved to the engaged position, capturing the Balls (4-8).

D. Spread Lock Ring (4-1) and assemble into groove closest to threaded end on Housing (4-5).

E. On Options R & S lightly coat Seal (4-9) with petroleum jelly and install into groove in Housing (4-5) being sure that the open end of the "U" shaped part is pointing inward toward the threaded inlet of the Housing (4-5).

F. Keep Retainer (4-4) and Screws (4-3) handy for final assembly as noted later.

11.7 Carriage Assy (1-W)

Place the feet of the Strut (6-16) in a soft jawed vise to hold it firmly with the feet flat on the work bench. Install Latch (6-13), Clevis Pin (6-15), Washers (6-12) and Cotter Pin (6-14) into Strut (6-16). Install one Screw (6-4) and Washer (6-5) onto Shaft (6-7). Place two Washers (6-6) onto Shaft

(6-7) and then place Shaft (6-7) through one hole of the Flange (6-9) and Lever (6-10). Place another Washer (6-6) between the Lever (6-10) and Strut (6-16). Place this sub-assembly into position with the Strut (6-16) and the Spring (6-8). The straight tang of the Spring (6-8) is to be placed in the hole in the Strut (6-16).

Caution!

Be very careful during the next phase of the assembly. The Spring (6-8) is very strongly loaded and could cause injury if not controlled properly.

Grasp the Spring (6-8) with a pair of battery pliers (channel locks) with the straight tang toward the left. Using a pair of vise grips in the right hand grasp the spring and rotate the spring until the bent tang is approximately into position under the Flange (6-9). Holding the Spring (6-8) with the vise grips, push the Shaft (6-7) through the Spring (6-8) to engage the other hole of the Strut (6-16) and on through the other parts. Note that one Washer (6-6) should be placed between the Strut (6-16) and Lever (6-10) and between the Lever (6-10). Install two Washers (6-6) onto Shaft (6-7). Fasten in place with the other Screw (6-4) and Washer (6-5).

Install Spring (6-11) and Washer (6-12) into recess in Strut (6-16).

Final Caution!

If Carriage Assy (1-W) is latched when it is not attached to the unit, unlatching may cause serious injury. Be very careful in unlatching the Carriage Assy (1-W) in this position.

11.8 Final Assembly

Verify that the Coupler Subassembly (1-5), the Female Half Quick Disconnect (1-K-N & P), Elbow Assembly (1-1A, 1B or 1C) and the Collar Stop Assembly (1-G) have been overhauled and reassembled.

A. Assemble O-ring (2-10) onto the outlet of the Coupler (1-5).

B. Assemble Pressure Control Elbow Assembly (1-1A, 1B or 1C) to Coupler Assembly (1-5) while being careful that the O-ring (2-10) is not pinched. Fasten, along with Collar Stop Assembly (1-G), using six Screws (2-2), Washers (2-3) and tab of Dust Cap (1-2) beneath one Screw (2-2). Place Collar Stop Assembly (1-G) under two Screws (2-2) as shown in Figure 7. Lockwire Screws (2-2) is desired using Lockwire (4-2).

C. Install the Female Half Quick Disconnect (1-K-N, P, R or S) to the Male Half (part of the Elbow Assembly (1-1A, 1B or 1C)). Once in place, assemble the Retainer (4-4) in place with two Screws (4-3). For Options L or N (BSPP threads)

install a proper sized gasket (not furnished by Eaton) in the proper position. Use the wrench flats on the Female Half Housing (4-5) to tighten the unit to the hose.

D. If the Carriage Assy (1-W) is utilized, the four longer Bolts (8-19) must be used in lieu of the standard Bolts (2-2) for its installation. Check the four Screws (8-19) to be sure they are the correct length. They should have a shank length of $1\ 19/32 \pm 1/32$ inch. (40.5 mm). The other two bolts (2-2) will be 1 inch (25.4 mm) long. If the bolts are not the correct length, order kit 80898.

If the spacers between the Flange (6-9) and Body (2-5) are loose pieces (either a series of Washers (8-18) or single piece Spacers (not shown) then proceed with this paragraph. If the spacers are permanently affixed to the Flange (6-9), skip to the next paragraph. The Washers (8-18) will be used

as spacers between the Body (2-5) and Flange (6-9) except where the Collar Lock Assy (1-G) is used. In that case one of the Washers (8-18) will be replaced by the mounting bracket of the Collar Lock Assy (1-G). There will be seven Washers (8-18) used under three of the Screws (8-19) and six will be used where the Collar Lock Assy (1-G) is retained. Washers (2-3) will be utilized under the Screw (8-19) heads. See Figure 7. If Bolts (8-19) have provisions for lock wiring they may be lock wired using Lockwire (4-2).

When the spacers are affixed to the Flange (6-9), as on newer units, Washers (8-18) are used under the heads of Screws (8-19), with no other washers required.

Screws (2-2) and (7-19) should be torqued to 90 ± 10 in.-lbs. (104 ± 12 kg.-cm.).

12.0 Testing

12.1 Test Equipment

The following equipment is required:

Inlet test adapter conforming to API Bulletin 1584 with pressure equalization valve such as Eaton's Carter brand Model 60505D or 61526D.

- 0-300 psig fuel or test solvent pressure source.
- 0-125 psig air pressure source.
- Shutoff valves, regulators, pressure gauges, and other miscellaneous test equipment.

12.2 Test Conditions

Test media shall be Stoddard Solvent (Federal Specification P-D-680), JP-4 per Mil-J-5624, Jet A or equivalent.

12.3 Functional Test

A. With the Collar (2-27) retracted (unit not attached to an adapter and closed), verify that the opening Handle (1-B or 2-1) cannot be rotated to the open position.

B. Depress and release the Detent Pin (2-26) several times to verify that the pin promptly extends and locks the Collar (2-27) each time it is released. Rotate the Detent Pin (2-26) in 90° increments and repeat this operation at each position to verify that there is no position at which the Detent Pin (2-26) hangs retracted.

C. With the Collar (2-27) retracted, place the Coupler squarely over an unpressurized, vented Eaton Carter brand Model 60505D or 61526D Adapter so the face of the adapter depresses the Detent Pin (2-26). The Collar (2-27) should drop freely in a positive manner into the engaged position with no hesitation, sticking or binding. With the Collar (2-27) extended, it

should be impossible to separate the unit from the test adapter. Retract the Collar (2-27), depressing the Collar Lock Assembly (1-G), if present, at the same time, and lift the unit off of the adapter. The Detent Pin (2-26) should extend and prevent extension of the Collar (2-27).

D. Repeat C several times. Then, engage the unit to the adapter and open and close the Poppet (2-15) by rotating the operating Handle (2-1 or 1-B), while verifying that it is not possible to retract the Collar (2-27) with the Handle (2-1 or 1-B) in any position but the fully closed position. The Collar Stop Assembly (1-G), if present, should automatically engage the Collar (2-27) each time the Collar (2-27) becomes extended preventing the retraction of the Collar (2-27) until it is manually depressed.

E. Repeat D several times. Then, retract the Collar (2-27) and separate the Unit from the adapter. Verify that the Detent Pin (2-26) has extended and locked the Collar (2-27) in the retracted position. Verify that the Poppet (2-15) can not be opened with the Collar (2-27) retracted.

12.4 Proof and Leakage Test – Detached

A. With the unit not attached to an adapter, apply 5 psig fluid pressure to the outlet of the Unit and 60 psig air pressure to the deadman air connection and maintain for one minute. Observe the unit for external and/or seal leakage, then relieve the applied pressures.

When the spacers are affixed to the Flange (6-9), as on newer units, Washers (8-18) are used under the heads of Screws (8-19), with no other washers required.

Screws (2-2) and (7-19) should be torqued to 90 ± 10 in.-lbs. (104 ± 12 kg.-cm.).

12.5 Proof and Leakage Test - Engaged

- A. Connect the unit to a test adapter with an available fluid pressure source of 0-300 psig. The test adapter shall have a manually controlled shutoff valve attached to its inlet. Connect a 0-125 psig air pressure source to the unit's deadman connection.
- B. Open the unit's Poppet (2-15) using Handle (2-1 or 1-B).
- C. Apply 60 psig air pressure to the deadman connection.
- D. Fill the test unit and adapter with liquid while bleeding all air through the valve at the adapter inlet. (Rotate the test setup so the adapter and its valve are at the high point while bleeding air.)
- E. With the test setup full and bled, close the shutoff valve. Then increase the test fluid pressure to 300 psig and maintain for one minute while inspecting the Unit for indications of external leakage.
- F. Reduce the test pressure to 5 psig and repeat step E.
- G. There shall be no indication of external leakage, permanent deformation or set during or after the above test.
- H. Reduce the test pressures to 0 psi. Close the Poppet (2-15) and disengage the unit from the test adapter.

12.6 Internal Leakage and Functional Test

- A. Connect the test fluid pressure source to the test adapter inlet. Connect the test unit to the adapter and open the Poppet (2-15). Remove the unit's outlet test adapter and place the unit such that its outlet is in an upward position. Connect the 0-125 psig air source to the unit's deadman connection through a three-way valve.
- B. Squeeze and release the deadman air valve several times, applying and venting 60 psig air pressure, while observing the movement of the Outer Piston (3-5). The Outer Piston (3-5) shall fully open with each application of air and fully close each time the air is vented.
- C. With the air pressure applied, fill the test unit with test fluid to a level above the Outer Piston Seal (3-3) and release the air pressure to close the Outer Piston (3-5). Drain the liquid from the unit's outlet and increase the internal liquid pressure to 5 psig. Rotate the unit such that any leakage from the unit can be collected in a beaker or other suitable measuring device and measure liquid leakage at the outlet for one minute. On a factory new unit the leakage allowable from the Unit is 10 cc/min. An

overhauled unit may have a leakage rate of up to 30 cc/min.

12.7 Relief Valve Function

- A. Using the same setup as above, deadman air relieved, test unit filled and bled, place a shop rag or equivalent over the outlet to restrain relief valve flow.

Caution:

Wear safety glasses or other eye protection during this test to prevent possible eye injury from test liquid exposure.

- B. Apply 150 psig liquid pressure through the inlet test adapter. Then close the coupler poppet and apply a steady force in the closed direction while verifying that the coupler poppet shaft has opened the relief valve venting trapped liquid downstream of the unit's piston seat (through the hole in the seal retainer) to allow coupler poppet closure.

- C. Then disengage from the test adapter, open the unit with deadman air pressure and drain all test liquid through the outlet.

12.8 Flow Testing

12.8.1 Installation

The unit should be installed in a test system equivalent to that shown in Figure B, with the air and fuel sense lines connected. Bleed the fuel sense line through the unit's bleed valve. Be sure the female half quick disconnect is connected. The hydrant deadhead pressure shall be initially set at 120 psig.

12.8.2 Coupler

Start the pump with the coupler poppet in the fully closed position. Slowly open the poppet by rotating the poppet operating handle counter-clockwise. Some resistance will normally be felt when the handle has been rotated about 45 degrees. At this point, maintain some pressure against the poppet to allow the pressure equalizer valve (in the inlet test adapter) to fill and pressurize the unit. When the pressure has equalized, open the poppet fully. Check that the poppet opens fully without the handle striking the coupler collar which might prevent full over-center operation. Next close the poppet to check for proper relief valve operation within the automatic fuel pressure control valve. Resistance to closing at about the 45 degree position (from fully closed) is normal. However, when constant pressure is held against the handle, the relief valve should bleed fluid (internally) from the unit which will allow the handle to slowly close fully. Lift the collar and disconnect the coupler.

12.8.3 Fuel Sense Bleed

Before operating the unit, it is very important that the following bleed operation be performed.

Close both nozzle poppets in the flow system. Apply deadman air pressure to open the unit. Since the coupler poppets are still closed, there will be no flow or pressure change. Next open the coupler poppet part way to allow fuel flow through the pressure equalizer valve. Allow the system pressure to build to approximately 20 psig then close the coupler poppet and release the deadman air pressure. Cover the Bleed Valve (3-30) with a rag and open with the blade of a screwdriver to obtain a steady bleed flow. Allow the line to bleed until all signs of air are eliminated. Release Bleed Valve (3-30). Open nozzle poppets and the coupler poppet.

12.8.4 Pressure Control Testing

A. With the system valves open sufficiently to obtain approximately 1000 gpm or maximum system flow rate, apply 75 psig deadman air pressure. The regulator should open and assume a pressure regulation. The fuel pressure regulation should be roughly 25 psig less than the deadman air pressure. This is commonly referred to as bias pressure.

B. While flowing at 1000 gpm or maximum system flow rate, whichever is the lower, release the deadman air valve and measure the time required to reach zero flow. The time required should be between 2-5 seconds. Factory setting of a new coupler for closing time is $3 \pm .5$.

Overshoot, the volume of fuel passing through the unit during closure shall not exceed 30 gallons at the 1000 gpm flow rate. If the overshoot exceeds the allowable amount, the closing time can be readjusted by turning Screw (3-33C) or Needle (33B) counter-clockwise to increase the orifice size. On older units there is no adjustment and the opening time will be set at about 4 seconds.

Also measure the time required to open from zero flow to 900 gpm or maximum system flow rate, whichever is the lower. The new units are set to open at approximate seven seconds, however, the specification allows opening times of from 5-10 seconds. This is not adjustable, but is slightly affected by the closing time adjustment on the newer units. On the older units opening time should be about 5 seconds. The operating time will vary with system setup and adjustments but should be within the same range of times from unit to unit.

C. Throttle the system flow from 1000 gpm flow to 0 flow in about 5 increments to stabilize at each flow rate. The stabilized pressure at the venturi should be 50 psig or less except it may be higher at shutoff if the flow is shutoff very rapidly. The regulated fuel pressure should be stable at all flow rates.

D. Close the nozzle poppets and apply deadman air to open the regulator against a locked out system. The locked in pressure should not exceed 75 psig and most units will lock in about 63-68 psig.

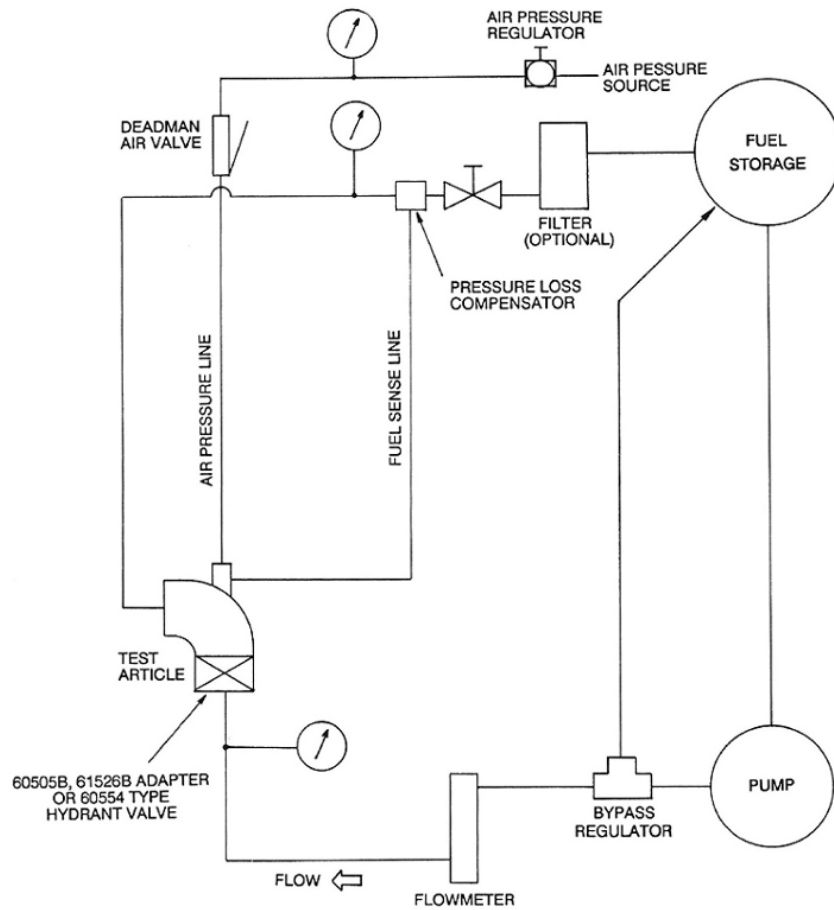

FIGURE C
SIMPLIFIED TEST SYSTEM SCHEMATIC DIAGRAM

12.8.5 Dynamic Closing Leakage

With the deadman valve released and the nozzle poppets open, set the hydrant pressure to 150 psig.

Squeeze the deadman and open flow to 600 USgpm or more. Release the deadman. The pressure control valve shall close and prevent leakage greater than 30 cc/min. Within 30

seconds of closing there shall be no audible squeal or buzz from the unit.

12.9 Post Test Procedure

After removing unit from test system place on an adapter housing and open poppet to drain fuel.

13.0 Storage

If it is necessary to store the unit for any length of time, install the dust cap, if present, otherwise cover the inlet and outlet with a moisture barrier

paper or film to protect it from the effects of dust and high humidity.

14.0 Illustrated Parts Catalog

Tables 1.0 through 6.0 tabulate the parts and sub-assemblies comprising the 60700-1 Model Hydrant Pressure Control Coupler including all available

options. The item numbers of the table are keyed to the exploded views shown in Figures 1 through 6.

TABLE 1.0
60700-1 Coupler and Options

Fig.	Item	Part Number	Description	Units / Assy	Coupler Option	Spares/10 Units/Yr
1	1A	42208-1	Pressure Control Elbow Assy (O-ring).....	1	Older units	-
	1B	42208-3	Pressure Control Elbow Assy (Teflon Seal)	1	R & S	-
	1C	42208-1	Pressure Control Elbow Assy (Cartridge Seals)	1	Newer units	-
	2	44660	Exterior Dust Cap.....	1	All	-
	3-4	Left blank intentionally				
	5	61525	Lower Half Coupler Assy	1	All	-
	B	41731	Folding Handle Assy.....	1	B	-
	6	29178	Pin.....	1	B	-
	7	GF9245-68	Cotter Pin.....	1	B	4
	8	29179	Spring.....	1	B	10
	9	GF51957-42	Screw.....	1	B	2
	10	29177	Handle Cam.....	1	B	1
	11	207355	Handle.....	1	B	-
	C	GF4-7A	Product Selection.....	5	C	-
	G	44140	Collar Stop Assy	1	G	-
	K	41730-3	Female Half, 3" NPT.....	1	K	-
	L	41730-4	Female Half, 3" BSPP	1	L	-
	M	41730-1	Female Half, 4" NPT.....	1	M	-
	N	41730-2	Female Half, 4" BSPP	1	N	-
	P	60740	Female Half, 4" ASSPT	1	P	-
	R	47087-3	Female Half, 3" NPT (Omni seal).....	1	R	-
	S	47087-1	Female Half, 4" NPT (Omni seal).....	1	S	-
	W	60532A	Carriage Assy	1	W	-
	X	47073	Handle Assy.....	1	X	-
-		KD60700-1-1	Kit - Contains all soft goods (seals) and other necessary parts to overhaul a 60700-1 Coupler that utilizes obsolete Lower Half Couplers 42221 and 42221-1 with either Pressure Control Elbow Assy 42208 or 42208-1. Contains items - 2-10, 2-13, 2-17, 2-18, 2-21, 2-22, 2-23, 2-25, 2-28, 2-32, 2-33, 3-3, 3-4, 3-6, 3-9, 3-10, 3-11, 3-12, 3-17, 3-19, 3-20, 3-21, 3-25A, 3-25B, 3-34, 3-38, 3-41, 3-42 & 207521 Pin.			
-		KD60700-1-2	Kit - Contains all parts from the KD60700-1 (except the special cotter key used in the 42221) plus the parts needed to upgrade the Lower Coupler Half to the higher strength 44665 (61525). Contains items - 2-28, 2-32, 2-33, 3-3, 3-4, 3-6, 3-9, 3-10, 3-11, 3-12, 3-17, 3-19, 3-20, 3-21, 3-25A, 3-25B, 3-34, 3-38, 3-41, 3-42 & KD44665-1 Upgrade Kit.			
-		KD60700-1-3	Kit - Contains all soft goods (seals) and other necessary parts to overhaul a 60700-1 Coupler that utilizes the newer 44665 (61525) Lower Coupler Half. Contains items - 2-10, 2-11, 2-12, 2-13, 2-17, 2-18, 2-21, 2-22, 2-23, 2-25, 2-28, 2-32, 2-33, 3-3, 3-4, 3-6, 3-9, 3-10, 3-11, 3-12, 3-17, 3-19, 3-20, 3-21, 3-25A, 3-25B, 3-34, 3-38, 3-41 & 3-42.			
-		KD60700-1-4	Kit - Contains all parts from the KD60700-2 plus the parts needed to upgrade the pressure relief shaft assembly to the latest production configuration. Contains items - 2-28, 2-32, 2-33, 3-3, 3-4, 3-6, 3-9, 3-10, 3-11, 3-12, 3-17, 3-19, 3-20, 3-21, 3-25A, 3-25B, 3-34, 3-38, 3-41, 3-42 & KD44665-1 & KD200751-1 Upgrade Kits.			
-		KD60700-1-5	Kit - Contains the same as the KD60700-4 plus parts needed to upgrade the 42208 Pressure Control Elbow Assy to the 42208-1. Contains items - 2-28, 2-32, 2-33, 3-3, 3-4, 3-6, 3-9, 3-10, 3-11, 3-12, 3-17, 3-19, 3-20, 3-21, 3-25A, 3-25B, 3-34, 3-38, 3-41, 3-42 & KD44665-1, KD200751-1 & KD42208 Upgrade Kits.			
-		KD60700-1-6	Kit - Adjustable Closing Time Orifice Conversion Kit - Contains items 3-33A, 3-33B and 220023 Hex Key or later kits contain items 3-33C and 3-33D.			
-		KD60700-1-7	Kit - Parts to overhaul the 42208-1 Pressure Control Elbow - Contains items 3-3, 3-4, 3-9, 3-10, 3-11, 3-12, 3-17, 3-19, 3-20, 3-25A, 3-25B, 3-34, 3-41 & 3-42.			
-		KD60700-1-8	Kit - Parts to convert 60600 Coupler to 60700-1 Coupler using existing Female Quick Disconnect Assembly. - Contains items 1-1B, 2-10, & 4-6.			
-		KD60700-1-9	Kit - Contains all soft goods (seals) and other necessary parts to overhaul a 60700-1 Coupler that utilizes obsolete Lower Half Couplers 42221 and 42221-1 with either Pressure Control Elbow Assy 42208 or 42208-1. Same as KD60700-1-1 except for -65°F service. Contains items (lower temperature versions of) 2-10, 2-13, 2-17, 2-18, 2-19A, 2-21, 2-22, 2-23, 2-25, 2-28, 2-32, 2-33, 3-3, 3-4, 3-6, 3-9, 3-10, 3-11, 3-12, 3-17, 3-19, 3-20, 3-21, 3-25A, 3-25B, 3-34, 3-38, 3-41, 3-42 & 207521 Pin.			

- KD60700-1-10 For overhaul of the 60700-1 with the 44665 lower half.
- KD60700-1-11 For overhaul of 60700-1 couplers utilizing lower halves 42221 and 42221-1 with 42208-1 pressure control elbows with inner piston seal cartridge.
- KD60700-1-12 Upgrade kit to replace old style piston shaft seal for 4" couplers P/N 60700 and 64702.
- KD60700-1-13 Upgrade kit to replace old style piston shaft seal for 4" couplers P/N 60704.
- KD60700-1-14 Provides studs and nuts kit for elbow and coupler halves assembly.
- KD60700-1-15 Upgrade coupler seal cartridge assembly.
- KD60700-1-16 Upgrade coupler relief valve assembly.
- KD60700-1-17 Upgrade coupler lower half latching lugs in compliance to breadaway force per API/IP specification 1584, 3rd edition.
- KD60700-1-18 Upgrade coupler lower half latching lugs in compliance to breadaway force per API/IP specification 1584, 3rd edition and strengthened actuating collar.
- KD60700-1-19 Provides the O-ring energized inner piston seals needed to overhaul the 42208 or 42208-1 (of Rev. N or older) pressure control elbow without inner piston seal cartridge.
- KD60700-1-20 Coupler lower half latching lugs in compliance to breadaway force per API/IP specification 1584, 2nd edition.
- KD60700-1-21 Coupler lower half latching lugs in compliance to breadaway force per API/IP specification 1584, 2nd edition and strengthened actuating collar.

TABLE 2.0
61525 Lower Coupler Half

Fig.	Item	Part Number	Description	Units/ Assy	Coupler Option	Spares/10 Units/Yr
2	1	207494	Handle.....	1	All but B	2
	2-36	44665	Coupler, Lower Half	1	All but A	-
	2-36	47113	Coupler, Lower Half (low temp.)	1	A	-
	2	GF24673-16	Screw	6	All	-
	3	GF960C516	Washer.....	6	All	-
	4	Left intentionally blank				
	5	43945	Body.....	1	All	-
	6	GF4-4A	Bolt.....	1	All	-
	7	GF35338-44	Lockwasher.....	1	All	-
	8	28781	Washer.....	1	All	-
	9	201286	Key.....	1	All	-
	10	MS29513-249	O-ring	1	All	10
	11	202010	Cotter Pin.....	1	All	2
	12	NAS1169C10	Washer.....	1	All	-
	13	28765	Bearing.....	1	All	5
	14	210004	Pin.....	1	All	1
	15	209600	Poppet.....	1	All	1
	15A	47064-1	Poppet Assembly	1	All	1
	15B	LP57G82P8	Screw	4	All	1
	15C	220276	Poppet.....	1	All	1
	15D	MS29513-037	O-ring	1	All	-
	15E	220275	Shaft.....	1	All	1
	16	209601	Link	1	All	1
	17	28755	Seal, Nose	1	All but A	10
		220428	Seal, Nose (Low Temp.)	1	A	10
	18	201201-347	O-ring	1	All but A	10
		MS29513-347	O-ring	1	A	10
	19	29232	Wave Washer	4	All	-
	19A	210587	Wave Washer	1	All	-
	20	209996	Crank Shaft.....	1	All	-
	21	200103	Washer.....	1	All	2
	22	203563	Bearing.....	1	All	10
	23	29221	Bearing.....	1	All	10
	24	29216	Bearing.....	2	All	10
	25	MS29513-212	O-ring	1	All	10
	26	200689	Detent Pin	1	All	-
	27	207482	Collar.....	1	All	1
	28	28928	Bumper	1	All	1
	29	RR-800-S	Retaining Ring	1	All	-
	30	GF19060-4815	Ball	1	All	-
	31	28763	Spring.....	1	All	-
	32	28760	Lug Ring.....	4	All	4
	33	200688	Lug.....	16	All	32
	34	GF3-3A	Bolt.....	1	All	-
	35	GF960C10L	Washer.....	1	All	-
	36	GF35333-39	Lockwasher.....	1	All	-

TABLE 3.0

Pressure Control Elbow Assy

Fig.	Item	Part Number	Description	Units/ Assy	Coupler Option	Spares/10 Units/Yr
1	1A	42208-1	Pressure Control Elbow Assy (Serial number 2399 & lower).			
	1B	42208-3	Pressure Control Elbow Assy (Teflon QD seal version only).			
	1C	42208-1	Pressure Control Elbow Assy (Serial number 2400 & subsequent).			
	1D	42208-4	Pressure Control Elbow Assy (Lower Temperature Capability).			
3	1	50FK-624	Nut.....	2	All	-
	2	GF960C616L	Washer.....	2	All	-
	3	200754	Seal, Outer Piston.....	1	All	10
	4	MS29513-155	O-ring.....	1	All	10
	5	202334	Piston, Outer.....	1	All	3
	6	LP51958-64	Screw.....	4	All	2
	7	NAS620C10L	Washer.....	4	All	-
	8	200756	Retainer, Piston Seat.....	1	All	-
	9	203565	O-ring.....	1	All	10
	10	200770	Seal, Piston Shaft.....	1	All	-
	11	MS29513-149	O-ring.....	1	All	10
	12	MS29513-240	O-ring.....	1	All	10
	13	200879	Guide, Spring.....	1	All	-
	14	200757	Spring, Piston.....	1	All	-
	15	202290	Shaft, Piston.....	1	All	-
	16	202291	Washer.....	1	All	-
	17	201201-012	O-ring.....	1	All	10
	18	200759	Piston, Inner.....	1	All	3
	19	200758	Seal, Inner Piston.....	2	All	20
	20	MS29513-129	O-ring.....	2	All	10
	21	201201-348	O-ring.....	1	All A, R, S, T	10
		MS29513-348	O-ring.....	1	A	10
	22	28382	Ring, Ball Race.....	2	All	2
	23	42210-1	Housing Assy (Note 5 & 6).....	1	Note 5	-
		47088	Housing Assy (Note 5 & 6).....	1	R, S, T	-
		42210-2	Housing Assy (Note 5 & 6).....	1	s.n. 2400 & subs	-
	23A	221307	Housing (Note 6).....	1	All	-
	23B	GF16997-32L	Screw (Note 6).....	4	All	-
	23C	MS29513-134	O-ring (Note 6).....	2	All	-
	24	200850	Housing, Check Valve (Note 3).....	1	All	-
	24A	PL120-3/83/8JIC	Fitting (Note 3).....	1	All	-
	24B	220293	Housing, Check Valve (Note 3).....	1	All	-
	25A	MS29513-009	O-ring.....	1	All	20
	25B	MS29513-008	O-ring.....	1	All	20
	26	200788	Valve, Check.....	1	All	-
	27	200791	Spring, Check Valve.....	1	All	-
	28	201914	Guide, Spring.....	1	All	-
29	200790	Spring, Bleed Valve.....	1	All	-	
30	200787	Valve, Bleed.....	1	All	-	
31	Left intentionally blank					
32	29736	Connector.....	1	All	-	
33	201002	Screw, Air Orifice.....	1	Older units	-	
33A	220017	Needle, Orifice (Adjustable).....	1	All	-	
33B	220018	Screw, Orifice (Adjustable).....	1	All	-	
33C	220413	Screw, Orifice (Adjustable).....	1	All	-	
33D	220472	Spring.....	1	All	-	
34	MS29513-008	O-ring.....	1	Older units	10	
35	7-1F60	Screen.....	1	All	-	
36	N5000-43-H	Ring, Retaining.....	1	All	-	
37	29436	Spring, Relief Valve.....	1	All	-	

Fig.	Item	Part Number	Description	Units/ / Assy	Coupler Option	Spares/10 Units/Yr	
3	38	GF21083C04	Nut.....	1	All	-	
	39	NAS620C4	Washer.....	1	All	-	
	40	29555	Retainer, Seal.....	1	All	2	
	41	M83248/2-008	O-ring	1	All	10	
	42	MS29513-011	O-ring	1	All	10	
	43	200752	Screw, Pressure Relief Adjusting	1	All	-	
	44	200761	Nut.....	1	All	-	
	45	44229	Shaft Assy, Pressure Relief.....	1	AA	-	
	46	221605	Shaft, Pressure Relief.....	1	All	-	
	47	5710-83-32	Washer.....	1	All	-	
	48	207519	Spring, Override, Relief	1	All	-	
	49	221606	Slide	1	All	-	
	50	GF16562-194	Spring Pin.....	1	All	-	
	-	-	KD42208-1	Kit consisting of the 42210-2 Housing and all internal seals and mating seals installed ready for final assembly. - Contains items 2-10, 3-3, 3-4, 3-9, 3-10, 3-11, 3-12, 3-19, 3-20, 3-21, 3-23, 3-23A, 3-23B, 3-23C, 3-33C & 3-33D. (Note 5)			
	-	-	KD42210-2	Kit consisting of the 42210-2 Housing and all internal seals and mating seals installed ready for final assembly. - Contains items 2-10, 3-3, 3-4, 3-9, 3-10, 3-11, 3-12, 3-19, 3-20, 3-23, 3-23A, 3-23B, 3-23C, 3-33C & 3-33D. (Note 5)			

TABLE 4.0

Quick Disconnect Female Half

Fig.	Item	Part Number	Description	Units/ / Assy	Coupler Option	Spares/10 Units/Yr
1	K	41730-3	Female Half, 3" NPT	1	K	-
	L	41730-4	Female Half, 3" BSPP	1	L	-
	M	41730-1	Female Half, 4" NPT	1	M	-
	N	41730-2	Female Half, 4" BSPP.....	1	N	-
	P	60740	Female Half, 4" ASSPT.....	1	P	-
	R	47087-3	Female Half, 3" NPT.....	1	R	-
	S	47087-1	Female Half, 4" NPT.....	1	S	-
4	1	26961	Lock Ring	1	K-N,P,R,S	-
	2	GF20995C32	Lock Wire	A/R	D,K-N,P,R,S	1 Spool
	3	GF35276-261	Screw	2	K-N,P,R,S	3
	4	28383	Retainer.....	1	K-N,P,R,S	1
	5	29173	Housing, 4" NPT.....	1	M	-
		29174	Housing, 4" BSPP	1	N	-
		27374	Housing, 3" NPT.....	1	K	-
		27377	Housing, 3" BSPP	1	L	-
		201742	Housing, 4" ASSPT	1	P	-
		207253-1	Housing, 3" NPT.....	1	S	-
	307253-3	Housing, 4" NPT	1	R	-	
	6	28779	Sleeve	1	K-N,P,R,S	-
7	26962	Retainer Ring	1	K-N,P,R,S	-	
8	GF19060-4818	Ball	24	K-N,P,R,S	-	
9	220552	Seal	1	R, S	10	

TABLE 5.0

Collar Stop Assy, Option G

Fig.	Item	Part Number	Description	Units/ / Assy	Coupler Option	Spares/10 Units/Yr
1	G	44140	Collar Stop Assy.....	1	G	-
5	1	207165	Stop	1	G	-
	2	207166	Bracket	1	G	-
	3	207167	Spring.....	1	G	1
	4	GF20392-2C63	Pin	1	G	-

5 GF24665-151 Cotter Pin 1 G 2

TABLE 6.0
60532A Carriage Assy, Option W

Figure	Item	Part Number	Description	Units Per Assembly	Coupler Option	Spares/10 Units/Yr
1	W	60532A	Carriage Assy.....	1	W	-
6	1	GF51971-4	Nut.....	2	W	-
	2	GF35338-47	Washer.....	2	W	-
	3	203577	Caster.....	2	W	-
	4	GF35206-296	Screw.....	2	W	-
	5	GF35333-41	Washer.....	2	W	-
	6	GF960-816L	Washer.....	6	W	-
	7	29745	Shaft.....	1	W	-
	8	29663	Spring, Torsion.....	1	W	-
	9	29664	Flange, obsolete, (Note 4).....	1	W	-
		47078	Flange, with spacers (Note 4).....	1	W	-
	10	201041	Lever.....	1	W	-
	11	29665	Spring.....	1	W	-
	12	GF960-616L	Washer.....	3	W	-
	13	29662	Latch.....	1	W	2
	14	GF9245-44	Cotter.....	1	W	-
	15	GF20392-5C73	Pin, Clevis.....	1	W	-
	16	29667	Strut.....	1	W	-
8	17	80898	Hardware Kit (Note 4).....	1	W	-
	18	GF960C516	Washer.....	28	W	-
	19	GF5-14A	Bolt.....	4	W	-
17A	47080	Hardware Kit (Note 4).....	1	W	-	
18	GF960C516	Washer.....	4	W	-	
19	GF5H-14A	Screw.....	4	W	-	

- Notes:
1. All part numbers beginning with "GF" are interchangeable with those beginning with either "AN" or "MS". If the "GF" is followed by three numbers it is interchangeable with an "AN" part, otherwise it is interchangeable with an "MS" part of the same number.
 2. The recommended spare parts shown above are the number required to support 10 Units for one year. In addition it is advisable to keep a spare Coupler Subassembly (1-5) complete with the Elbow Assy (1-E or F) to interchange with any unit in the field that may exhibit a problem. The recommended quantities are based on the ratio of spare parts sold for each unit during a one year period of time. The actual quantity required will vary from location to location.
 3. If Housing (3-24) is present, Fitting (3-24A) and Housing (3-24B) will not be there. Fitting (3-24A) and Housing (3-24B) replaced Housing (3-24) in later production units and can be used to better align the fuel sense hose on the unit.
 4. Item 17, 80898, is an installation kit used with Flange (6-9), 29664, that does not have integrally fitted installation spacers. Item 17A, 47080, is an installation kit used with Flange (6-9), 47078, that has the fitted installation spacers. When ordering a new Flange (6-9) order part number 47078.
 5. Item 3-23, Housing, 42210-1, used on units with serial numbers 2399 or lower, has integral O-ring grooves for Seals (3-19) & O-ring (3-20) and in newer units, serial numbers 2400 and greater, (including options A, R, S & T) has been replaced by the appropriate Housing (3-23) with a removable cartridge [Housing (3-23A)] to facilitate the replacement of the seals and O-rings. Neither 42210-1, 47088 nor 42210-2 are procurable as spare parts. Instead Housings with the internal seals and cartridge are available as KD42208-1 (for all but options R, S & T) and KD42210-2 (for options R, S & T).
 6. Items 3-23A through C are present only on units with serial numbers 2400 and larger.

15.0 **Obsolete Parts Information**

There is a long history of Eaton Carter brand lower half coupler changes that, through the years has not been particularly explained. The reasons for these changes are now lost, however we are providing a table that will detail the various couplers and the detail parts that were utilized in them. Many of these parts are no longer economical to continue to manufacture as spare parts hence we have made every effort to indicate the parts (kits) required to upgrade couplers older than the 42221-1.

The table below provides the history of the various Eaton Carter brand coupler lower halves. The exploded views provided in Figure 2 can be used as an assistance to identify the

required parts. The major pictorial differences between the newer and older couplers is in the Detent Pin (2-26) area. Older couplers, such as the 41609, used two detent pins and a retaining ring instead of the Ball (2-30). For this reasons it is not possible to totally interchange some of the parts on an item for item basis. The couplers are separated into two major areas:

- Linkage System
- Collar - Body - Detent Pin

The latter part of the table provides an indication as to the availability of the various parts or their substitutes where the inventory has been depleted.

**API Coupler Lower Half History
of Parts Interchangeability**

Crank Shaft - Poppet - Link Area:

Item	41609	42221	42221-1	42221-2	44665	44675
Crank Shaft	28756	42401	201422	200096 209996		210141
Pin	----	200785	----	-----		----
Cotter Pin	202010	98398D218	207521	207521 202010		202010
Washer	28762	GF960C616L	----	----- NAS1169C10		NAS1169C10
Link	(2) 28757	200687	201421	201421 209601		209601
Bearing	28765	----	28765	28765 28765		28765
Key	GF20066-205	201286	201286	GF20066-205 201286		201286
Pin (link)	28766	GF9390-690	GF16555-647	GF16555-647 210004		210004
Disc	(2) 28767	----	----	-----		----
Poppet	28754	200686	207991 202307	208069	209600	210139
Shaft	41740	----	----	-----		----
Shims	29381	----	----	-----		----

Collar - Body - Detent Pin Area:

Item	41609	42221	42221-1	42221-2	44665	44675
Collar	207481	200684	207482	207482	207482	207482
Snap Ring	RR-800-S	RR-787-S	RR-800-S	RR-800-S	RR-800-S	RR-800-S
Body	43944	200784	43945	43945	43945	43945
Detent Pin	(2) 28761	200689	200689	200689	200689	200689
Detent Lock	28764	GF9461-08	GF9461-08	GF9461-08	GF9461-08	GF9461-08

- Notes:
1. All part numbers beginning with "GF" are interchangeable with those beginning with either "AN" or "MS". If the "GF" is followed by three numbers it is interchangeable with and "AN" part, otherwise it is interchangeable with an "MS" part of the same number.
 2. The above table reflects the various parts used on each of the couplers shown and their superseding parts. It is not necessarily true that the various parts shown supersede the equivalent older part. The table below indicates the superseding part or kit of parts for each of the older items shown above. Where "limited stock" is indicated, it is the status as of April 1, 1996. Please ask your Eaton Carter brand distributor to check with us for the current situation.

Parts Support For Various Parts Used In Older Couplers

Ordered	Name	Replacement	Part Ordered Inventory Note
200096	Crank Shaft	210141	No longer available
200684	Collar	KD44665-3	No longer available
200686	Poppet	KD44665-2	No longer available
200687	Link	KD44665-2	No longer available
201421	Link	KD44665-2	Limited stock/check availability
201422	Crank Shaft	209996 or KD44665-5	No longer available To get lower cost cotter
202307	Poppet	KD44665-2	No longer available.
207481	Collar	44665	No longer available.
207521	Headed Pin	KD44665-2	Limited stock/check availability
207991	Poppet	KD44665-2	No Longer available.
208069	Poppet	KD44665-6	No longer available
28754	Poppet	KD44665-2	No longer available
28756	Crank Shaft	KD44665-2	No longer available
28757	Link	KD44665-2	Limited stock/check availability
42401	Crank Shaft	KD44665-2	No longer available.
28761	Detent Pin	44665	Limited stock/check availability
28764	Detent Lock	44665	No longer available.
28766	Pin	KD44665-2	Limited stock/check availability.
28767	Disc	KD44665-2	Limited stock/check availability
29381	Shim	KD44665-2	Limited stock/check availability
41740	Shaft	KD44665-2	No longer available
200785	Pin	KD44665-2	No longer available.
43944	Body	44665	Limited stock/check availability
GF16555-647	Pin	KD44665-2	No longer available.
GF9390-690	Pin	KD44665-2	No longer available

The kits mentioned above will provide various degrees of up grading of the older lower half couplers as explained below. The KD44665-1 Kit is included as a part of several of the upgrade/overhaul kits noted at the end of Table 1.

Kit Number	Description
KD44665-1	Upgrades linkage system to new configuration with necessary seals & other parts to overhaul lower half. Contains the following items (see Table 2.0): 2-9, 2-10, 2-11, 2-12, 2-13, 2-14, 2-15, 2-16, 2-17, 2-18, 2-20, 2-21, 2-22, 2-23 & 2-25.
KD44665-2	Upgrades linkage system to new configuration. Contains the following items (see Table 2.0): 2-9, 2-11, 2-12, 2-13, 2-14, 2-15, 2-16 & 2-20.
KD44665-3	Upgrades collar/ring to current configuration. Contains the following items (see Table 2.0): 2-27 & 2-29.
KD44665-4	Combines -1 & -3. Contains the following items (see Table 2.0): 2-9, 2-10, 2-11, 2-12, 2-13, 2-14, 2-15, 2-16, 2-17, 2-18, 2-20, 2-21, 2-22, 2-23, 2-25, 2-27 & 2-29.
KD44665-5	Upgrades Crank Shaft & Cotter in 41609 to new configuration. Contains the following items (see Table 2.0): 2-9, 2-11, 2-12 & 2-20.
KD44665-6	Upgrades linkage system in 42221-2 (short stroke) Couplers to new configuration. Contains the following items (see Table 2.0): 2-9, 2-11, 2-12, 2-13, 2-14, 2-16 & 210141 Crank Shaft & 210139 Poppet (parts used on Option S only).
KD44665-7	Same as -2 except rework instructions included to rework existing 210422 Crank Shaft (countersink to one boss required). Contains the following items (see Table 2.0): 2-11, 2-12, 2-13, 2-14, 2-15 & 2-16.

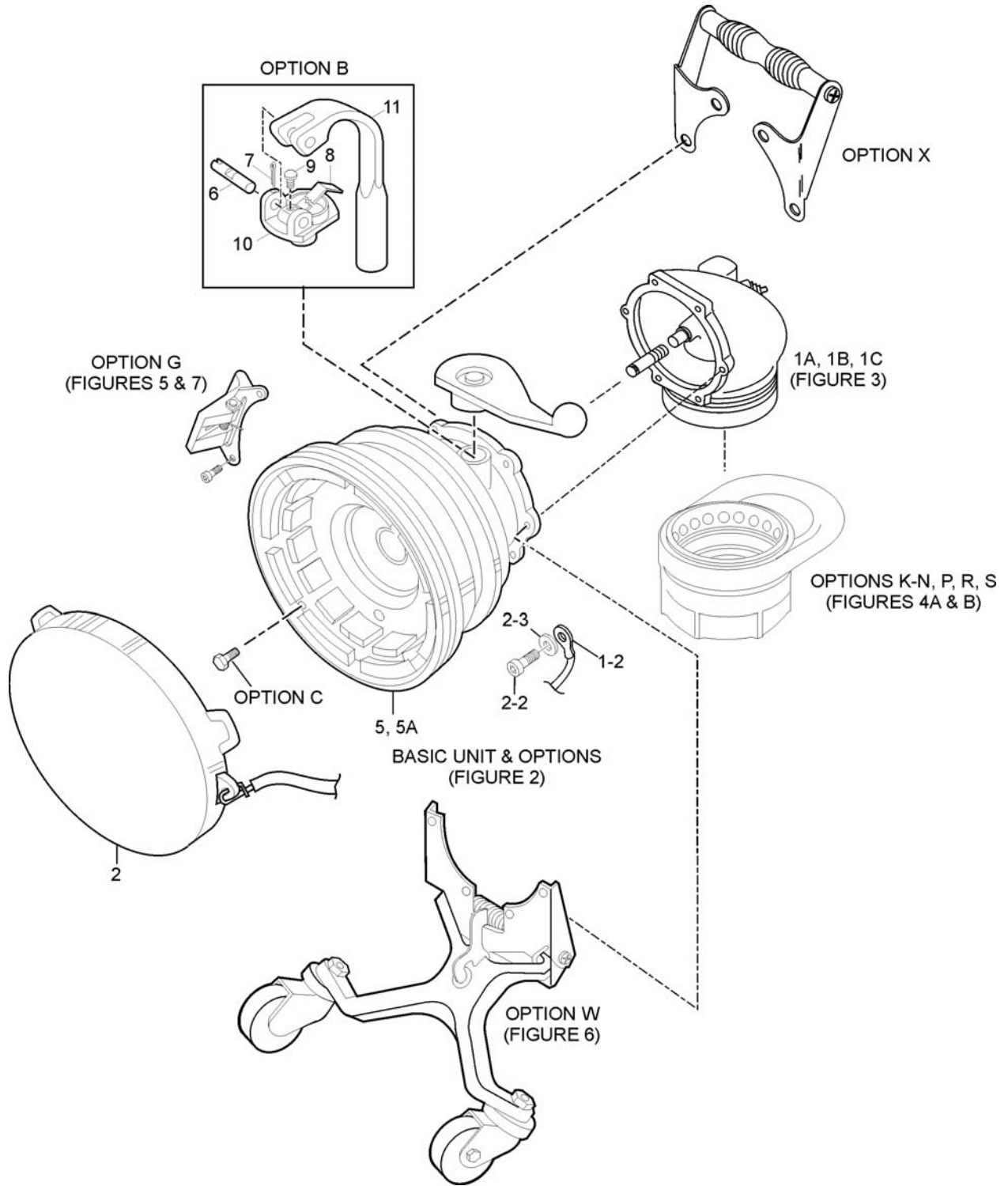
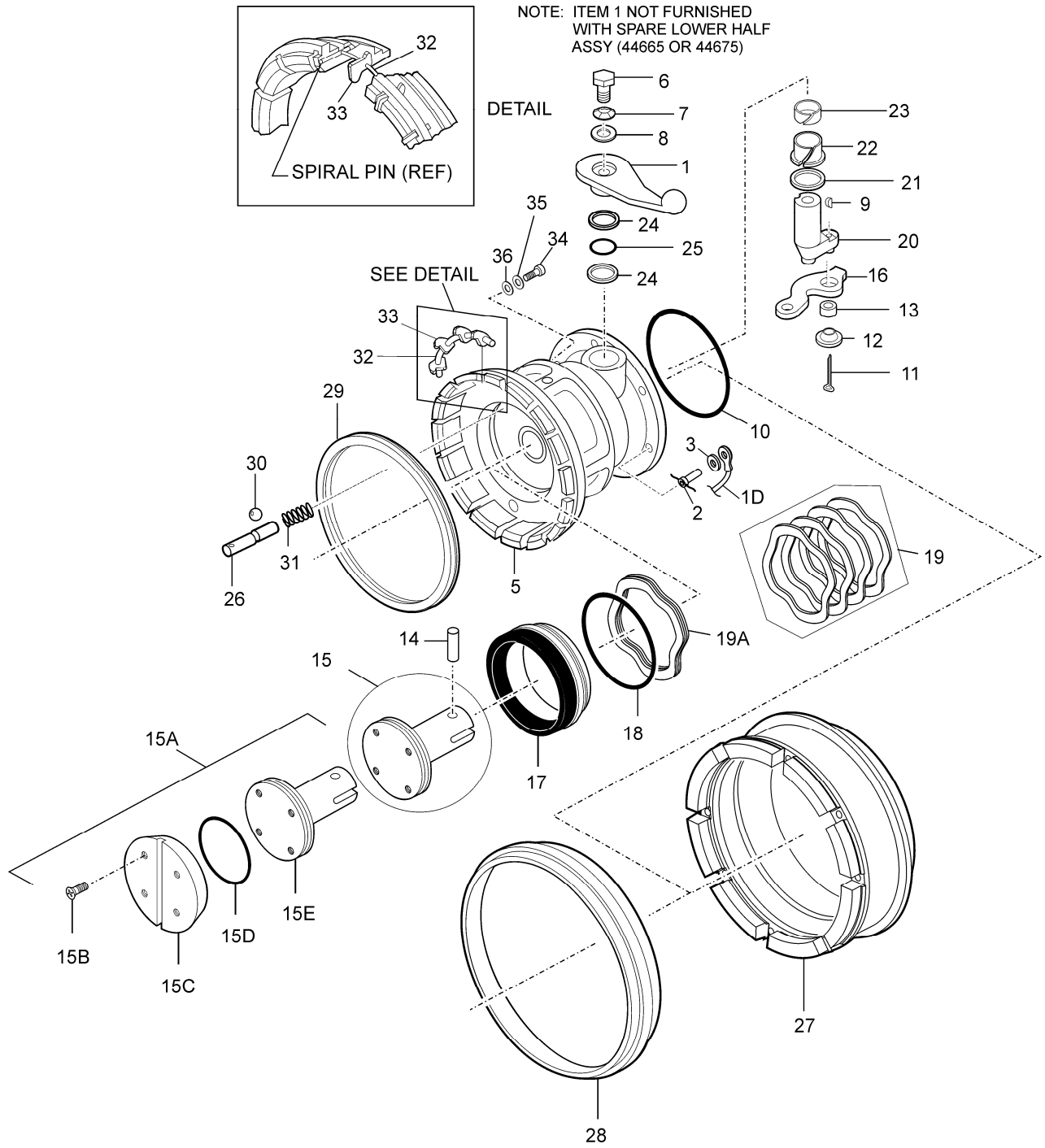
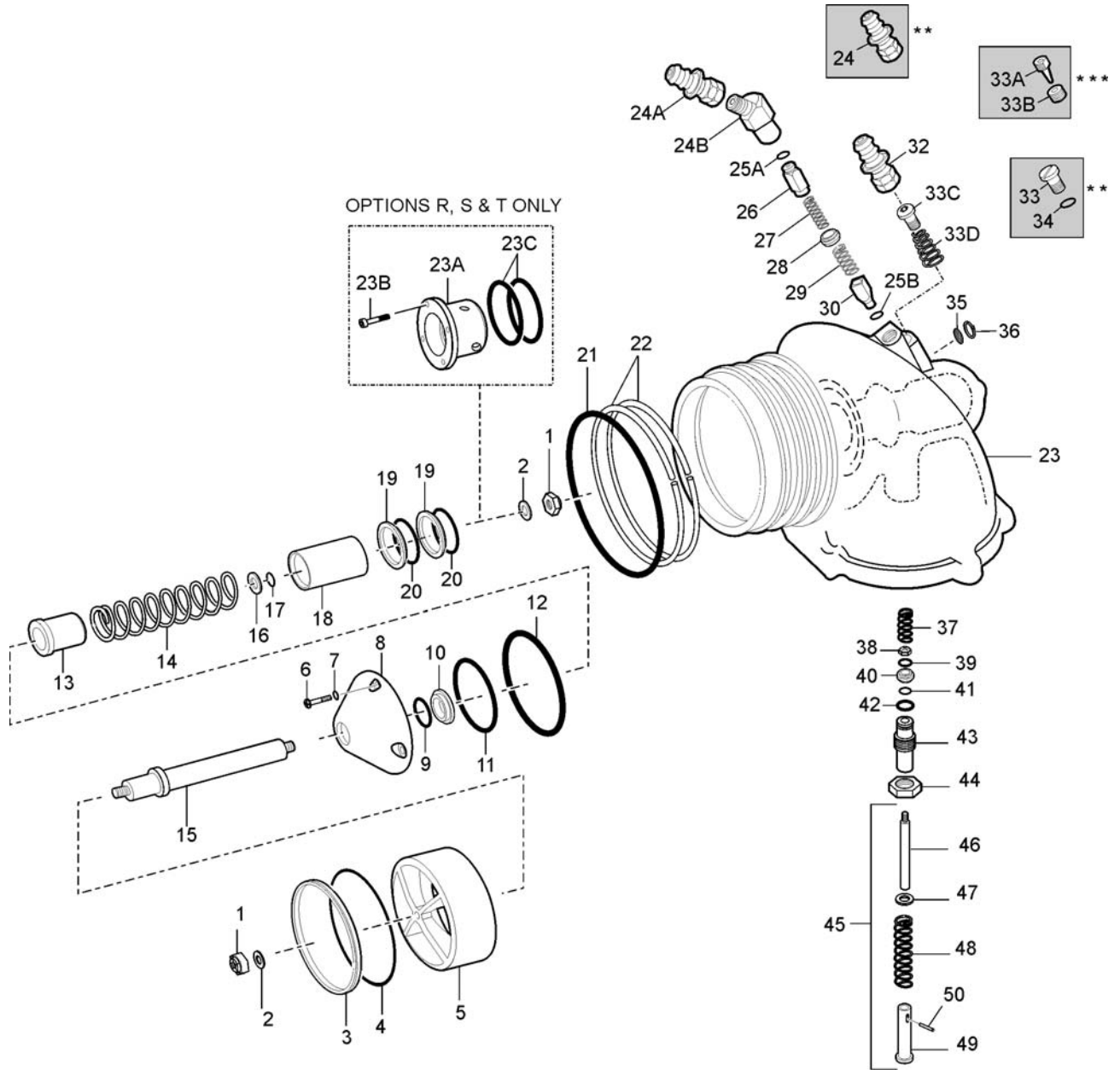

Figure 1
60700-1 Hydrant Coupler & Options





* See Figure 9 for details

** Replaced with 24A, 24B in later units

*** Replaced with 33C & 33D in later units

Figure 3

Pressure Control Elbow Assy

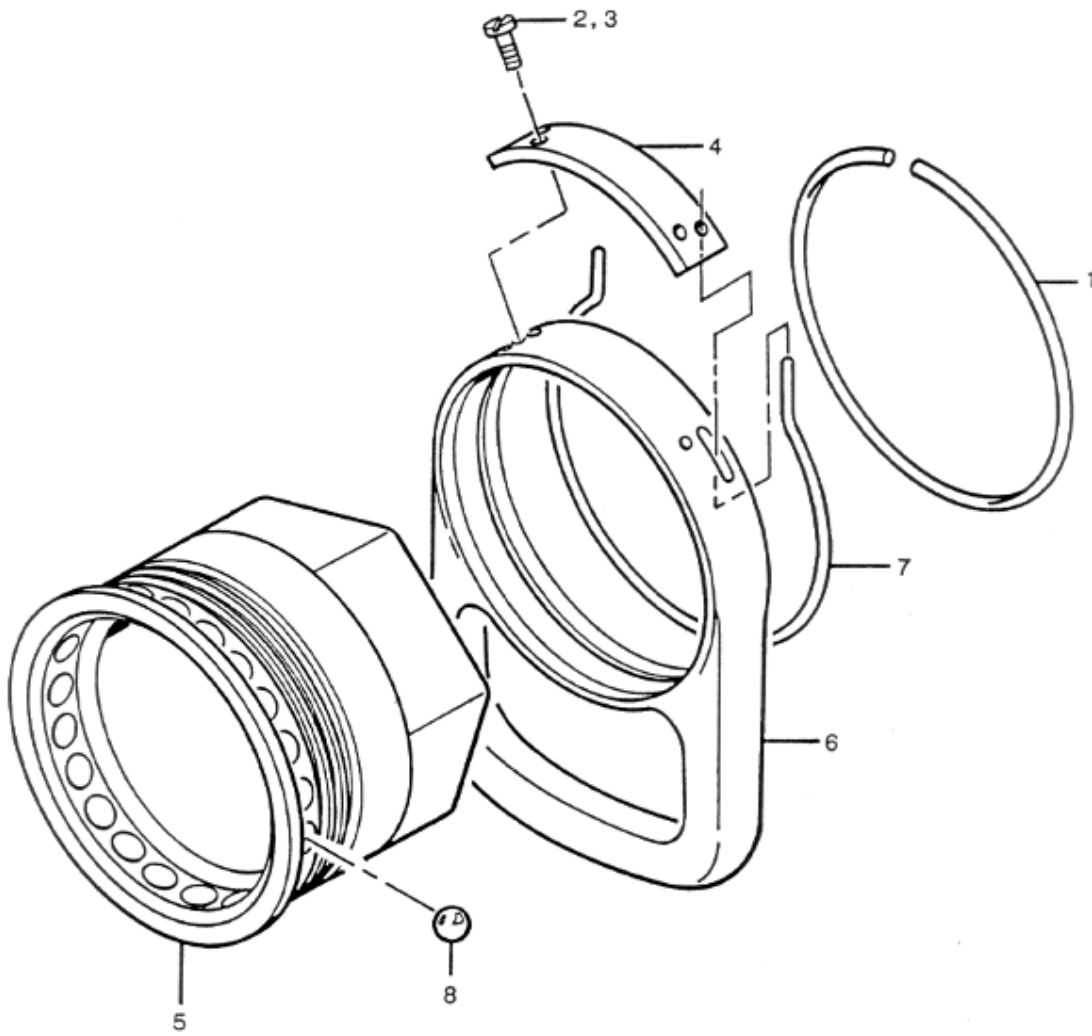

Figure 4A
Outlet, Female Half, 60700-1 Coupler
Options K-N & P

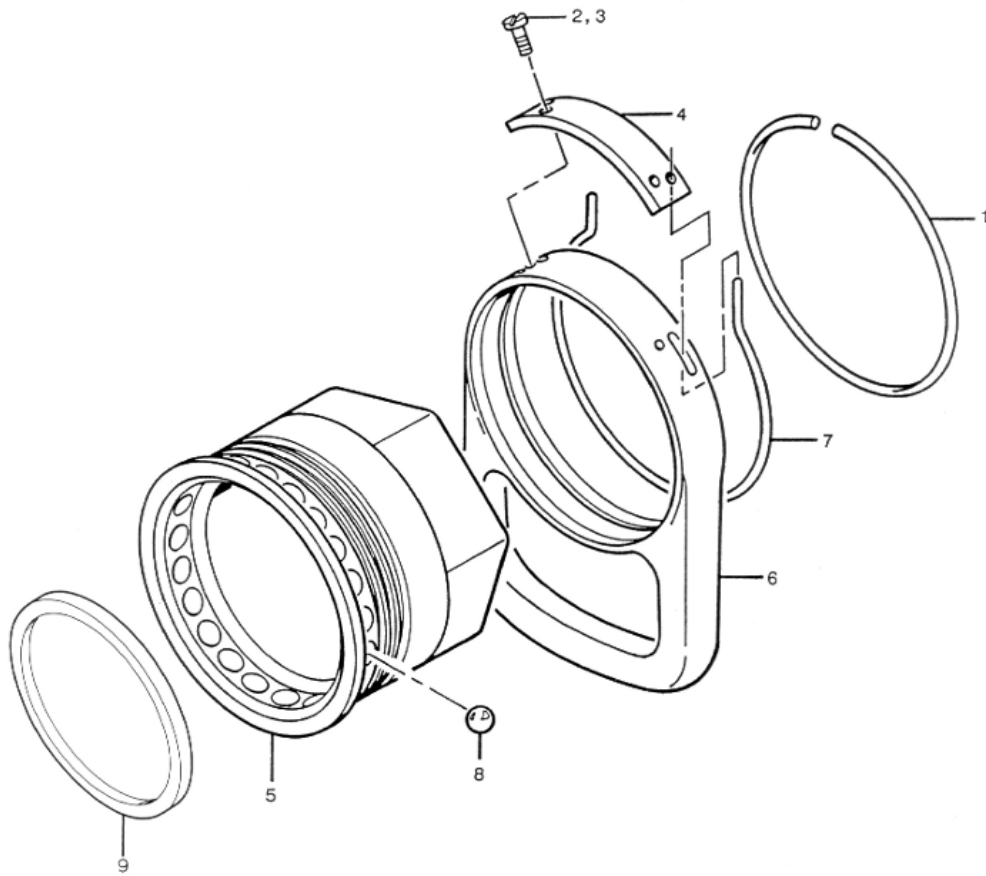

Figure 4B
Outlet, Female Half, 60700-1 Coupler
Options R & S

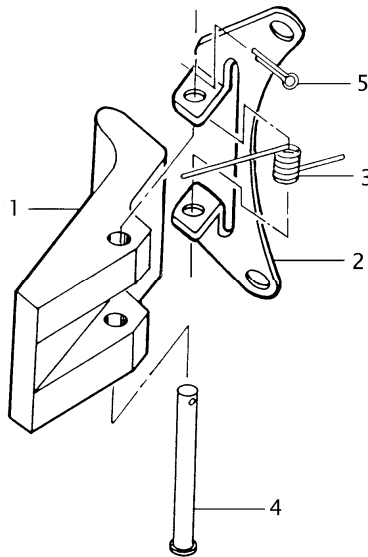

Figure 5
Collar Stop Lock Assembly
Option G

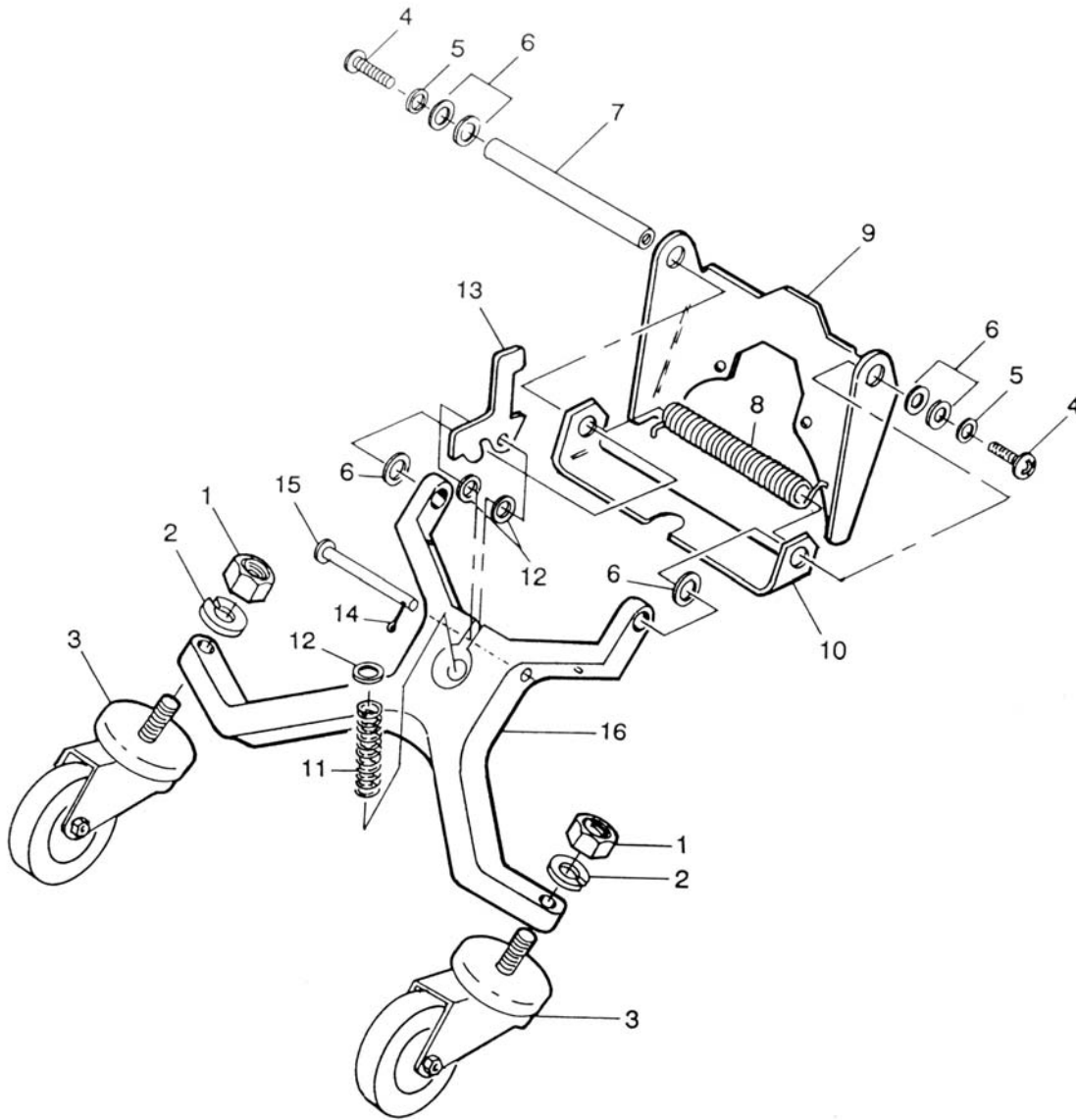

Figure 6
60523B Carriage Assembly

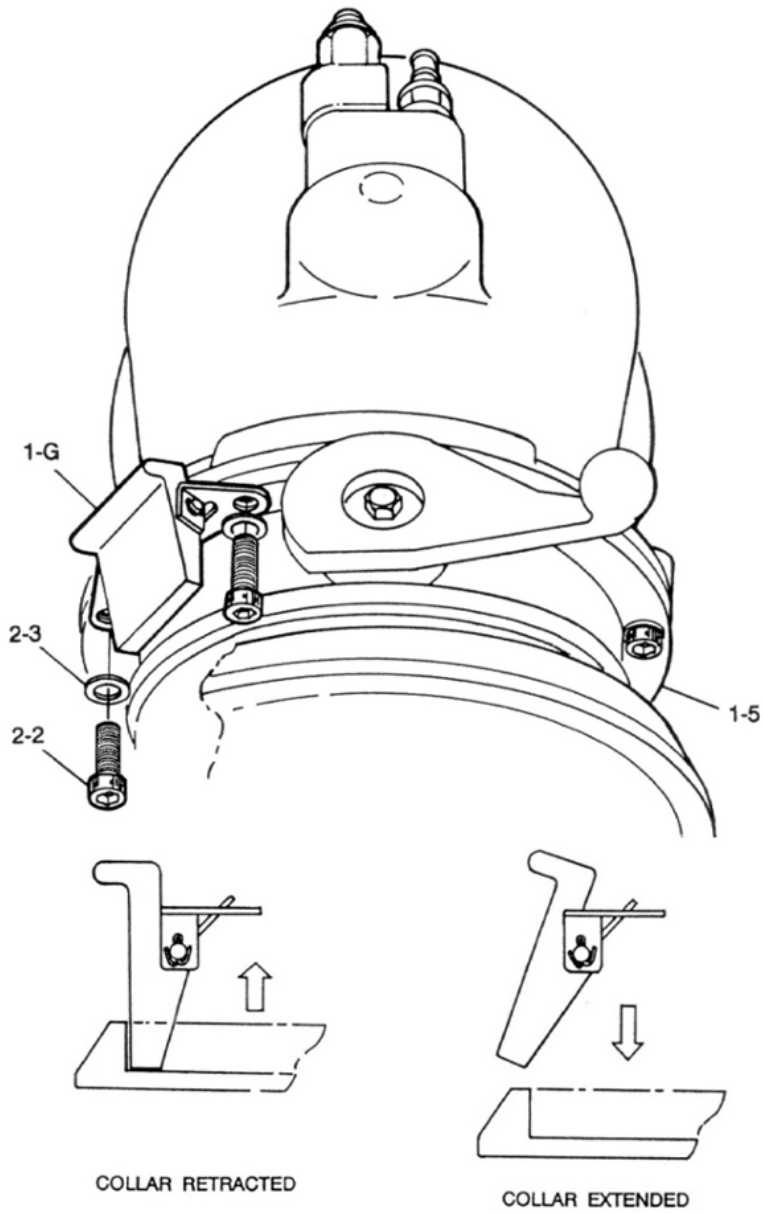
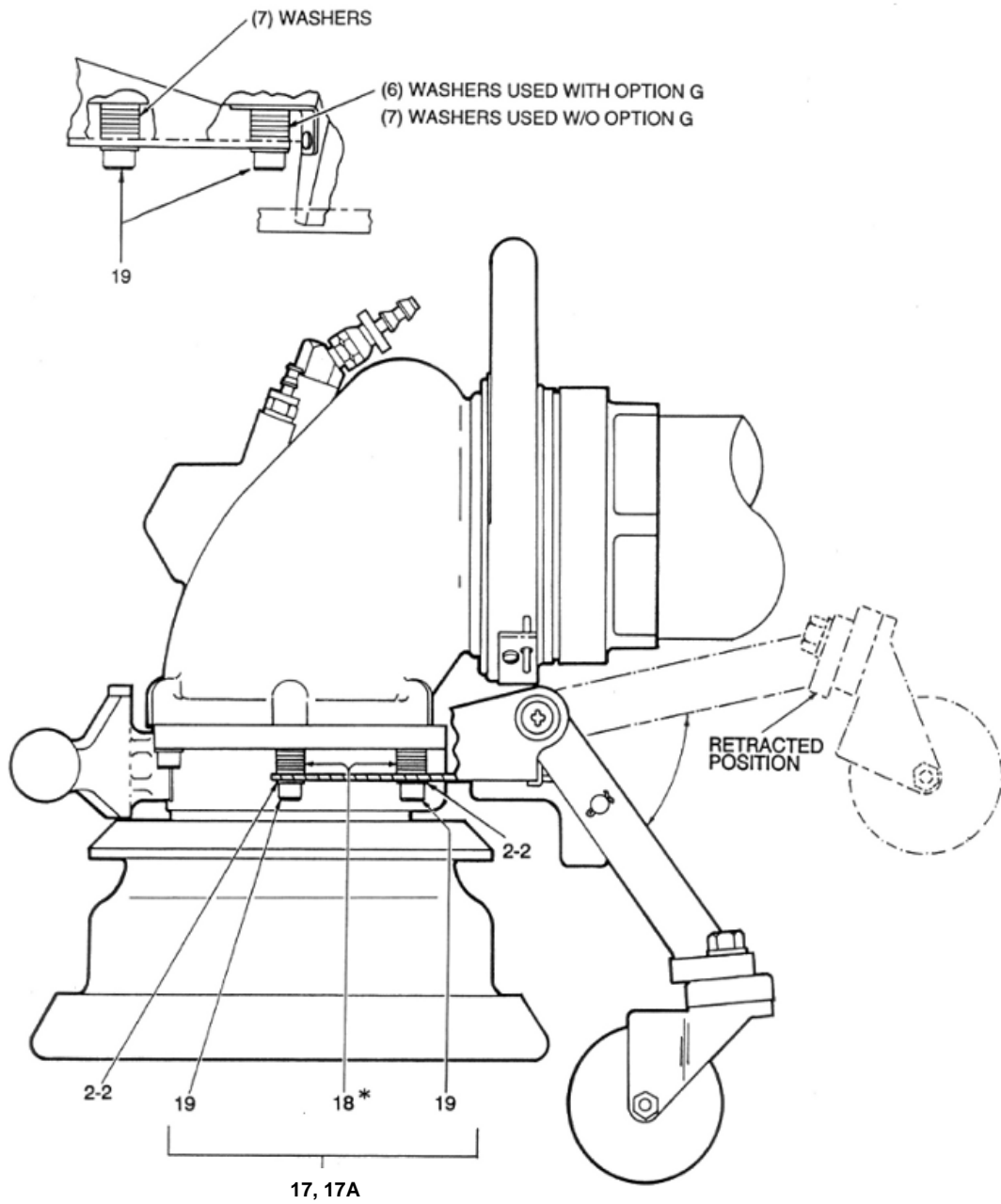

Figure 7
Option G Collar Lock Assembly
Mounting Instructions



* SOME UNITS HAVE ONE PIECE SPACERS

Figure 8
60532A Carriage Assembly

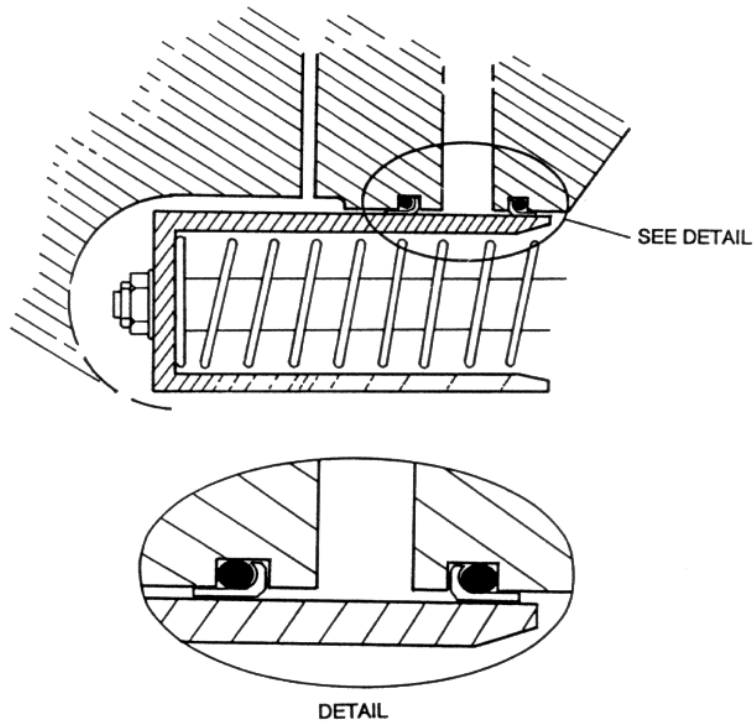

Figure 9
Inner Piston Seal Installation

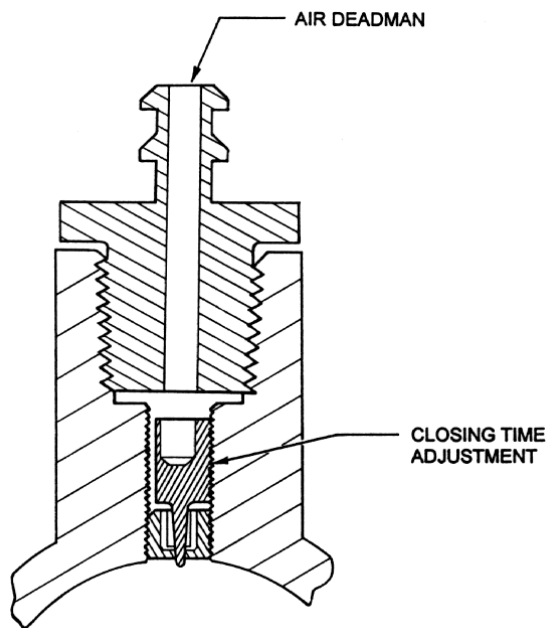

Figure 10
Air Orifice Adjustment

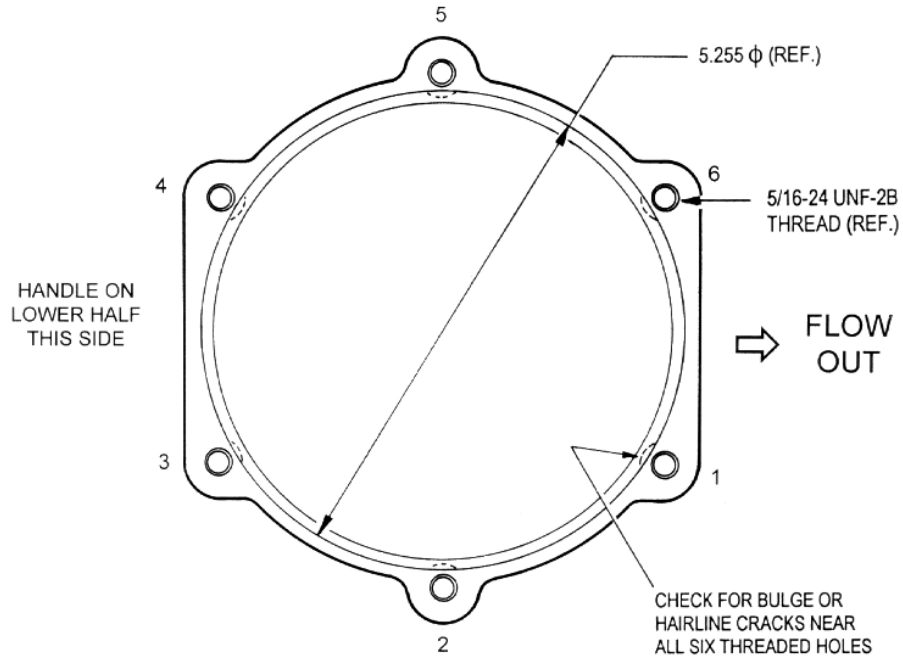

Figure 11
Coupler Upper Half Flange

Aerospace Group
Conveyance Systems Division
9650 Jeronimo Road
Irvine, CA 92618
Ph (949) 452-9500
Fax (949) 452-9500



Powering Business Worldwide