

Model 950B

2" - 12"

- Carbon steel or stainless steel
- Sizes 2" to 12"
- Flanged ANSI class 150 or 300

Features

- Offset inlet/outlet design
- Basket perforations from 1/32" to 1"
- 20 to 400 mesh linings for fine straining applications

Options

- Quick open cover or davit assembly bolted cover
- Alloy construction for body and baskets
- Construction according to "AD 2000-Merkblätter", DIN EN 13445 or ASME Code
- Steam jacket for highly viscous fluids
- Coatings and linings available upon request

Duplex housing for continuous operation

The Eaton Model 950B fabricated duplex strainers operate continuously and feature two strainer basket housings connected by four individually operated valves. When the basket in the first housing becomes full, switching the flow to the second is easy using the butterfly valve assembly. Remove, clean or replace the first basket for use again; the pipeline never shuts down.

Cover type openings

For applications with infrequent basket changing, Eaton offers a simple, cost-effective, bolted cover type. It's available with a davit assembly cover for larger strainers with heavy covers, this makes it possible for a one-person operation.

For applications with more frequent changing, Eaton offers a hinged, quick opening cover secured by swing bolts. This is adaptable for higher pressure applications. For medium size strainers, 8" to 12," a davit assembly bolted



12" Model 950B duplex strainer with quick open cover

cover is available. This permits one operator to engage the hinge and open the cover.

Strainer screens

Strainer screens are stainless steel or other specified materials.

Backflush/backwash option

In systems with heavy, well-defined solids and sediment, this option backflushes the system without shutting the system down. A piping connection with an on/off backflush valve is fabricated at the strainer bottom and has a connection to the bottom of the strainer basket. When solids accumulate in the bottom of the basket, the backflush valve opens and the differential between the oper-

ating pressure and the backflush system removes the solids. The second step, backwashing, reverses the flow and removes residual dirt.

Optional steam jacketing

Available in carbon steel or stainless steel rated for service up to 450 °F (232 °C). This is ideal for the high temperatures required to process and transport heavy, viscous fluids without affecting the function or normal maintenance of the strainer. Steam jacketing maintains critical fluid temperature throughout the strainer.

Design and fabrication to "AD 2000-Merkblätter", DIN EN 13445 or ASME Code and ANSI B31.1 are available.



Powering Business Worldwide

Model 950B 2" - 12" Fabricated Offset Duplex Strainer

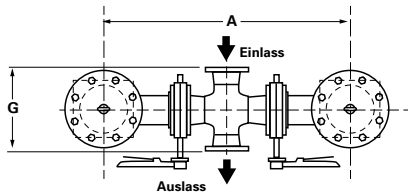

950 B 2"-6" bolted cover

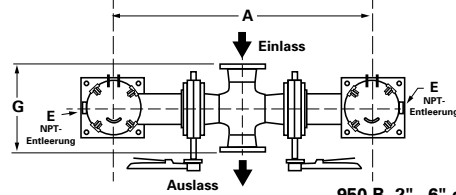
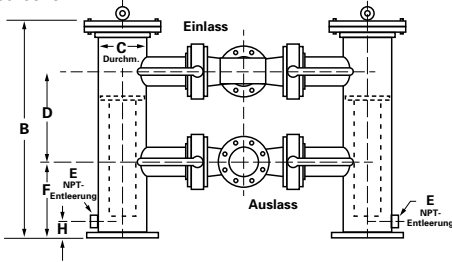

950 B 2"-6" quick open cover

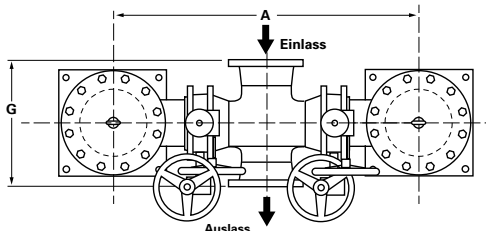
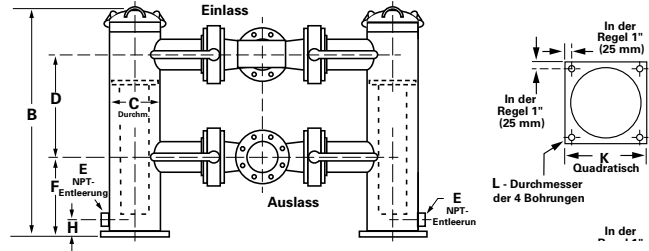

950 B 8"-12" bolted cover

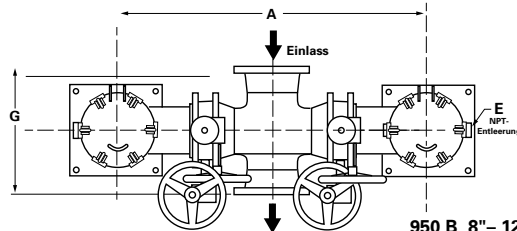
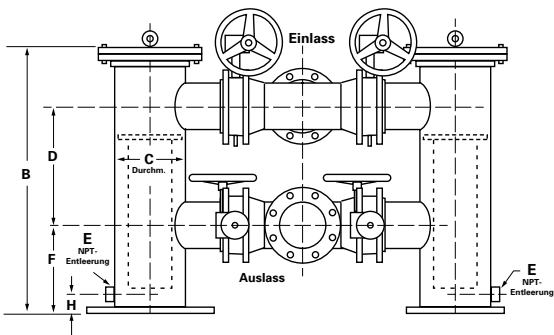

950 B 8"-12" quick open cover

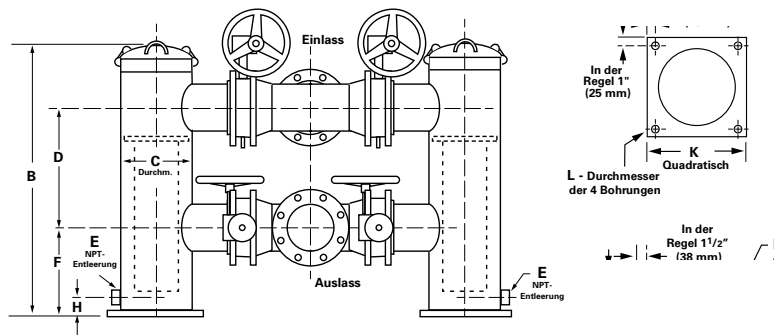

Dimensions (in/mm)

Pipe size	A	Quick open B	Bolted B	C	D	E	F	G	H	K	L	Weight quick open (lb / kg)	Weight bolted (lb / kg)
2	35.25 / 895	36.63 / 930	34.25 / 884	6.63 / 168	16.00 / 406	1	12.00 / 305	10.25 / 203	3.00 / 76	8.00 / 203	0.75 / 19	320 / 145	345 / 156
3	39.50 / 1003	38.63 / 981	38.00 / 965	6.63 / 168	16.00 / 406	1	14.00 / 356	12.50 / 318	3.00 / 76	8.00 / 203	0.75 / 19	410 / 186	430 / 195
4	43.75 / 1111	41.50 / 1054	41.00 / 1041	8.63 / 219	18.00 / 457	1	14.00 / 356	14.50 / 368	3.00 / 76	10.00 / 254	0.75 / 19	650 / 294	700 / 317
6	53.00 / 1346	43.25 / 1099	42.00 / 1087	10.75 / 273	18.00 / 457	1	14.00 / 356	18.50 / 470	3.00 / 76	12.00 / 305	0.75 / 19	1300 / 589	1100 / 499
8	56.25 / 1429	48.00 / 1219	46.00 / 1168	12.75 / 324	25.00 / 635	1-1/2	10.00 / 254	22.25 / 565	3.25 / 83	17.00 / 432	0.75 / 19	1685 / 763	1800 / 815
10	64.75 / 1645	51.75 / 1314	52.00 / 1321	16.00 / 406	26.00 / 660	1-1/2	10.00 / 254	25.25 / 641	3.50 / 89	19.00 / 483	0.75 / 19	2120 / 960	2300 / 1042
12	72.50 / 1842	57.75 / 1467	54.00 / 1372	18.00 / 457	28.00 / 711	1-1/2	12.00 / 305	29.25 / 743	4.00 / 102	21.00 / 533	1.00 / 25	3270 / 1481	3500 / 1586

North America
44 Apple Street
Tinton Falls, NJ 07724
Toll Free: 800 656-3344
(North America only)
Tel: +1 732 212-4700

Europe/Africa/Middle East
Auf der Heide 2
53947 Nettersheim, Germany
Tel: +49 2486 809-0

Internormen Product Line
Friedensstraße 41
68804 Altlufsheim, Germany
Tel: +49 6205 2094-0

Begerow Product Line
An den Nahewiesen 24
55450 Langenlonsheim, Germany
Tel: +49 6704 204-0

China
No. 3, Lane 280,
Linhong Road
Changning District, 200335
Shanghai, P.R. China
Tel: +86 21 5200-0099

Singapore
4 Loyang Lane #04-01/02
Singapore 508914
Tel: +65 6825-1668

Brazil
Av. Julia Gaioli, 474 - Bonsucesso
07251-500 - Guarulhos, Brazil
Tel: +55 11 2465-8822

For more information, please
email us at filtration@eaton.com
or visit www.eaton.com/filtration

© 2014 Eaton. All rights reserved. All trademarks and registered trademarks are the property of their respective owners. All information and recommendations appearing in this brochure concerning the use of products described herein are based on tests believed to be reliable. However, it is the user's responsibility to determine the suitability for his own use of such products. Since the actual use by others is beyond our control, no guarantee, expressed or implied, is made by Eaton as to the effects of such use or the results to be obtained. Eaton assumes no liability arising out of the use by others of such products. Nor is the information herein to be construed as absolutely complete, since additional information may be necessary or desirable when particular or exceptional conditions or circumstances exist or because of applicable laws or government regulations.

US
EF-SSEA-20
6-2014