

Model 950B

14" - 24"

- Carbon steel or stainless steel
- Sizes 14" to 24"
- Flanged ANSI class 150 or 300

Features

- Offset inlet/outlet design
- Basket perforations from 1/32" to 1"
- 20 to 400 mesh linings for fine straining applications

Options

- Quick open cover or davit assembly bolted cover
- Alloy construction for body and baskets
- Construction according to "AD 2000-Merkblätter", DIN EN 13445 or ASME Code
- Steam jacket for highly viscous fluids
- Coatings and linings available upon request

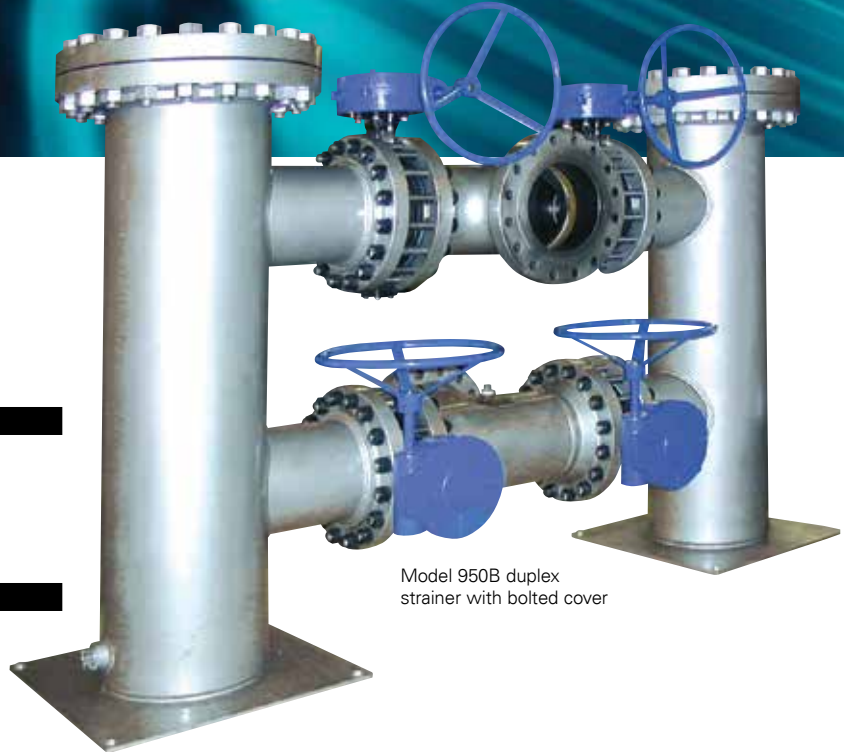

Model 950B duplex strainer with bolted cover

Duplex housing for continuous operation

The Eaton Model 950B fabricated duplex strainers operate continuously and feature two strainer basket housings connected by valves. When the basket in the first housing becomes full, switching the flow to the second is easy using the butterfly valve assembly. Remove, clean or replace the first basket for use again; the pipeline never shuts down.

Cover type openings

For applications with infrequent basket changing, Eaton offers a simple, cost-effective, bolted cover type. It's available with a davit assembly cover for larger strainers with heavy covers, this makes it possible for a one-person operation.

For applications with more frequent changing, Eaton offers a hinged, quick opening cover secured by swing bolts. This is adaptable for higher

pressure applications. For medium size strainers, 14" to 16," a davit assembly bolted cover is available. This permits one operator to engage the hinge and open the cover.

Strainer screens

Strainer screens are stainless steel or other specified materials.

Backflush/backwash option

In systems with heavy, well-defined solids and sediment, this option backflushes the system without shutting it the system down. A piping connection with an on/off backflush valve is fabricated at the strainer bottom and has a connection to the bottom of the strainer basket. When solids accumulate in the bottom of the basket, the backflush valve opens and the differential between the

operating pressure and the backflush system removes the solids. The second step, backwashing, reverses the flow and removes residual dirt.

Optional steam jacketing

Available in carbon steel or stainless steel rated for service up to 450 °F (232 °C). This is ideal for the high temperatures required to process and transport heavy, viscous fluids without affecting the function or normal maintenance of the strainer. Steam jacketing maintains critical fluid temperature throughout the strainer.

Eaton customizes the strainers to meet special application requirements. Design and fabrication to "AD 2000-Merkblätter", DIN EN 13445 or ASME Code and ANSI B31.1 are available.



Powering Business Worldwide

Model 950B 14" - 24" Fabricated Offset Duplex Strainer

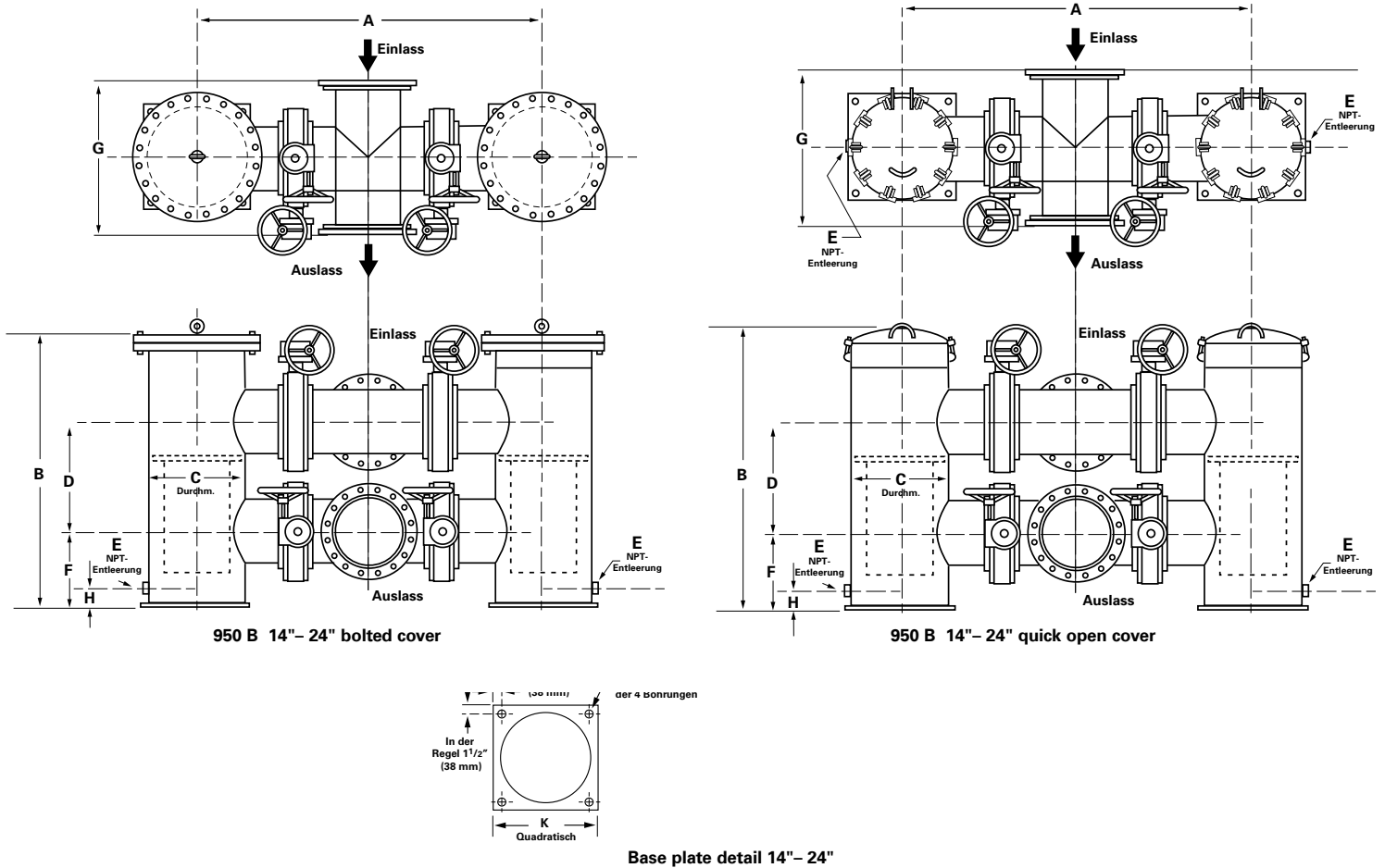

Dimensions (in/mm)

Pipe size	Quick open		Bolted		D	E	F	G	H	K	Weight		
	A	B	B	C							(lb/kg)	(lb/kg)	
14	84.00 / 2134	63.00 / 1600	63.00 / 1600	20.00 / 508	27.00 / 685	1-1/2	16.00 / 406	32.00 / 813	4.00 / 102	23.00 / 584	1.00 / 25	3700 / 1678	4000 / 1814
16	86.00 / 2184	68.00 / 1727	68.00 / 1727	24.00 / 610	27.00 / 685	1-1/2	18.00 / 457	34.00 / 864	4.00 / 102	26.00 / 660	1.13 / 29	4240 / 1923	4680 / 2123
18	90.00 / 2286	73.00 / 1854	69.00 / 1753	24.00 / 610	30.00 / 762	2	19.00 / 483	38.00 / 965	4.75 / 121	26.00 / 660	1.13 / 29	5760 / 2613	6200 / 2813
20	106.00 / 2692	90.00 / 2286	90.00 / 2286	30.00 / 762	36.00 / 914	2	22.00 / 559	40.00 / 1016	4.75 / 121	38.00 / 965	1.13 / 29	8450 / 3833	8900 / 4037
24	121.00 / 3073	100.00 / 2540	100.00 / 2540	30.00 / 762	48.00 / 1219	2	24.00 / 610	48.00 / 1168	4.75 / 121	38.00 / 965	1.13 / 29	9300 / 4354	10050 / 4559

North America
44 Apple Street
Tinton Falls, NJ 07724
Toll Free: 800 656-3344
(North America only)
Tel: +1 732 212-4700

Europe/Africa/Middle East
Auf der Heide 2
53947 Nettersheim, Germany
Tel: +49 2486 809-0

Internormen Product Line
Friedensstraße 41
68804 Altlufsheim, Germany
Tel: +49 6205 2094-0

Begerow Product Line
An den Nahewiesen 24
55450 Langenlonsheim, Germany
Tel: +49 6704 204-0

China
No. 3, Lane 280,
Linhong Road
Changning District, 200335
Shanghai, P.R. China
Tel: +86 21 5200-0099

Singapore
4 Loyang Lane #04-01/02
Singapore 508914
Tel: +65 6825-1668

Brazil
Av. Julia Gaioli, 474 – Bonsucesso
07251-500 – Guarulhos, Brazil
Tel: +55 11 2465-8822

For more information, please
email us at filtration@eaton.com
or visit www.eaton.com/filtration

© 2014 Eaton. All rights reserved. All trademarks and registered trademarks are the property of their respective owners. All information and recommendations appearing in this brochure concerning the use of products described herein are based on tests believed to be reliable. However, it is the user's responsibility to determine the suitability for his own use of such products. Since the actual use by others is beyond our control, no guarantee, expressed or implied, is made by Eaton as to the effects of such use or the results to be obtained. Eaton assumes no liability arising out of the use by others of such products. Nor is the information herein to be construed as absolutely complete, since additional information may be necessary or desirable when particular or exceptional conditions or circumstances exist or because of applicable laws or government regulations.

US
EF-SSEA-21
6-2014