

PIPE SIZE (NOMINAL)	DIMENSIONS										APPROX. WEIGHT LBS. KG	PART NO.
	A IN. MM	B IN. MM	C IN. MM	D IN. MM	E IN. MM	F IN. MM	G IN. MM	H IN. MM	K IN. MM	L IN. MM		
8 (200mm)	56.25/ 1429	46.00/ 1168	12.75/ 324	25.00/ 635	1-1/2/ 40	10.00/ 254	22.25/ 565	3.25/ 83	17.00/ 432	0.75/ 19	1800/ 815	ST952080BR3BA
10 (250mm)	64.75/ 1645	52.00/ 1321	16.00/ 406	26.00/ 660	1-1/2/ 40	10.00/ 254	25.25/ 641	3.50/ 89	19.00/ 483	0.75/ 19	2300/ 1042	ST952100BR3BA
12 (300mm)	72.50/ 1842	54.00/ 1372	18.00/ 457	28.00/ 711	1-1/2/ 40	12.00/ 305	29.25/ 743	4.00/ 102	21.00/ 533	1.00/ 25	3500/ 1586	ST952120BR3BA

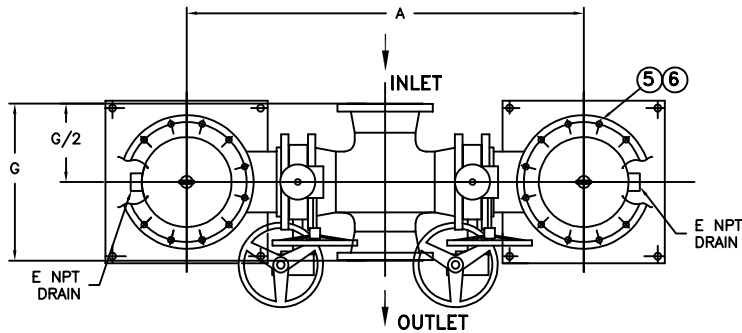

ASSEMBLY PLAN VIEW

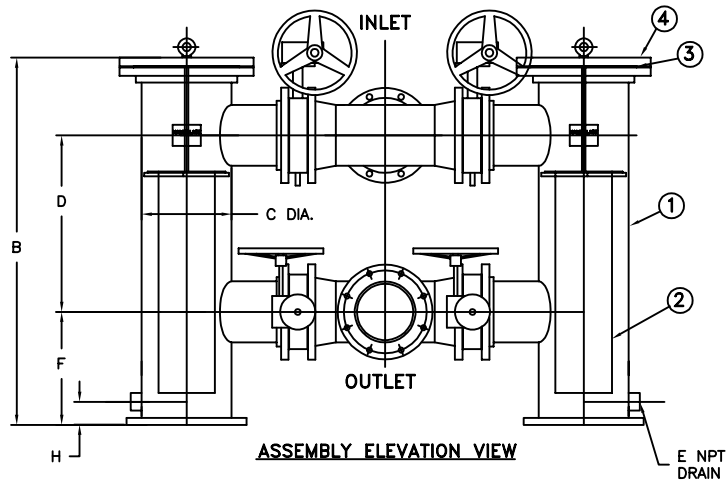

ASSEMBLY ELEVATION VIEW

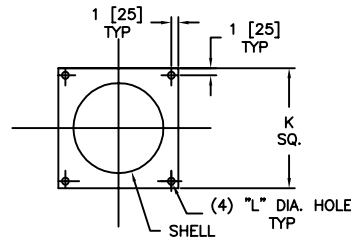

BASE PLATE DETAIL

NO.	PART NAME	MATERIAL
1	BODY	CARBON STEEL
2	BASKET	-
	PERF. DIA.	-
	MESH	-
3	GASKET	NON ASBESTOS
4	COVER	CARBON STEEL
5	BOLTS	A 193 B7
6	NUTS	A 194 2H

NOTES:

- UNITS ARE DESIGNED & FABRICATED AND "U" STAMPED (IF REQ'D.) IN ACCORDANCE WITH THE ASME BOILER & PRESSURE VESSEL CODE SECTION VIII, DIVISION 1, IN COMPLIANCE TO CURRENT PUBLISHED ADDENDA.
- ALL BOLT HOLES STRADDLE NATURAL CENTERLINES.
- ALL DIMENSIONS ARE IN INCHES [MM].
- ALL FITTINGS CONFORM WITH ASME B16.5.
- DESIGN PRESSURE: 150 PSIG @ 150°F
(10.3 BARG @ 65.6°C)
MDMT: -20°F @ 150 PSIG
(MDMT: -28.9°C @ 10.3 BAR)
- VALVES: BUTTERFLY VALVE, WAFER STYLE, C.I. BODY, D.I. DISC, S. STEEL SHAFT, PTFE BUSHING, EPDM SEATS W/ GEAR OPERATOR
- PAINT: PER STD. ES-309

CERTIFIED FOR:

P.O. NO.:

REG. NO.:

QUOTE NO.:

TAG NO.:

		EATON FILTRATION, LLC	
		900 FAIRMOUNT AVENUE, ELIZABETH, NEW JERSEY 07207	
NAME		MODEL 950B DUPLEX STRAINER 150# RF FLANGE BOLTED COVER SIZES 8", 10", 12" CARBON STEEL	
DRAWN	LH	DATE	05/16/07
CERT.	FM	DATE	05/17/2007
SIZE	DWG	SD952BC2	
A	NO	REV	
		B	

ELECTRONIC FILE NAME: SD952BC2.DWG
REF. ECR 0053999 DATE 03/11/11

UNAUTHORIZED USE, MANUFACTURE OR REPRODUCTION IN WHOLE OR IN PART IS PROHIBITED. DRAWING, DESIGN AND OTHER DISCLOSURES PROPERTY OF EATON FILTRATION, LLC