

PIPE SIZE (NOMINAL)	DIMENSIONS			APPROX. WEIGHT (DRY) LBS. (KGS)	PART NO.
	"A" IN. (MM)	"B" IN. (MM)	"C" IN. (MM)		
2 (50mm)	10.62 / 270	6.19 / 157	15.00 / 381	45 / 20.4	ST091020DR2BA
3 (80mm)	13.12 / 333	7.69 / 195	18.00 / 457	85 / 38.6	ST091030DR2BA
4 (100mm)	15.12 / 384	8.81 / 224	21.00 / 533	120 / 54.4	ST091040DR2BA
5 (125mm)	17.62 / 448	10.25 / 260	24.00 / 610	160 / 72.6	ST091050DR2BA

REVISIONS				
REV	DESCRIPTION	BY	ECO	DATE
H	UPDATE TITLE BLOCK	FM	0104921	11/24/2014

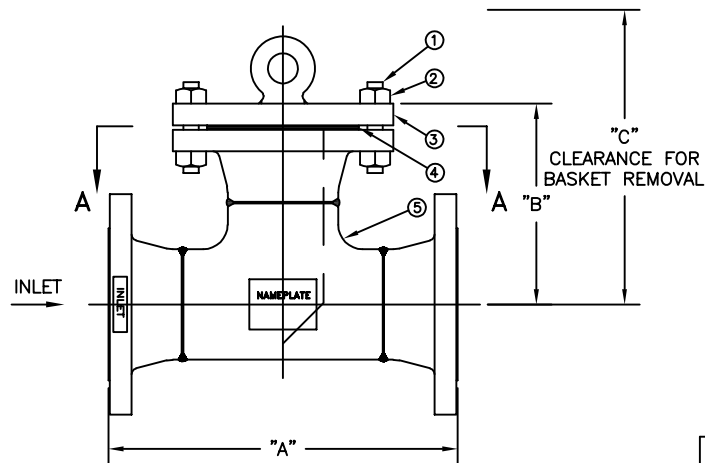
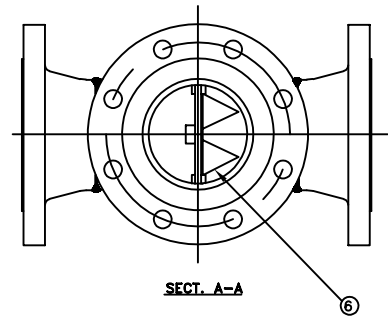

NO.	PART NAME	MATERIAL
1	STUDS	ASTM A193 GR. B7
2	NUTS	ASTM A194 GR. 2H
3	COVER	STAINLESS STEEL
4	GASKET	NON-ASBESTOS
5	BODY	STAINLESS STEEL
6	BASKET	316 SSTL
	PERF. / MESH	

NOTES:

1. STRAINER IS DESIGNED AND FABRICATED IN ACCORDANCE WITH ASME B31.1 POWER PIPING CODE.
2. ALL DIMENSIONS ON IN INCHES / MM.
3. ALL FITTINGS CONFORM TO ASME STANDARD.
4. DESIGN PRESSURE: 670 PSIG @ 150' F (46.2 BAR @ 65.6'C)
515 PSIG @ 400' F (35.5 BAR @ 204.4'C)

CUSTOMER INFO	
NAME	
P.O. NO.	
TAG NO.	
S.O. NO.	
PART NO.	SEE TABLE

DRAWN BY AB	RESTRICTION RESTRICTED
SCALE AS DRAWN	
SHEET 1 OF 1	
PROJECTION THIRD ANGLE	DATE 10/6/97

EATON HYDRAULICS GROUP
FILTRATION DIVISION
GALESBURG, MICHIGAN, USA • TINTON FALLS, NEW JERSEY, USA

TITLE
MODEL 91 TEE STRAINER BOLTED COVER
SIZES 2" TO 5" 300#RF FLANGE STAINLESS STEEL

SIZE A	DWG FILENAME SD091BC4	REV H
-----------	--------------------------	----------

EATON CORPORATION - CONFIDENTIAL AND PROPRIETARY NOTICE TO PERSONS RECEIVING THIS DRAWING AND/OR TECHNICAL INFORMATION
THIS DOCUMENT, INCLUDING THE DRAWING AND INFORMATION CONTAINED THEREON IS CONFIDENTIAL AND IS THE EXCLUSIVE PROPERTY OF EATON AT ANY TIME. BY TAKING THE POSSESSION OF THIS DOCUMENT THE RECIPIENT ACKNOWLEDGES AND AGREES THAT THIS DOCUMENT CANNOT BE USED IN ANY MANNER ADVERSE TO THE INTEREST OF EATON AND THAT NO PORTION OF THIS DRAWING MAY BE COPIED OR OTHERWISE REPRODUCED WITHOUT THE PRIOR WRITTEN CONSENT OF EATON, IN THE CASE OF CONFLICTING CONTRACTUAL PROVISIONS, THIS NOTICE SHALL GOVERN THE STATUS OF THIS DOCUMENT.
2014 EATON CORPORATION - ALL RIGHTS RESERVED.