

Fabricated Simplex Strainer

Model 90

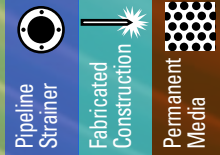

8" Model 90 strainer, carbon steel with bolted cover

- Carbon steel or stainless steel*
- Sizes 1" to 48"
- Flanged ANSI class 150 or 300

Features

- Straight through flow design
- Low pressure loss
- Slant top basket design
- Basket perforations from 1/32" to 1"
- 20 to 400 mesh linings for fine straining applications

Options

- ANSI Class 600, 900, 1500 or DIN EN flanges
- European standards - DIN/PED available
- Hinged cover or davit assembly for easier maintenance
- Alloy construction for body and baskets
- RTJ-style connections
- Vent valves
- Drain valves
- Gauge taps
- Backflushing system for manual or automated cleaning
- Pressure differential gauge and switches
- Steam jacket for highly viscous fluids
- Rotated or offset nozzle placement
- High pressure capabilities
- Construction according to "AD 2000-Merkblätter", DIN EN 13445 or ASME Code
- Brazilian NR-13 available
- Coatings and linings available upon request

* Stainless steel strainers include painted carbon steel, external, non-wetted fasteners as standard

Customize to improve performance and meet higher pressure requirements

A slant top design improves the flow through the strainer and results in significantly lower pressure drops. This design also results in a more compact basket that weighs less than an ordinary basket. This makes it possible for one person to remove it from the strainer housing, when it comes time to clean or changeout the basket.

Common modifications

- Rotated inlet and outlet nozzles to eliminate an elbow in the downstream piping
- Lowering or raising either the inlet or the outlet nozzle, this eliminates serious alignment and support problems.

Cover type openings

For applications with infrequent basket changing, Eaton offers a simple, cost-effective, bolted cover type. It's available with a davit assembly cover for larger strainers with heavy covers, this makes it possible for a one-person operation.

For applications with more frequent changing, Eaton offers a hinged, quick opening cover secured by swing bolts. This is adaptable for higher pressure applications. For

medium size strainers, 8" to 16," a davit assembly bolted cover is available. This permits one operator to engage the hinge and open the cover.

Backflush/backwash option

In systems with heavy, well-defined solids and sediment, this option backflushes the system without shutting the system down. A piping connection with an on/off backflush valve is fabricated at the strainer bottom and has a connection to the bottom of the strainer basket. When solids accumulate in the bottom of the basket, the backflush valve opens and the differential between the operating pressure and the backflush system removes the solids. The second step, backwashing, reverses the flow and removes residual dirt.

Optional steam jacketing

Available in carbon steel or stainless steel rated for service up to 450 °F (232 °C). This is ideal for the high temperatures required to process and transport heavy, viscous fluids without affecting the function or normal maintenance of the strainer. Steam jacketing maintains critical fluid temperature throughout the strainer.

Design and fabrication "AD 2000-Merkblätter", DIN EN 13445 or ASME Code and ANSI B31.1 are available.



Powering Business Worldwide

Model 90 Fabricated Simplex Strainer

Model 90 with quick open hinge cover

Nom size	Dimensions (in / mm)							Weight (lb / kg)			
	Class 150	Class 300	B	Class 150/300		E	F	Class 150		Class 300	
	A	A		C	D			Cover	Unit	Cover	Unit
2	14 / 356	14 / 356	12 / 305	8 5/8 / 219	6 5/8 / 168	1/2	26 / 660	6 / 2.7	71 / 32	6 / 2.7	90 / 41
3	15 / 381	15 / 381	12 1/2 / 318	8 5/8 / 219	6 5/8 / 168	1/2	26 / 660	6 / 2.7	73 / 33	6 / 2.7	105 / 48
4	16 / 406	16 / 406	14 / 356	9 1/2 / 241	8 5/8 / 219	1	21 / 533	9 / 4.1	122 / 55	9 / 4.1	158 / 72
5	16 / 406	17 1/2 / 445	15 / 381	11 1/4 / 286	10 3/4 / 273	1	22 / 559	9 / 4.1	128 / 58	9 / 4.1	176 / 80
6	20 / 508	21 / 533	17 / 432	11 1/4 / 286	10 3/4 / 273	1	24 / 610	12 / 5.4	168 / 76	12 / 5.4	236 / 107
8	22 / 559	23 / 584	21 / 533	13 / 330	12 3/4 / 324	1 1/2	28 / 711	15 / 6.8	226 / 103	15 / 6.8	278 / 126
10	32 / 813	33 / 838	25 / 635	15 3/4 / 400	16 / 406	1 1/2	33 / 838	30 / 14	360 / 163	30 / 14	483 / 219
12	35 / 889	36 / 914	28 / 711	17 3/4 / 451	18 / 457	1 1/2	39 / 991	37 / 17	535 / 243	37 / 17	734 / 333
14	37 / 940	38 / 965	33 / 838	19 3/4 / 502	20 / 508	2	45 / 1143	46 / 21	804 / 365	46 / 21	1030 / 467
16	42 / 1067	43 / 1092	36 / 914	23 1/4 / 591	24 / 610	2	49 / 1245	68 / 31	1188 / 539	68 / 31	1437 / 652
18	42 / 1067	43 / 1092	39 / 991	23 1/4 / 591	24 / 610	2	53 / 1346	68 / 31	1255 / 569	68 / 31	1553 / 704
20	43 / 1092	44 1/2 / 1130	44 / 1118	27 3/4 / 705	30 / 762	2	59 / 1499	71 / 32	1322 / 600	71 / 32	1656 / 751
24	48 / 1219	49 3/4 / 1264	60 / 1524	27 3/4 / 705	30 / 762	2	78 / 1981	88 / 40	1860 / 844	88 / 40	2344 / 1063

Model 90 with bolted cover

Nom-size	Dimensions (in / mm)							Weight (lb / kg)				
	Class 150	Class 300	B	Class 150	Class 300	E	F	Class 150		Class 300		
	A	A		C	C			Cover	Unit	Cover	Unit	
2	14 / 356	14 / 356	12 / 305	7 / 178	9 / 229	6 5/8 / 168	1/2	23 / 584	28 / 13	110 / 50	50 / 23	160 / 73
3	15 / 381	15 / 381	12 1/2 / 318	8 / 203	9 / 229	6 5/8 / 168	1/2	24 / 610	28 / 13	120 / 54	50 / 23	175 / 79
4	16 / 406	16 / 406	14 / 356	8 1/4 / 210	9 1/2 / 241	8 5/8 / 219	1	21 / 533	45 / 20	147 / 67	81 / 37	219 / 99
5	16 / 406	17 1/2 / 445	15 / 381	9 1/2 / 241	11 / 279	10 3/4 / 273	1	22 / 559	45 / 20	153 / 69	81 / 37	237 / 108
6	20 / 508	21 / 533	17 / 432	9 1/2 / 241	11 / 279	10 3/4 / 273	1	24 / 610	70 / 32	203 / 92	127 / 58	328 / 149
8	22 / 559	23 / 584	21 / 533	11 / 279	12 1/2 / 318	12 3/4 / 324	1 1/2	28 / 711	110 / 50	281 / 127	184 / 83	407 / 185
10	32 / 813	33 / 838	25 / 635	13 / 330	14 1/2 / 368	16 / 406	1 1/2	33 / 838	170 / 77	450 / 204	307 / 139	710 / 322
12	35 / 889	36 / 914	28 / 711	14 1/2 / 368	16 / 406	18 / 457	1 1/2	39 / 991	209 / 95	644 / 292	390 / 177	1024 / 464
14	37 / 940	38 / 965	33 / 838	15 3/4 / 400	17 1/2 / 445	20 / 508	2	45 / 1143	272 / 123	951 / 431	492 / 223	1397 / 634
16	42 / 1067	43 / 1092	36 / 914	18 1/4 / 464	20 / 508	24 / 610	2	49 / 1245	411 / 186	1409 / 639	754 / 342	2011 / 912
18	42 / 1067	43 / 1092	39 / 991	18 1/4 / 464	20 / 508	24 / 610	2	53 / 1346	411 / 186	1486 / 674	754 / 342	2127 / 965
20	43 / 1092	44 1/2 / 1130	44 / 1118	21 3/4 / 552	24 / 610	30 / 762	2	59 / 1499	411 / 186	1553 / 704	754 / 342	2231 / 1012
24	48 / 1219	49 3/4 / 1264	60 / 1524	21 3/4 / 552	24 / 610	30 / 762	2	78 / 1981	681 / 309	2291 / 1039	1403 / 636	3497 / 1586

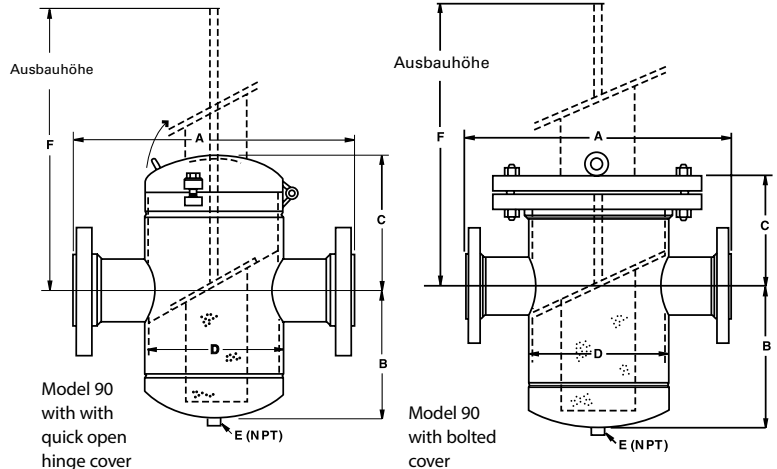
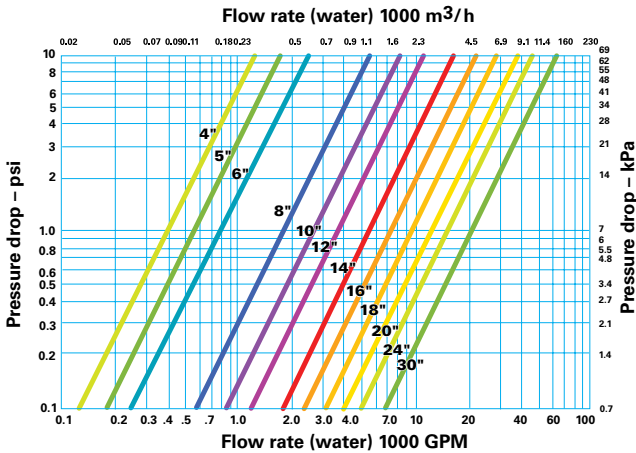

North America
44 Apple Street
Tinton Falls, NJ 07724
Toll Free: 800 656-3344
(North America only)
Tel: +1 732 212-4700

Europe/Africa/Middle East
Auf der Heide 2
53947 Nettersheim, Germany
Tel: +49 2486 809-0

Internormen Product Line
Friedensstraße 41
68804 Altlufsheim, Germany
Tel: +49 6205 2094-0

Begerow Product Line
An den Nahewiesen 24
55450 Langenlonsheim, Germany
Tel: +49 6704 204-0

China
No. 3, Lane 280,
Linhong Road
Changning District, 200335
Shanghai, P.R. China
Tel: +86 21 5200-0099

Singapore
4 Loyang Lane #04-01/02
Singapore 508914
Tel: +65 6825-1668

Brazil
Av. Julia Gaioli, 474 – Bonsucesso
07251-500 – Guarulhos, Brazil
Tel: +55 11 2465-8822

For more information, please
email us at filtration@eaton.com
or visit www.eaton.com/filtration

© 2014 Eaton. All rights reserved. All trademarks and registered trademarks are the property of their respective owners. All information and recommendations appearing in this brochure concerning the use of products described herein are based on tests believed to be reliable. However, it is the user's responsibility to determine the suitability for his own use of such products. Since the actual use by others is beyond our control, no guarantee, expressed or implied, is made by Eaton as to the effects of such use or the results to be obtained. Eaton assumes no liability arising out of the use by others of such products. Nor is the information herein to be construed as absolutely complete, since additional information may be necessary or desirable when particular or exceptional conditions or circumstances exist or because of applicable laws or government regulations.

US
EF-SSEA-19
6-2014