

NO.	PART NAME	MATERIAL
1	BODY	CARBON STEEL
2	BASKET	
	PERF. DIA	
	MESH	
3	O-RING	BUNA-N
4	COVER	CARBON STEEL
5	BOLTS	A 325
6	NUTS	A 193 B7

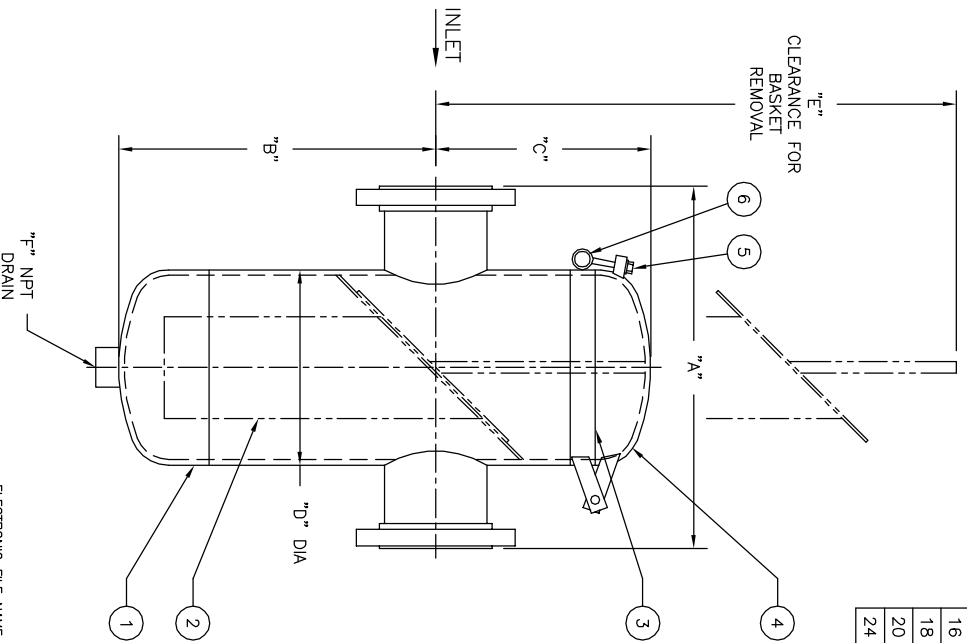

PIPE SIZE (NOMINAL)	DIMENSIONS						APPROX. WEIGHT LBS. / KG	PART NO.
	A IN. MM	B IN. MM	C IN. MM	D IN. MM	E IN. MM	F (NOM.) IN. MM		
2 (50mm)	14.00/356	12.00/305	8.63/219	6.63/168	26.00/660	1/2 (15)	71 / 32.2	ST090020BR3TA
3 (80mm)	15.00/381	12.50/318	8.63/219	6.63/168	26.00/660	1/2 (15)	90 / 40.8	ST090030BR3TA
4 (100mm)	16.00/406	14.00/356	9.50/241	8.63/219	29.00/737	1 (25)	155 / 70.3	ST090040BR3TA
5 (125mm)	16.00/406	15.00/381	11.25/286	10.75/273	33.00/838	1 (25)	205 / 93.0	ST090050BR3TA
6 (150mm)	20.00/508	17.00/432	11.25/286	10.75/273	35.00/889	1 (25)	220 / 99.8	ST090060BR3TA
8 (200mm)	22.00/559	21.00/533	13.00/330	12.75/324	42.00/1067	1-1/2 (40)	305 / 138.4	ST090080BR3TA
10 (250mm)	32.00/813	25.00/635	15.75/400	16.00/406	50.00/1270	1-1/2 (40)	500 / 226.8	ST090100BR3TA
12 (300mm)	35.00/889	28.00/711	17.75/451	18.00/457	56.00/1422	1-1/2 (40)	665 / 301.6	ST090120BR3TA
14 (350mm)	37.00/940	33.00/838	19.75/502	20.00/508	65.00/1651	2 (50)	810 / 367.4	ST090140BR3TA
16 (400mm)	42.00/1067	36.00/914	23.25/591	24.00/610	74.00/1880	2 (50)	1060 / 480.8	ST090160BR3TA
18 (450mm)	42.00/1067	39.00/991	23.25/591	24.00/610	76.00/1930	2 (50)	1110 / 503.5	ST090180BR3TA
20 (500mm)	43.00/1092	44.00/1118	27.75/705	30.00/762	88.00/2235	2 (50)	1610 / 730.3	ST090200BR3TA
24 (600mm)	48.00/1219	60.00/1524	27.75/705	30.00/762	102.00/2591	2 (50)	1900 / 861.8	ST090240BR3TA

NOTES :
 1. UNITS ARE DESIGNED IN ACCORDANCE WITH ASME SECT. VIII, DIV. 1 OF BOILER PRESSURE VESSEL. CODE & IN COMPLIANCE TO CURRENT PUBLISHED ADDENDA .
 2. CODE STAMPED VESSEL AVAILABLE.
 3. ALL DIMENSIONS ARE IN INCHES / MM.
 4. INLET / OUTLET FLANGES PER ANSI B16.5.
 5. ALL BOLT HOLES STRADDLE NATURAL CENTERLINES.
 6. DESIGN PRESSURE : 150 PSIG @ 150° F (10.3 BAR @ 65.6°C)

MDMT : -20°F @ 150 PSIG
 (MDMT : -28.9°C @ 10.3 BAR)

CERTIFIED FOR:
 P.O. NO.:
 REG. NO.:
 QUOTE NO.:
 TAG NO.:

ELECTRONIC FILE NAME: SD0900C1.DWG
 REF. ECR D507 DATE 11/1/05

UNAUTHORIZED USE, MANUFACTURE OR REPRODUCTION IN WHOLE OR IN PART IS PROHIBITED. DRAWING, DESIGN AND OTHER DISCLOSURES PROPERTY OF EATON FILTRATION, LLC

EATON		EATON FILTRATION, LLC	
900 FAIRMOUNT AVENUE, ELIZABETH, NEW JERSEY 07207			
NAME MODEL 90 BASKET STRAINER			
150# RF FLANGE / QUICK OPENING COVER			
SIZES 2" THRU 24" CARBON STEEL			
DRAWN	FM	DATE	1/5/98
SIZE	DWG NO	CERT.	LF
A			
	SD0900C1	DATE	1/5/98
		REV	B