

REVISIONS				
REV	DESCRIPTION	BY	ECO	DATE
H	UPDATED TITLE BLOCK	SBB	0533142	12/13/2023

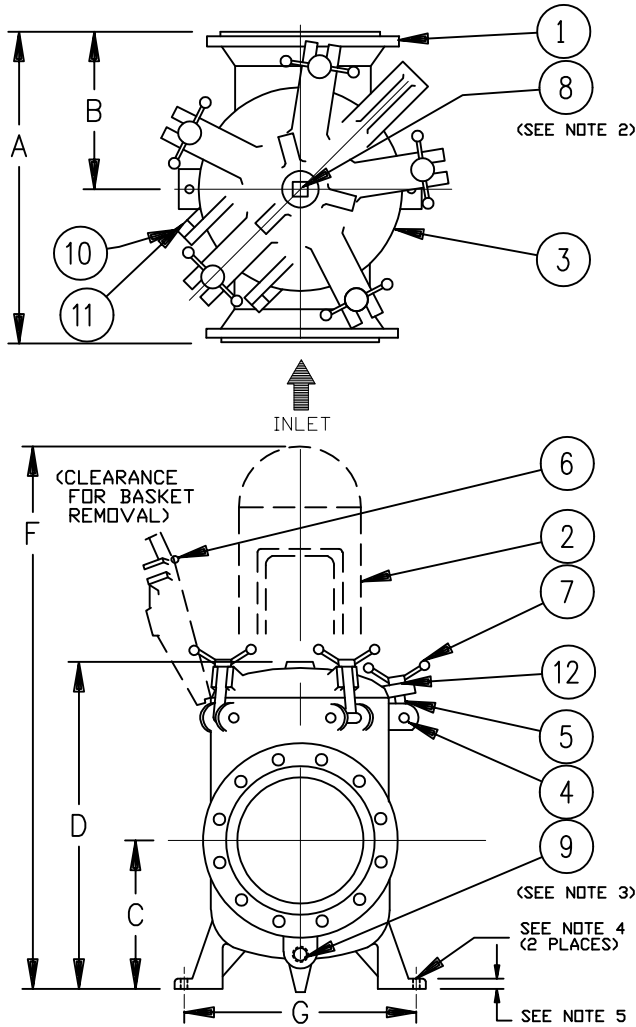

NO.	PART NAME	MATERIAL
1	BODY	DUCTILE IRON ASTM A395
2	BASKET	
	PERF. DIA.	
	MESH	
3	COVER	DUCTILE IRON ASTM A395
4	SWING NUT	CARBON STEEL
5	STUD	STEEL
6	O-RING	BUNA-N
7	HANDLE	CAST IRON
8	VENT PLUG	CARBON STEEL
9	DRAIN PLUG	CARBON STEEL
10	CLEVIS PIN	CARBON STEEL
11	COTTER PIN	STEEL
12	WASHER	STEEL

NOTES:

1. INLET/OUTLET CLASS 150 RAISED FACED FLANGED CONNECTIONS PER ASME B16.42.
2. ITEM 8, VENT - 1/4" NPT (8mm).
3. ITEM 9, DRAIN - 1-1/2" NPT (40mm).
4. MOUNTING HOLE Ø IS 1" (25mm) NOMINAL.
5. MOUNTING PAD THICKNESS 1" (25mm).
6. MAX. WORKING PRESSURE; 200 PSI @ 100° F (13.8 BAR @ 37.8° C)

PIPE SIZE (NOMINAL)	DIMENSIONS						WEIGHT (DRY)		PART NO.					
	A		B		C		D			F		G		
	IN.	MM.	IN.	MM.	IN.	MM.	IN.	MM.	IN.	MM.	IN.	MM.	LBS.	KGS.
10" (250mm)	23.00	584	11.00	279	12.19	310	29.00	737	47.00	1194	19.00	483	420	191
12" (300mm)	27.00	686	13.00	330	16.75	425	38.00	965	67.00	1702	23.00	584	550	250

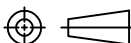
DRAWN BY VAA		 <b>EATON</b> EATON FILTRATION, LLC DESIGN CENTER CHANHASSEN, MN · GALESBURG, MI · TINTON FALLS, NJ			
SCALE AS DRAWN					
RESTRICTION RESTRICTED		TITLE MODEL 73 SIMPLEX STRAINER, 150# RAISED FACE FLANGE, SIZES 10" THRU 12" DUCTILE IRON			
SHEET 1 OF 1		DATE 05/21/92	SIZE A	DWG FILENAME SD073037	REV H
PROJECTION THIRD ANGLE 		<small>EATON CORPORATION - CONFIDENTIAL AND PROPRIETARY NOTICE TO PERSONS RECEIVING THIS DRAWING AND/OR TECHNICAL INFORMATION          THIS DOCUMENT, INCLUDING THE DRAWING AND INFORMATION CONTAINED THEREON IS CONFIDENTIAL AND IS THE EXCLUSIVE PROPERTY OF EATON AT ANY TIME. BY TAKING THE          POSSESSION OF THIS DOCUMENT THE RECIPIENT ACKNOWLEDGES AND AGREES THAT THIS DOCUMENT CANNOT BE USED IN ANY MANNER ADVERSE TO THE INTEREST OF EATON AND          THAT NO PORTION OF THIS DRAWING MAY BE COPIED OR OTHERWISE REPRODUCED WITHOUT THE PRIOR WRITTEN CONSENT OF EATON, IN THE CASE OF CONFLICTING CONTRACTUAL          PROVISIONS, THIS NOTICE SHALL GOVERN THE STATUS OF THIS DOCUMENT.          2023 EATON CORPORATION - ALL RIGHTS RESERVED.</small>			
CUSTOMER INFO					
NAME					
P.O. NO.					
TAG NO.					
S.O. NO.					
PART NO.	SEE TABLE				