

REVISIONS				
REV	DESCRIPTION	BY	ECO	DATE
B	UPDATED TITLE BLOCK	R. DHONDE	0106104	12/25/2014

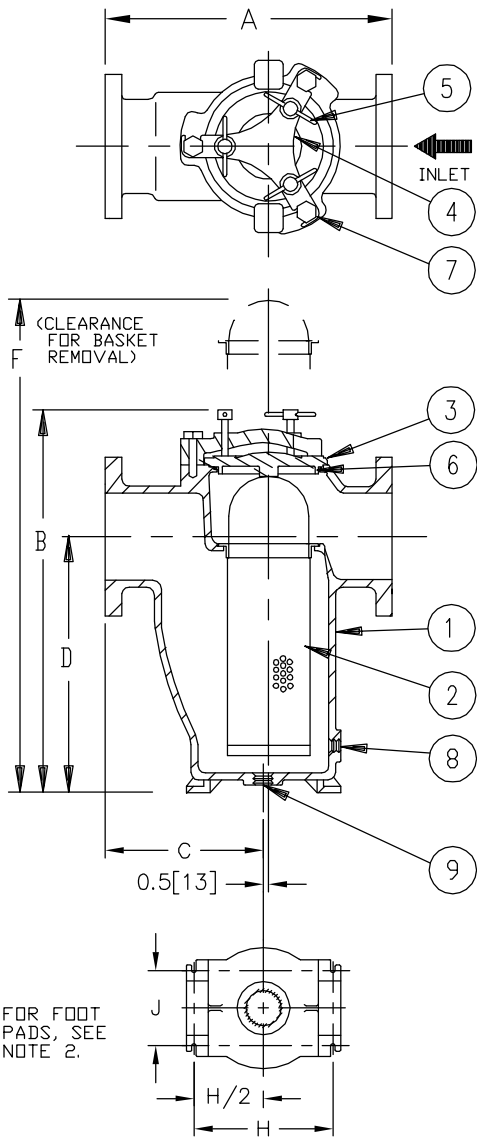

NO.	PART NAME	MATERIAL
1	BODY	CAST IRON ASTM A126 CL.B
2	SCREEN	
	PERF. DIA.	
	MESH	
3	COVER	CAST IRON ASTM A126 CL.B
4	YOKE	DUCTILE IRON
5	YOKE SCREW	STEEL
6	O-RING	BUNA-N
7	STUD	STEEL
8	DRAIN PLUG	CARBON STEEL
9	BODY PLUG	CAST IRON

- NOTES:
1. INLET/OUTLET 125 L.B. FLAT FACED FLANGED CONNECTIONS PER ASME B16.1.
 2. 5/8" DIAMETER SLOTTED FOOT PADS FOR 8" SIZE.
 3. DIMENSION "G" (NPT) IS FOR DRAIN PLUG, ITEM 8.
 4. ITEM 9, BODY PLUG IS NOT TO BE USED AS DRAIN.
 5. MAX. WORKING PRESSURE: 200 PSI @ 100° F (13.8 BAR @ 37.8° C)

PIPE SIZE (NOMINAL)	DIMENSIONS									WEIGHT (DRY) LBS. KGS.	PART NO.						
	A		B		C		D		F			G (NOM.)	H	J			
	IN.	MM.	IN.	MM.	IN.	MM.	IN.	MM.	IN.	MM.	IN.	MM.					
8" (200mm)	27.00	/ 686	40.00	/ 1016	15.50	/ 394	27.00	/ 686	60	/ 1524	1-1/2 (40)	15.75	/ 400	8.63	/ 219	500/ 227	ST0720800F4C

DRAWN BY J. JOHNSON		SCALE AS DRAWN		RESTRICTION RESTRICTED		TITLE MODEL 72 SIMPLEX STRAINER, 125# FLAT FACE FLANGE, SIZE 8" CAST IRON		DATE 10/11/13		SIZE A		DWG FILENAME SD072038		REV B	
														CUSTOMER INFO	
NAME		SHEET 1 OF 1		PROJECTION THIRD ANGLE		EATON CORPORATION - CONFIDENTIAL AND PROPRIETARY NOTICE TO PERSONS RECEIVING THIS DRAWING AND/OR TECHNICAL INFORMATION. THIS DOCUMENT, INCLUDING THE DRAWING AND INFORMATION CONTAINED THEREON IS CONFIDENTIAL AND IS THE EXCLUSIVE PROPERTY OF EATON AT ANY TIME. BY TAKING THE POSSESSION OF THIS DOCUMENT THE RECIPIENT ACKNOWLEDGES AND AGREES THAT THIS DOCUMENT CANNOT BE USED IN ANY MANNER ADVERSE TO THE INTEREST OF EATON AND THAT NO PORTION OF THIS DRAWING MAY BE COPIED OR OTHERWISE REPRODUCED WITHOUT THE PRIOR WRITTEN CONSENT OF EATON, IN THE CASE OF CONFLICTING CONTRACTUAL PROVISIONS, THIS NOTICE SHALL GOVERN THE STATUS OF THIS DOCUMENT. 2018 EATON CORPORATION - ALL RIGHTS RESERVED.		S.O. NO.		PART NO.		SEE TABLE			