

REVISIONS				
REV	DESCRIPTION	BY	ECO	DATE
F	UPDATED TITLE BLOCK	R. DHONDE	0106104	12/25/2014

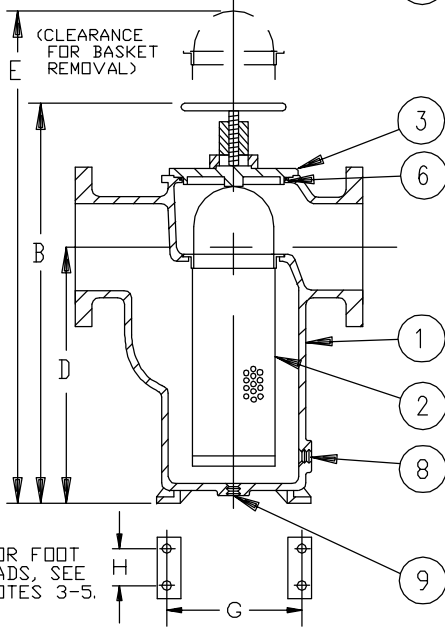
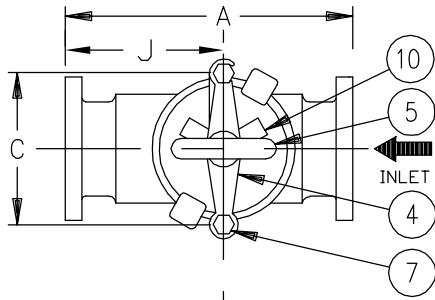

NO.	PART NAME	MATERIAL
1	BODY	BRONZE
2	SCREEN	
	PERF. DIA.	
	MESH	
3	COVER	BRONZE
4	YOKE	DUCTILE IRON
5	YOKE SCREW	STEEL
6	O-RING	BUNA-N
7	STUD	STEEL
8	DRAIN PLUG	BRONZE
9	BODY PLUG	BRONZE
10	COVER CLAMP	DUCTILE IRON

NOTES:

1. INLET/OUTLET 150 LB. FLANGED CONNECTIONS PER ASME B16.24.
2. COVER CLAMP (ITEM 10) FOR 4", 5", 6" SIZES.
3. 7/16"Ø SLOTTED FOOT PADS FOR SIZES 2", 3".
4. 1/2"Ø SLOTTED FOOT PADS FOR SIZE 2-1/2".
9/16"Ø SLOTTED FOOT PADS FOR SIZE 4"
5. 9/16"Ø HOLED FOOT PADS FOR SIZES 5", 6".
6. DIMENSION "F" (NPT) IS FOR DRAIN PLUG, ITEM 8.
7. ITEM 9, BODY PLUG IS NOT TO BE USED AS DRAIN.
8. MAX. WORKING PRESSURE : 200 PSI @ 100° F
(13.8 BAR @ 37.8° C)

PIPE SIZE (NOMINAL)	DIMENSIONS										WEIGHT (DRY)		PART NO.									
	A		B		C		D		E		F (NOM.)			G		H		J		LBS	KGS	
	IN.	MM.	IN.	MM.	IN.	MM.	IN.	MM.	IN.	MM.	IN.	MM.	IN.	MM.	IN.	MM.	IN.	MM.				
2" (50mm)	10.50/	267	13.75/	349	6.75/	171	7.63/	194	20/	508	1/2	(15)	5.50/	140	2.50/	64	6.13/	156	49	/	22	ST0720200F1C
2-1/2" (65mm)	11.63/	295	15.63/	397	8.00/	203	8.88/	226	23/	584	3/8	(10)	6.50/	165	2.88/	73	6.44/	164	64	/	29	ST0720250F1C
3" (80mm)	13.13/	334	18.00/	457	8.00/	203	10.63/	270	27/	686	3/8	(10)	7.00/	178	3.13/	80	7.12/	181	85	/	39	ST0720300F1C
4" (100mm)	16.75/	425	19.88/	505	10.69/	272	10.69/	272	29/	737	1/2	(15)	10.00/	254	3.88/	99	9.38/	238	140	/	64	ST0720400F1C
5" (125mm)	18.13/	460	25.13/	638	10.69/	272	15.19/	386	38/	965	1/2	(15)	10.00/	254	4.63/	118	10.13/	257	182	/	83	ST0720500F1C
6" (150mm)	19.63/	499	28.50/	724	10.69/	272	18.31/	465	46/	1168	1/2	(15)	10.00/	254	5.00/	127	10.81/	275	270	/	123	ST0720600F1C

DRAWN BY DM		HYDRAULICS GROUP FILTRATION DIVISION GALESBURG, MICHIGAN, USA • TINTON FALLS, NEW JERSEY, USA	
SCALE AS DRAWN			
CUSTOMER INFO		RESTRICTION RESTRICTED	TITLE MODEL 72 SIMPLEX STRAINER, 150# FLAT FACE FLANGE, SIZES 2" THRU 6" BRONZE
NAME		SHEET 1 OF 1	
P.O. NO.		PROJECTION THIRD ANGLE	DATE 08/11/97
TAG NO.			SIZE A
S.O. NO.			DWG FILENAME SD072032
PART NO.	SEE TABLE		REV F

EATON CORPORATION - CONFIDENTIAL AND PROPRIETARY NOTICE TO PERSONS RECEIVING THIS DRAWING AND/OR TECHNICAL INFORMATION
THIS DOCUMENT, INCLUDING THE DRAWING AND INFORMATION CONTAINED THEREON IS CONFIDENTIAL AND IS THE EXCLUSIVE PROPERTY OF EATON AT ANY TIME. BY TAKING THE
POSSESSION OF THIS DOCUMENT THE RECIPIENT ACKNOWLEDGES AND AGREES THAT THIS DOCUMENT CANNOT BE USED IN ANY MANNER ADVERSE TO THE INTEREST OF EATON AND
THAT NO PORTION OF THIS DRAWING MAY BE COPIED OR OTHERWISE REPRODUCED WITHOUT THE PRIOR WRITTEN CONSENT OF EATON, IN THE CASE OF CONFLICTING CONTRACTUAL
PROVISIONS, THIS NOTICE SHALL GOVERN THE STATUS OF THIS DOCUMENT.
2018 EATON CORPORATION - ALL RIGHTS RESERVED.