

REVISIONS				
REV	DESCRIPTION	BY	ECO	DATE
J	UPDATED TITLE BLOCK	R. DHONDE	0106104	12/25/2014

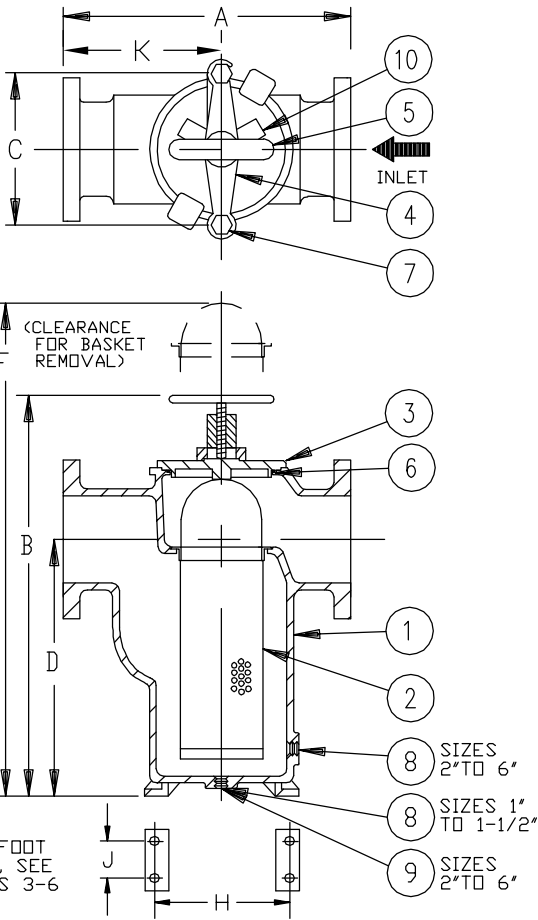

NO.	PART NAME	MATERIAL
1	BODY	CAST IRON ASTM A126 CL.B
2	SCREEN	
	PERF. DIA.	
	MESH	
3	COVER	CAST IRON ASTM A126 CL.B
4	YOKE	DUCTILE IRON
5	YOKE SCREW	STEEL
6	O-RING	BUNA-N
7	STUD	STEEL
8	DRAIN PLUG	CARBON STEEL
9	BODY PLUG	CAST IRON
10	COVER CLAMP	DUCTILE IRON

NOTES:

1. INLET/OUTLET 125 LB. FLANGED CONNECTIONS PER ASME B16.1.
2. COVER CLAMP (ITEM 10) FOR 4", 5", 6" SIZES.
3. NO FOOT PADS FOR SIZES 1", 1-1/4", 1-1/2".
4. 7/16"Ø SLOTTED FOOT PADS FOR SIZE 2".
5. 1/2"Ø SLOTTED FOOT PADS FOR SIZES 2-1/2", 3".
6. 9/16"Ø HOLED FOOT PADS FOR SIZES 4", 5", 6".
7. DIMENSIONS B, D, F ARE FROM BOTTOM OF STRAINER.
8. DIMENSION "G" (NPT) IS FOR DRAIN PLUG, ITEM 8.
9. ITEM 9, BODY PLUG IS NOT TO BE USED AS DRAIN.
10. MAX. WORKING PRESSURE : 200 PSI @ 100° F
(13.8 BAR @ 37.8° C)
11. 1 1/4" NPT STRAINER WITH CLOSE NIPPLES AND THREADED FLANGES

PIPE SIZE (NOMINAL)	DIMENSIONS										WEIGHT (DRY)		PART NO.
	A IN. MM.	B IN. MM.	C IN. MM.	D IN. MM.	F IN. MM.	G (NOM.) IN. MM.	H IN. MM.	J IN. MM.	K IN. MM.	LBS	KGS		
1" (25mm)	7.63/ 194	8.38/ 213	4.00/ 102	5.00/ 127	13/ 330	1/2 (15)	----	----	4.31/ 109	9/ 4		ST072010AF 40A	
1-1/4" (32mm)	10.25/ 260	9.88/ 251	4.88/ 124	5.88/ 149	14/ 356	1/2 (15)	----	----	5.63/ 143	13/ 6		ST072012AF 40A	
1-1/2" (40mm)	10.25/ 260	11.00/ 279	4.88/ 124	7.00/ 178	16/ 406	3/4 (20)	----	----	5.63/ 143	17/ 8		ST072015AF 40A	
2" (50mm)	10.50/ 268	13.75/ 349	6.75/ 172	7.63/ 194	20/ 508	1/2 (15)	5.50/140	2.50/ 64	6.13/ 156	37/ 17		ST0720200F 4C	
2-1/2" (65mm)	11.63/ 295	15.63/ 397	7.94/ 202	8.88/ 226	23/ 584	3/8 (10)	6.50/165	2.88/ 73	6.63/ 168	54/ 24		ST0720250F 4C	
3" (80mm)	13.13/ 334	18.00/ 457	8.00/ 203	10.88/ 276	27/ 686	3/8 (10)	7.00/178	3.13/ 80	7.13/ 181	76/ 34		ST0720300F 4C	
4" (100mm)	16.75/ 425	19.88/ 505	10.69/ 272	10.69/ 272	29/ 737	1/2 (15)	10.00/254	3.88/ 99	9.38/ 238	125/ 57		ST0720400F 4C	
5" (125mm)	18.13/ 460	25.13/ 638	10.69/ 272	15.19/ 386	38/ 965	1/2 (15)	10.00/254	4.63/118	10.13/ 257	170/ 77		ST0720500F 4C	
6" (150mm)	19.63/ 499	28.50/ 724	10.69/ 272	18.31/ 465	46/1168	1/2 (15)	10.00/254	5.00/127	10.81/ 275	200/ 91		ST0720600F 4C	

* - SEE NOTE 11

DRAWN BY VAA		 HYDRAULICS GROUP FILTRATION DIVISION GALESBURG, MICHIGAN, USA • TINTON FALLS, NEW JERSEY, USA			
SCALE AS DRAWN					
RESTRICTION RESTRICTED		TITLE MODEL 72 SIMPLEX STRAINER 125# FLAT FACE FLANGE, SIZES 1" THRU 6" CAST IRON			
SHEET 1 OF 1		DATE 11/26/91	SIZE A	DWG FILENAME SD072024	REV J
PROJECTION THIRD ANGLE		<small>EATON CORPORATION - CONFIDENTIAL AND PROPRIETARY NOTICE TO PERSONS RECEIVING THIS DRAWING AND/OR TECHNICAL INFORMATION THIS DOCUMENT, INCLUDING THE DRAWING AND INFORMATION CONTAINED THEREON IS CONFIDENTIAL AND IS THE EXCLUSIVE PROPERTY OF EATON AT ANY TIME. BY TAKING THE POSSESSION OF THIS DOCUMENT THE RECIPIENT ACKNOWLEDGES AND AGREES THAT THIS DOCUMENT CANNOT BE USED IN ANY MANNER ADVERSE TO THE INTEREST OF EATON AND THAT NO PORTION OF THIS DRAWING MAY BE COPIED OR OTHERWISE REPRODUCED WITHOUT THE PRIOR WRITTEN CONSENT OF EATON, IN THE CASE OF CONFLICTING CONTRACTUAL PROVISIONS, THIS NOTICE SHALL GOVERN THE STATUS OF THIS DOCUMENT. 2018 EATON CORPORATION - ALL RIGHTS RESERVED.</small>			
CUSTOMER INFO					
NAME					
P.O. NO.					
TAG NO.					
S.O. NO.					
PART NO.	SEE TABLE				