

REVISIONS				
REV	DESCRIPTION	BY	ECO	DATE
E	UPDATED TITLE BLOCK	R. DHONDE	0106104	12/25/2014

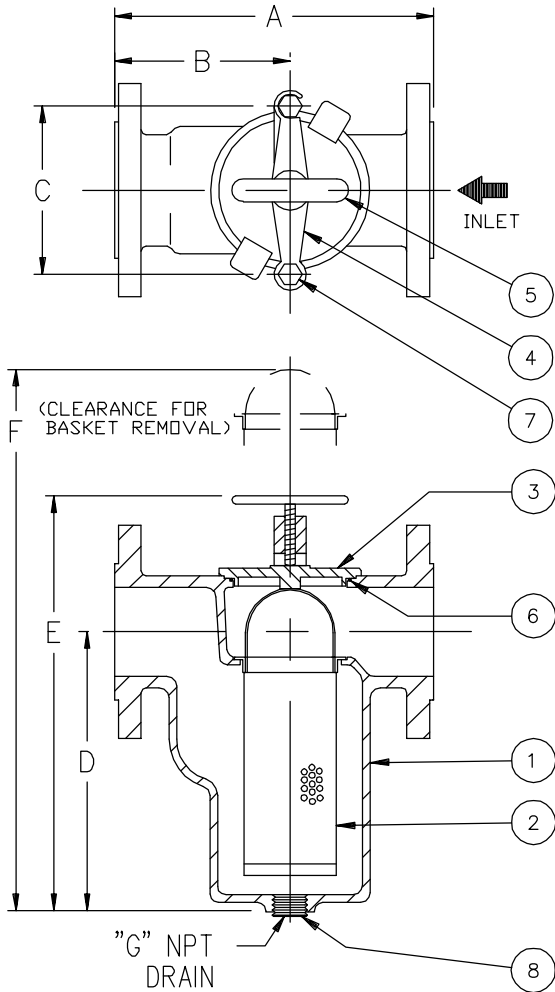

NO.	PART NAME	MATERIAL
1	BODY	CSTL ASTM A216 GR.WCB
2	SCREEN	
	PERF. DIA.	
	MESH	
3	COVER	CSTL ASTM A216 GR.WCB
4	YOKE	DUCTILE IRON
5	YOKE SCREW	STEEL
6	O-RING	BUNA-N
7	STUD	STEEL
8	PIPE PLUG	CARBON STEEL

NOTES:

1. INLET/OUTLET FLANGE CONNECTIONS PER ASME B16.5.
2. MAX. WORKING PRESSURE: 200 PSI @ 100° F (13.8 BAR @ 37.8° C)

PIPE SIZE (NOMINAL)	DIMENSIONS							WEIGHT (DRY)		PART NO.							
	A		B		C		D		E		F		G (NOM.)		LBS.	KGS.	
1" (25mm)	7.63	194	4.31	110	4.00	102	5.00	127	8.38	213	12.00	305	1/2	(15)	9	4.1	ST072010BR30A
1-1/2" (40mm)	10.25	260	5.75	146	4.88	124	7.00	178	11.00	279	16.00	406	3/4	(20)	17	7.7	ST072015BR30A

DRAWN BY FM		SCALE AS DRAWN		HYDRAULICS GROUP FILTRATION DIVISION GALESBURG, MICHIGAN, USA • TINTON FALLS, NEW JERSEY, USA							
		RESTRICTION RESTRICTED				TITLE MODEL 72 SIMPLEX STRAINER 150# RAISED FACE FLANGE, SIZES 1" & 1-1/2" CARBON STEEL					
CUSTOMER INFO		SHEET 1 OF 1		DATE 12/02/93		SIZE A		DWG FILENAME SD072021		REV E	
NAME		PROJECTION THIRD ANGLE				EATON CORPORATION - CONFIDENTIAL AND PROPRIETARY NOTICE TO PERSONS RECEIVING THIS DRAWING AND/OR TECHNICAL INFORMATION		THIS DOCUMENT, INCLUDING THE DRAWING AND INFORMATION CONTAINED THEREON IS CONFIDENTIAL AND IS THE EXCLUSIVE PROPERTY OF EATON AT ANY TIME. BY TAKING THE POSSESSION OF THIS DOCUMENT THE RECIPIENT ACKNOWLEDGES AND AGREES THAT THIS DOCUMENT CANNOT BE USED IN ANY MANNER ADVERSE TO THE INTEREST OF EATON AND THAT NO PORTION OF THIS DRAWING MAY BE COPIED OR OTHERWISE REPRODUCED WITHOUT THE PRIOR WRITTEN CONSENT OF EATON, IN THE CASE OF CONFLICTING CONTRACTUAL PROVISIONS, THIS NOTICE SHALL GOVERN THE STATUS OF THIS DOCUMENT.		2018 EATON CORPORATION - ALL RIGHTS RESERVED.	
P.O. NO.		PART NO.		SEE TABLE							