

REVISIONS				
REV	DESCRIPTION	BY	ECO	DATE
E	UPDATE TITLE BLOCK	FM	0105339	08/12/2014

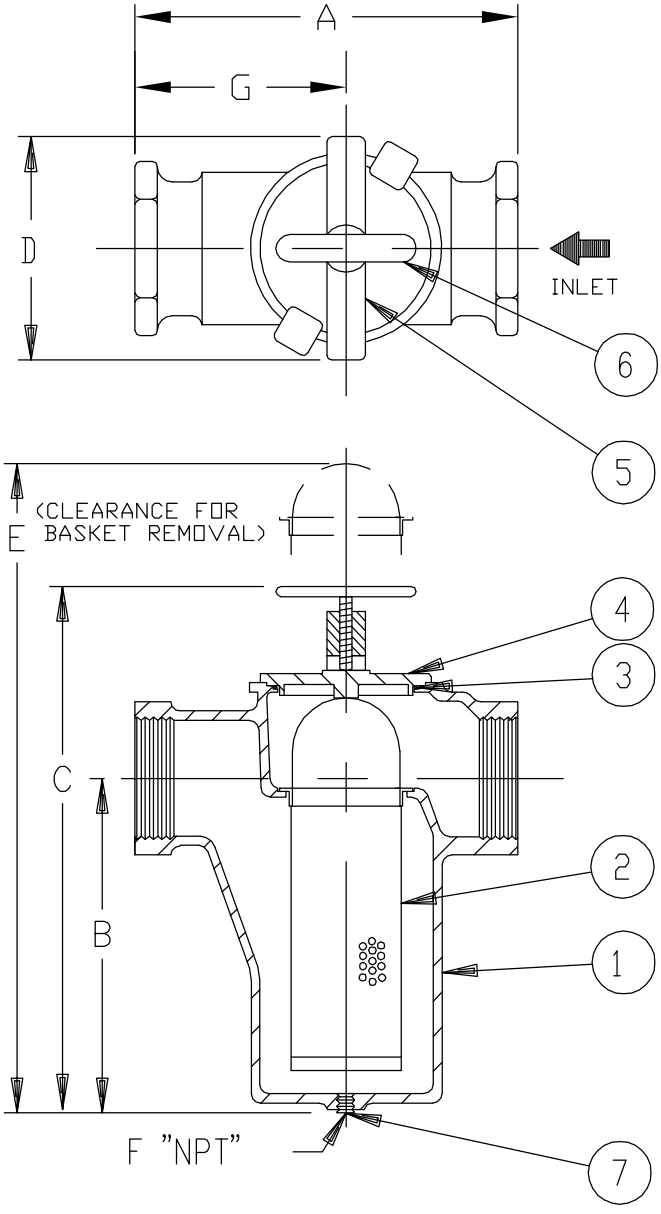

NO.	PART NAME	MATERIAL
1	BODY	CAST IRON ASTM A126 CL B
2	SCREEN	
	PERF. DIA. MESH	
3	O-RING	BUNA-N
4	COVER	CAST IRON ASTM A126 CL B
5	YOKE	DUCTILE IRON
6	YOKE SCREW	CARBON STEEL
7	DRAIN PLUG	CAST IRON ASTM A48 CL 30

- NOTES:
1. INLET/OUTLET "NPT" THREADED CONNECTIONS PER ASME B1.20.1.
 2. MAX. WORKING PRESSURE: 200 PSI @ 100° F (13.8 BAR @ 37.8° C)

PIPE SIZE (NOMINAL)	DIMENSIONS								WEIGHT (DRY)		PART NO.						
	A		B		C		D		E			F (NOM.)		G		LBS.	KGS.
	IN.	MM.	IN.	MM.	IN.	MM.	IN.	MM.	IN.	MM.	IN.	MM.	IN.	MM.			
1-1/2" (40mm)	7.00	178	6.50	165	10.63	270	6.00	152	14.88	378	3/4	(20)	3.88	99	7	3.2	ST30R015AT40A
2" (50mm)	8.50	216	7.50	191	11.63	295	7.50	191	17.38	441	1-1/4	(32)	4.81	122	20	9.1	ST30R020AT40A
2-1/2" (65mm)	11.50	292	9.13	232	15.25	387	8.00	203	22.38	568	1-1/4	(32)	6.00	152	34	15.5	ST30R025AT40A
3" (80mm)	11.50	292	9.13	232	15.25	387	8.00	203	22.63	575	1-1/4	(32)	6.00	152	34	15.5	ST30R030AT40A

DRAWN BY VAA		SCALE AS DRAWN		RESTRICTION RESTRICTED		SHEET 1 OF 1		PROJECTION THIRD ANGLE		DATE 5/8/92		SIZE A		DWG FILENAME SD30R051		REV E	
CUSTOMER INFO		NAME		P.O. NO.		TAG NO.		S.O. NO.		PART NO.		SEE TABLE		<p style="text-align: center;">EATON HYDRAULICS GROUP FILTRATION DIVISION GALESBURG, MICHIGAN, USA • TINTON FALLS, NEW JERSEY, USA</p> <p style="text-align: center;">TITLE MODEL 30R SIMPLEX STRAINER NPT CONNECTION SIZES 1-1/2" THRU 3" CAST IRON</p> <p style="text-align: center;"><small>EATON CORPORATION - CONFIDENTIAL AND PROPRIETARY NOTICE TO PERSONS RECEIVING THIS DRAWING AND/OR TECHNICAL INFORMATION THIS DOCUMENT, INCLUDING THE DRAWING AND INFORMATION CONTAINED THEREON IS CONFIDENTIAL AND IS THE EXCLUSIVE PROPERTY OF EATON AT ANY TIME. BY TAKING THE POSSESSION OF THIS DOCUMENT THE RECIPIENT ACKNOWLEDGES AND AGREES THAT THIS DOCUMENT CANNOT BE USED IN ANY MANNER ADVERSE TO THE INTEREST OF EATON AND THAT NO PORTION OF THIS DRAWING MAY BE COPIED OR OTHERWISE REPRODUCED WITHOUT THE PRIOR WRITTEN CONSENT OF EATON, IN THE CASE OF CONFLICTING CONTRACTUAL PROVISIONS, THIS NOTICE SHALL GOVERN THE STATUS OF THIS DOCUMENT. 2018 EATON CORPORATION - ALL RIGHTS RESERVED.</small></p>			