

# Permanent Media Systems



## Manual cast and fabricated pipeline strainer family

**EATON**

*Powering Business Worldwide*



Eaton's filtration business is a global leader in manufacturing filtration products that include automatic self-cleaning and fabricated pipeline strainers, mechanically cleaned filters and strainers, bag, cartridge and depth sheet filtration systems, hydraulic and lubrication oil filtration and gas/liquid separators for industrial customers worldwide. Eaton has engineering and research and development centers in the USA, Belgium, Germany and China. Sales and service centers are located in 11 countries.

Eaton supplies high-quality systems, parts and services to markets that include automotive, food and beverage, ethanol and biofuels, oil and gas, pharmaceutical, power generation, pulp and paper, chemical, paints and coatings, electronics, iron and steel manufacturing, marine and municipal and industrial water. Eaton is well positioned in key markets and is expanding its global footprint with initiatives in the Americas, EMEA and Asia Pacific.

Eaton's filtration business has led the way with technology that meets the growing and rigorous demands of vital industrial sectors. Utilizing a variety of filtration technologies, Eaton has consistently implemented the best solutions available while continually striving to make a difference for customers and the environment.

## Eaton filtration services

- State-of-the-art water testing lab facility
- Long-term or short-term equipment rental
- Field service—inspections, start-up, maintenance, repair and replacement
- Field trials
- Extensive network of manufacturer representatives and distributors worldwide
- Worldwide technical support in international markets
- Team of product specialists dedicated to providing application engineering

## Eaton technologies

- Customized and modular solutions provide a full range of retention capabilities and construction materials in manual and automated designs
- ISO 9001-2008 quality management
- Standard ASME "U," "UM" Code and CRN Stamp
- "N" stamp available
- European standards - DIN/PED
- EPA compliant solutions
- Properly sized components to meet any specified flow rate and retention requirement
- NSF approved coatings
- Ultra low discharge strainer technology that offers reduced purge volumes

## Eaton sustainability commitment

Eaton is unwavering in our commitment to being sustainable by design—in the way we operate, through the design of our products and through the energy and climate saving benefits our products deliver. Eaton issues a sustainability report as part of its annual report, available on [www.eaton.com](http://www.eaton.com).

**North America**  
44 Apple Street  
Tinton Falls, NJ 07724  
Toll Free: 800 656-3344  
(North America only)  
Tel: +1 732 212-4700

**Europe/Africa/Middle East**  
Auf der Heide 2  
53947 Nettersheim, Germany  
Tel: +49 2486 809-0

**Internormen** Product Line  
Friedensstraße 41  
68804 Altludersheim, Germany  
Tel: +49 6205 2094-0

**Begerow** Product Line  
An den Nahewiesen 24  
55450 Langenlonsheim, Germany  
Tel: +49 6704 204-0

**China**  
No. 3, Lane 280,  
Linhong Road  
Changning District, 200335  
Shanghai, P.R. China  
Tel: +86 21 5200-0099

**Singapore**  
4 Loyang Lane #04-01/02  
Singapore 508914  
Tel: +65 6825-1668

**Brazil**  
Av. Julia Gaioli, 474 – Bonsucesso  
07251-500 – Guarulhos, Brazil  
Tel: +55 11 2465-8822

For more information, please  
email us at [filtration@eaton.com](mailto:filtration@eaton.com)  
or visit [www.eaton.com/filtration](http://www.eaton.com/filtration)

© 2014 Eaton. All rights reserved. All trademarks and registered trademarks are the property of their respective owners. All information and recommendations appearing in this brochure concerning the use of products described herein are based on tests believed to be reliable. However, it is the user's responsibility to determine the suitability for his own use of such products. Since the actual use by others is beyond our control, no guarantee, expressed or implied, is made by Eaton as to the effects of such use or the results to be obtained. Eaton assumes no liability arising out of the use by others of such products. Nor is the information herein to be construed as absolutely complete, since additional information may be necessary or desirable when particular or exceptional conditions or circumstances exist or because of applicable laws or government regulations.

US  
EF-SSEA-1  
6-2014

Permanent Media Systems

# Pipeline strainer family

## Contents

### Standard cast pipeline strainers

- Cast strainers—introduction
- Model 85 Y strainer
- Model 72 simplex strainer
- Model 73 simplex straight flow strainer
- Model 72SJ simplex steam jacketed strainer
- Model 72L simplex Tefzel®-lined strainer
- Model 30R economy simplex strainer
- Model 510 multi-basket simplex strainer
- Model 53BTX ball-type duplex strainer
- Model 50 plug-type duplex strainer
- Model 52 large duplex strainer
- Model 570 multi-basket duplex strainer
- Strainer options and temporary strainers
- Basket and screen technical data

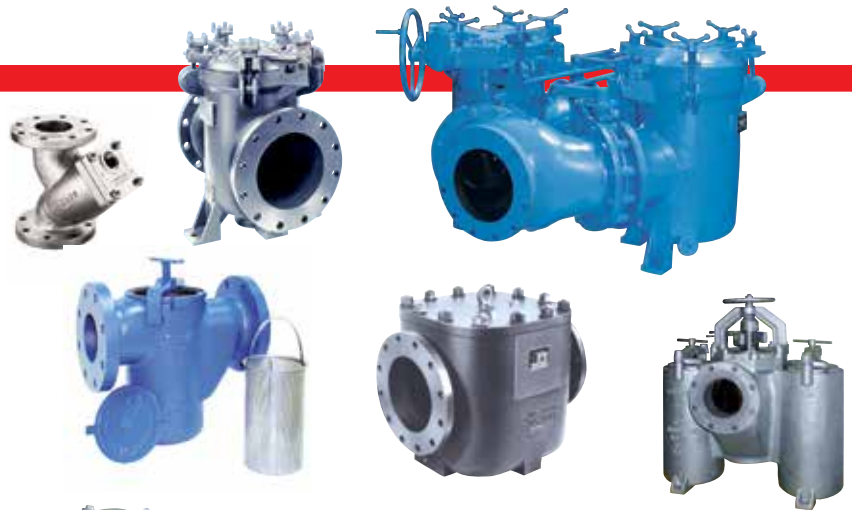

### Fabricated pipeline strainers

- Fabricated strainers—introduction
- Model 90 simplex strainer
- Model 950B duplex offset strainer
- Model 91 T-type strainer
- Fabrication options and technical data



**EATON**

*Powering Business Worldwide*



## Chemicals

The presence of a pipeline strainer means a cleaner product, protection of equipment and simple separation of solids from liquids. By installing a pipeline strainer, noticeable improvements in chemical operations and guaranteed longer running life of equipment are possible.

## Industrial and municipal water

Eaton strainers remove debris from lakes, streams and wells that can damage or clog equipment. They also remove leaves, insects, feathers, etc. From cooling tower water where the system is open to the atmosphere. For desalinization equipment, they take out unwanted matter from the water before it is treated for salt removal. Spent wastewater often passes through a basket strainer to take out material that should not go into a sewer or a waterway.

## Pharmaceuticals and cosmetics

Ointments, lotions and similar products, which may contain clumps of undispersed or undissolved matter, are pumped through strainers. In the manufacture of lipstick, for instance, unwanted lumps can ruin the product.

## Petroleum

Pipeline strainers clean unwanted material from petroleum products ranging from crude oil to gasoline. Fuel oil can contain gums, tars

or other dirt that can plug the nozzles of an oil burner. Every industrial oil burner is equipped with a strainer to screen these out. Similarly, refineries use strainers in oil handling operations to keep debris away from pumps and meters.

## Pulp and paper

Smooth paper finishes require coatings be free of pigment clumps. Strainers in the coating lines catch and retain the lumps. They also clean traces of pulp or paper from white water effluent before it is discharged.

## Process equipment

By installing a pipeline strainer ahead of expensive process equipment, the strainers protect against damage from scale, dirt or by-products, preventing costly shutdowns. Heat exchangers, condensers and pumps use strainers on their intake sides. Pipeline strainers keep flow meters and spray nozzles from clogging.

## Paint, ink and latex

Undissolved lumps of resin, skins or clumps of pigment can ruin costly coating products. They are hard to detect, yet easy to avoid when using Eaton strainers.

## Marine industry

Pipeline strainers are vital in handling seawater, which can contain a good deal of undesirable matter. Cooling lines, fire control lines, sanitary lines and general cleaning lines use strainers. Strainers also clean fuel, hydraulic and lubrication systems.

## Tank cars and trucks

A basket strainer installed on a tank truck that dispenses liquids can catch unwanted solid material. Many chemical products undergo changes during storage or transport—which result in solid residues. The presence of solids in liquid fertilizers or pesticides, for example, can cause clogging of spray equipment.

## Commercial buildings, hospitals and schools

Cooling towers and boilers use pipeline strainers to protect them from damage due to scaling.

## Food industry

Strainers remove bits of pulp, skins or other unwanted matter from fruit juices. They remove lumps from chocolate syrup and wax from honey. The baking industry strains bone and gristle from molten lard with basket strainers and uses them to remove bits of dough, seeds, etc. From discharge water. Straining water allows it to be recycled and used for other purposes.

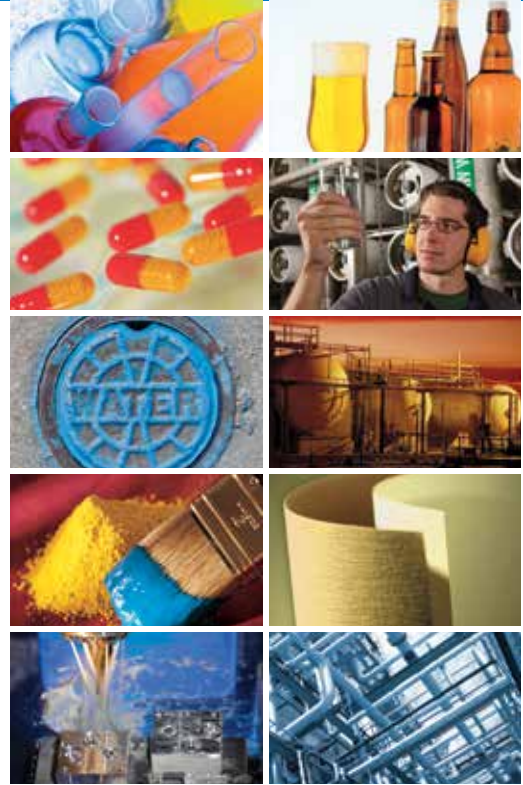

## Power generation

The electric power industry uses strainers to clean water for cooling and to protect equipment. They also strain transformer oil to avoid clogging of the circulating lines.

## More information

For specific, detailed application information, consult Eaton.

**North America**  
44 Apple Street  
Tinton Falls, NJ 07724  
Toll Free: 800 656-3344  
(North America only)  
Tel: +1 732 212-4700

**Europe/Africa/Middle East**  
Auf der Heide 2  
53947 Nettersheim, Germany  
Tel: +49 2486 809-0

**Internormen** Product Line  
Friedensstraße 41  
68804 Altlufsheim, Germany  
Tel: +49 6205 2094-0

**Begerow** Product Line  
An den Nahewiesen 24  
55450 Langenlonsheim, Germany  
Tel: +49 6704 204-0

**China**  
No. 3, Lane 280,  
Linhong Road  
Changning District, 200335  
Shanghai, P.R. China  
Tel: +86 21 5200-0099

**Singapore**  
4 Loyang Lane #04-01/02  
Singapore 508914  
Tel: +65 6825-1668

**Brazil**  
Av. Julia Gaioli, 474 – Bonsucesso  
07251-500 – Guarulhos, Brazil  
Tel: +55 11 2465-8822

**For more information, please email us at [filtration@eaton.com](mailto:filtration@eaton.com) or visit [www.eaton.com/filtration](http://www.eaton.com/filtration)**

© 2014 Eaton. All rights reserved. All trademarks and registered trademarks are the property of their respective owners. All information and recommendations appearing in this brochure concerning the use of products described herein are based on tests believed to be reliable. However, it is the user's responsibility to determine the suitability for his own use of such products. Since the actual use by others is beyond our control, no guarantee, expressed or implied, is made by Eaton as to the effects of such use or the results to be obtained. Eaton assumes no liability arising out of the use by others of such products. Nor is the information herein to be construed as absolutely complete, since additional information may be necessary or desirable when particular or exceptional conditions or circumstances exist or because of applicable laws or government regulations.

US  
EF-SSEA-2  
6-2014

Simplex, Duplex, Y-Type, Temporary, Baskets and Screens

# Standard cast pipeline strainers

## High performance systems for keeping debris out of your downstream equipment

**Eaton standard cast pipeline strainers** protect pumps, filters, nozzles, flow meters, valves, heat exchangers, condensers, oil burners, boilers and other process system components from damaging pipeline debris. Eaton maintains the largest and broadest inventory of strainers in the industry, and can provide off-the-shelf delivery of simplex, duplex and Y strainers in metals such as cast iron, carbon steel, bronze and stainless steel.



**Y strainers** function in a variety of liquid and gas steam straining applications to protect downstream process system components from damage or clogging by sand, gravel or other debris. Y strainers remove unwanted solids from liquid, gas or steam lines by means of a perforated or wire mesh element. Y strainers are cost-

effective when removing a small amount of material—resulting in long intervals between screen cleanings. To clean the strainer screen, shut down the line and remove the strainer cap. For applications with heavier dirt loading, Y strainers fitted with a "blow off" connection permits cleaning of the screen without removing it from the strainer body.

**Simplex basket strainers** are used when liquids require regular or frequent cleaning, and when the line can be shut down for short periods to clean or change the basket. Basket strainers hold substantially more material than Y strainers and offer a lower pressure drop. Installed



upright, in a horizontal line, the basket strainer lifts out from the top. This makes it easier to use with gummy or sticky fluids or with large pipeline sizes where the filled basket weight can be considerable.



**Duplex basket** strainers operate continuously so the pipeline flow never has to be shut down for strainer basket cleaning. When one basket is full, the flow shifts to the other one, making it easy to remove, clean and replace the first basket. Duplex or double basket strainers are valuable in locations in which it is impossible to shut off flow to stop the operation. Examples of these processes include cleaning fuel oil in large indus-

trial oil burners, all types of marine applications, screening water in cooling towers and straining fluids in continuously running chemical operations.

**Eaton standard cast pipeline strainers** meet customers' expectations and the highest standards, including:

- ISO 9001-2008 quality management
- Properly sized components to meet any specified retention requirement and flow rate
- NSF approved coatings
- Ultra low discharge strainer technology that offers reduced purged volumes

For more than 50 years, Eaton has led the way with designs that meet the growing and rigorous demands of process and manufacturing industries, utilities and municipalities around the world.

# EATON

Powering Business Worldwide

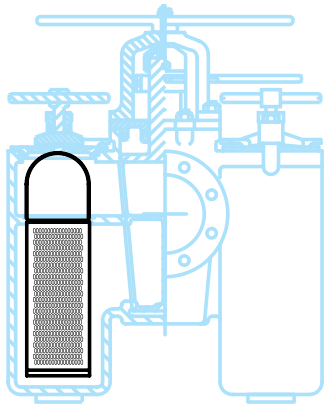

Partial cutaway of plug type duplex strainer showing basket in position

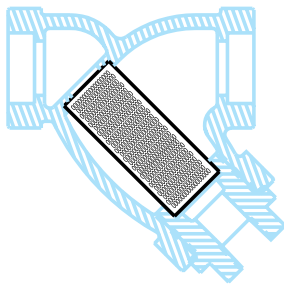

Cutaway of Y strainer shows strainer screen in position

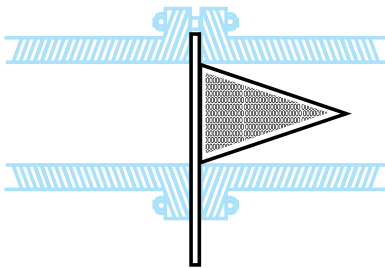

Cone type temporary strainer is shown bolted between two pipe flanges

## Basic sizing guidelines

1. Select the correct screen and opening size, do not make smaller than necessary.
2. The quantity, type and nature of debris to be removed are considered.
3. The strainer meets the design pressure and temperature requirements of the pipeline.

Strainer sizing chart

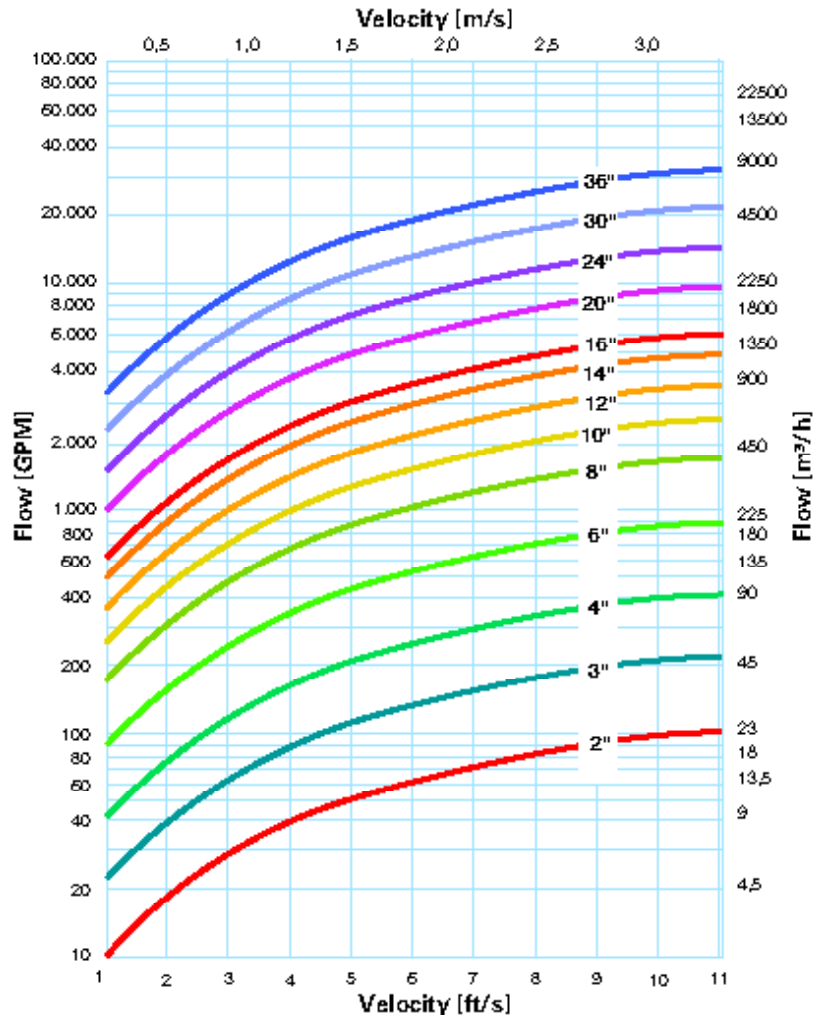

**North America**  
44 Apple Street  
Tinton Falls, NJ 07724  
Toll Free: 800 656-3344  
(North America only)  
Tel: +1 732 212-4700

**Europe/Africa/Middle East**  
Auf der Heide 2  
53947 Nettersheim, Germany  
Tel: +49 2486 809-0

**Internormen** Product Line  
Friedensstraße 41  
68804 Altludersheim, Germany  
Tel: +49 6205 2094-0

**Begerow** Product Line  
An den Nahewiesen 24  
55450 Langenlonsheim, Germany  
Tel: +49 6704 204-0

**China**  
No. 3, Lane 280,  
Linhong Road  
Changning District, 200335  
Shanghai, P.R. China  
Tel: +86 21 5200-0099

**Singapore**  
4 Loyang Lane #04-01/02  
Singapore 508914  
Tel: +65 6825-1668

**Brazil**  
Av. Julia Gaioli, 474 – Bonsucesso  
07251-500 – Guarulhos, Brazil  
Tel: +55 11 2465-8822

For more information, please  
email us at [filtration@eaton.com](mailto:filtration@eaton.com)  
or visit [www.eaton.com/filtration](http://www.eaton.com/filtration)

© 2014 Eaton. All rights reserved. All trademarks and registered trademarks are the property of their respective owners. All information and recommendations appearing in this brochure concerning the use of products described herein are based on tests believed to be reliable. However, it is the user's responsibility to determine the suitability for his own use of such products. Since the actual use by others is beyond our control, no guarantee, expressed or implied, is made by Eaton as to the effects of such use or the results to be obtained. Eaton assumes no liability arising out of the use by others of such products. Nor is the information herein to be construed as absolutely complete, since additional information may be necessary or desirable when particular or exceptional conditions or circumstances exist or because of applicable laws or government regulations.

US  
EF-SSEA-3  
6-2014



## Standard Cast Pipeline Strainers

# Options and temporary strainers



### Heavy-duty strainer baskets

For very demanding applications, heavy-duty construction baskets are extremely rugged and stand up to the most abusive conditions. Heavy-duty strainer baskets have a metal banding spot welded at top and middle to provide extra support for difficult applications.

### Magnetic inserts

In some applications, particularly where fluids are involved in machining processes, microscopic iron or steel particles may be present. These could pass through even the finest mesh screen. Magnetic inserts in the strainer basket catch these particles before they can pass through the mesh lining. Guaranteed to retain their magnetism indefinitely, the powerful Alnico magnets, completely encased and sealed in a 1/8" thick, type 316 stainless steel shell, prevent contamination or corrosion. Each magnet's capacity is 1300 gauss.



### Taps

Optimal NPT cover vent taps and inlet/outlet nozzle taps are available for most strainers.



Typical pressure differential gauge with switch.

### Differential pressure gauge

This gauge shows the pressure differential across the strainer and helps determine when to change out the strainer basket. It has a 0 - 30 psid (0 - 2.07 bar) pressure range and features a 3-1/2" gauge face. Rated at 3,000 psi (207 bar), it comes with a 1/4" NPT connection in either brass or stainless steel.

### Differential pressure gauge with switch

This standard Eaton differential pressure gauge, shown above, includes a double pole, double throw, relay contact to permit actuation of a remote electrical signaling device—such as a light on a control panel—when it reaches a predetermined differential pressure. Contact rating is 10 A/115 V/60 Hz.

### Cover vent valves

Available in brass or stainless steel, needle type valves, rated for 200 psi at 100 °F (13.8 bar at 38 °C), mount on the cover of the strainer with a 1/4" NPT tap.

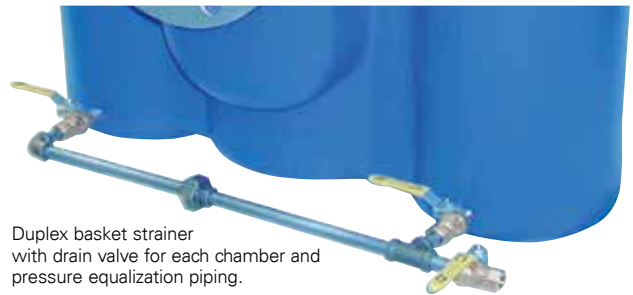

Duplex basket strainer with drain valve for each chamber and pressure equalization piping.

### Drain valves

These ball type valves, used to drain the strainer housing, are available in brass or stainless steel, rated at 600 psi at 100 °F (41.4 bar at 38 °C) with either 1/4" or 1/2" NPT connections.



### Elastomer seals

If the standard seals on a pipeline strainer are not suitable for a specific application, Eaton offers a variety of special seals that include EPDM, Viton®, Buna-N® and TFE encapsulated.

Viton® is a registered trademark of E. I. du Pont de Nemours and company. MONEL® is a registered trademark of Special Metals Corporation group of Companies.

# EATON

Powering Business Worldwide

### Basket and screen data

#### Pattern examples

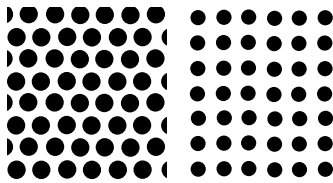

Staggered holes

Straight holes

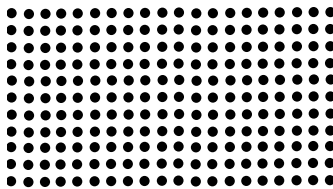

1/32" – Actual size

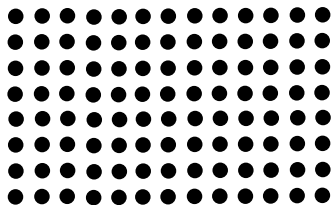

1/16" – Actual size

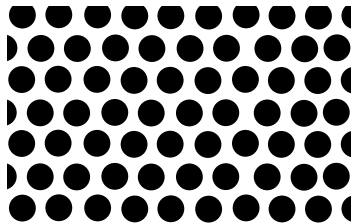

1/8" – Actual size

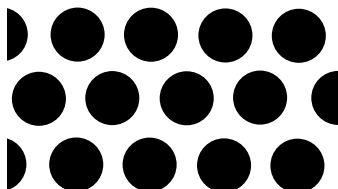

1/4" – Actual size

#### Basket and screen design

Designed to be both effective and durable, the basket or screen is the heart of an Eaton strainer. Eaton supplies baskets for simplex and duplex strainers and screens for Y strainers, in standard and heavy-duty designs. Standard design baskets meet the needs of most applications. Eaton recommends the heavy-duty design in cases when straining an extremely high viscosity material or experiencing a high solids load.

Eaton baskets and screens are available in two standard materials: 316 stainless steel or MONEL<sup>®</sup>. These materials cover nearly all corrosion resistance levels needed in strainer services. A wide range of perforations and mesh provides removal of solids from 1/2" down to as low as 40 microns. For special, unique applications, Eaton custom fabricates baskets from just about any material to exact specifications.

#### Basket construction

Each style basket includes a perforated sheet induction welded to a rigid top ring and solid bottom cap. Special attention to the welds along the perforated sheet seam, prevent the possible bypass of solids and maintain the basket's strength. A handle, welded to the I.D. of the top ring, facilitates easy removal. Heavy-duty baskets have reinforcing strips induction welded along the perforation's

seam and circumferentially on the outside of the mid-section of the basket. The perforated sheet is inside the top ring and bottom cap.

#### Screen construction

Y strainer screens, rolled to form a cylinder, are induction welded along the seam. A neat weld, applied along the perforated sheet seam, prevents the possible bypass of solids and provides a seam of acceptable strength. Eaton machines Y strainer screen seats to specific dimensions and, accordingly, both the O.D. and length of these screens are closely toleranced.

#### Perforated sheet – specification

Eaton baskets utilize perforated sheets because of their greater inherent strength and resistance to stress cracking. The percentage of open area of a screen generally dictates the internal pressure drop experienced across it. The objective is to select a perforation with the best balance of open area, hole arrangement and sheet thickness.

#### Open area

Perforated sheets can have an open area from 15% to 75%. In general, the larger the open area of perforated sheet, the thinner the sheet thickness must be. Holes punched closer together increase the perforated open area; the solid portion between holes distorts and becomes weak. Another

factor in controlling the sheet thickness is the hole diameter. The smaller the hole diameter, the thinner the sheet. Eaton baskets and screens have between 28% to 63% open area with gauge thickness from 18 (0.048 mm) to 25 (0.021 mm), depending upon the size of the perforations and the size and model of the strainer.

#### Hole arrangement

Holes can be punched either in a straight line or in a staggered pattern. Eaton baskets and screens have a staggered pattern that increases the open area, provides extra strength and creates less pressure drop.

#### Perforations

Eaton baskets and screens are available in 1/32", 3/64", 1/16", 1/8", 5/32", 1/4", 3/8" and 1/2" perforations and in mesh sizes 20, 40, 60, 80, 100, 200, 325 and 400. However, for general service there is one perforation for each size and type of strainer. Unless specified, this standard perforation is the size furnished with the strainer.

MONEL<sup>®</sup> is a registered trademark of Special Metals Corporation group of Companies.



Powering Business Worldwide



### Basket and screen data

#### Wire mesh specifications

Eaton strainers are available with woven wire mesh screens. Wire mesh provides smaller openings for very fine straining applications down to 40 microns. Eaton baskets and screens use monofilament mesh possessing equal wire size and wire count in both directions to produce square openings. Other types of mesh such as Dutch (or Hollander) are also available. Dutch weave has a greater quantity of wires in one direction and fewer wires of a larger diameter in the other direction. This creates a rectangular opening. As with perforated sheet, the best wire mesh selection is a balance of open area, wire diameter and type of weave.

#### Openings

Standard wire mesh liners for Eaton baskets and screens are available from 20 to 400 mesh. For any size mesh, there are different open area selections based on the diameter of the wires used. Twenty mesh means 20 wires per inch in both a vertical and horizontal direction. Therefore, as the wire size increases, the hole size decreases. Eaton baskets offer wire mesh with openings from 0.034" to 0.0015" (20 mesh to 400 mesh).

#### Open area

The open area of wire mesh is a function of both the weave and the wire diameter. Eaton uses a plain square weave in most cases because its straight-through flow path creates the least pressure drop. The mesh is

reinforced with a perforated metal backing possessing greater than a 60% open area. This combination affords the greatest degree of strength, yet offers a lower pressure drop than other types of wire mesh. In certain instances, such as Y strainer in steam applications, the increased pressure drop resulting from the use of a Dutch weave is not as critical as the retention of small particles. Therefore, in applications that involve steam, Eaton suggests the use of weave such as the 30 x 160 size that can withstand a much higher differential pressure without bursting. Eaton can supply baskets and screens with open areas from 14% to 46%

#### Plain square weave

Woven in an over and under pattern of wire having the same diameter, this weave produces a square opening with excellent flow characteristics.

#### Plain dutch weave

Woven in an over and under pattern in one direction in which the horizontal wires are larger in diameter than the vertical wires, which are driven close and crimped at each pass. This weave produces greater strength, but lower flow rates, than a square weave. Most often used in steam applications.

#### Mesh liners available

The number of openings per linear inch determines the size of mesh liners. The standard sizes Eaton can furnish are 20, 40, 60, 80, 100, 200, 325 and 400.

#### Perforated basket sheet specifications

Perforation size inches	Sheet thickness uss gauge #	Hole pattern	% Open area
0.020	26 (0.018 mm)	Straight	16.0
1/32	26 (0.018 mm)	Straight	28.0
3/64	26 (0.018 mm)	Straight	30.2
0.045	26 (0.018 mm)	Straight	37.0
1/16	26 (0.018 mm)	Straight	31.0
1/8	26 (0.018 mm)	Staggered	40.0
5/32	26 (0.018 mm)	Staggered	63.0
1/4	26 (0.018 mm)	Staggered	42.0
3/8	26 (0.018 mm)	Staggered	52.0
1/2	26 (0.018 mm)	Staggered	47.9

#### Mesh basket sheet specifications

Mesh size	Wire diameter inches	Mesh opening inches	Mesh opening microns	% Open area
20	0.016	0.0340	864	46.2
40	0.010	0.0150	381	36.0
60	0.0075	0.0092	234	30.5
80	0.0060	0.0065	165	27.0
100	0.0045	0.0055	140	30.3
200	0.0021	0.0029	74	33.6
325	0.0014	0.0017	43	30.0
400	0.0010	0.0015	38	36.0

#### Wire mesh weaves

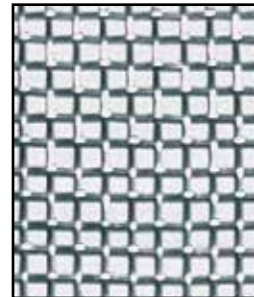

Plain square weave

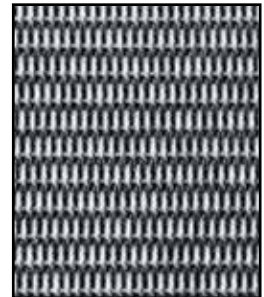

Plain dutch weave

**North America**  
44 Apple Street  
Tinton Falls, NJ 07724  
Toll Free: 800 656-3344  
(North America only)  
Tel: +1 732 212-4700

**Europe/Africa/Middle East**  
Auf der Heide 2  
53947 Nettersheim, Germany  
Tel: +49 2486 809-0

**Internormen** Product Line  
Friedensstraße 41  
68804 Altludersheim, Germany  
Tel: +49 6205 2094-0

**Begerow** Product Line  
An den Nahewiesen 24  
55450 Langenlonsheim, Germany  
Tel: +49 6704 204-0

**China**  
No. 3, Lane 280,  
Linhong Road  
Changning District, 200335  
Shanghai, P.R. China  
Tel: +86 21 5200-0099

**Singapore**  
4 Loyang Lane #04-01/02  
Singapore 508914  
Tel: +65 6825-1668

**Brazil**  
Av. Julia Gaioli, 474 – Bonsucesso  
07251-500 – Guarulhos, Brazil  
Tel: +55 11 2465-8822

For more information, please email us at [filtration@eaton.com](mailto:filtration@eaton.com) or visit [www.eaton.com/filtration](http://www.eaton.com/filtration)

© 2014 Eaton. All rights reserved. All trademarks and registered trademarks are the property of their respective owners. All information and recommendations appearing in this brochure concerning the use of products described herein are based on tests believed to be reliable. However, it is the user's responsibility to determine the suitability for his own use of such products. Since the actual use by others is beyond our control, no guarantee, expressed or implied, is made by Eaton as to the effects of such use or the results to be obtained. Eaton assumes no liability arising out of the use by others of such products. Nor is the information herein to be construed as absolutely complete, since additional information may be necessary or desirable when particular or exceptional conditions or circumstances exist or because of applicable laws or government regulations.

US  
EF-SSEA-16  
6-2014

# TECHNICAL INFORMATION

## Standard Cast Pipeline Strainers

### Basket effective area

Strainer model	Pipe size (in)	Perforation size (in)	Nominal area of pipe (sq in)	Gross screen area (sq in)	Free area (sq in)	Ratio free area to pipe area
85	1/4	.045	.10	5.0	1.8	18.0
85	3/8	.045	.19	5.0	1.8	9.5
85	1/2	.045	.30	5.0	1.8	6.0
85	3/4	.045	.53	7.1	2.6	4.9
85	1	.045	.86	10.4	3.7	4.3
85	1-1/4	.045	1.49	15.1	5.5	3.7
85	1-1/2	.045	2.03	21.7	7.8	3.8
85	2	.045	3.35	30.4	10.9	3.3
85	2-1/2	.045	4.78	43.2	15.5	3.2
85	3	.045	7.39	70.7	25.5	3.4
85	4	.045	12.73	106.8	38.4	3.0
85	6	.045	28.70	241.7	87.0	3.0
85	8	.045	50.02	414.6	149.2	3.0
85	10	.045	71.80	652.2	234.8	3.3
30R	1-1/2	5/32	2.03	35.4	22.3	11.0
30R	2	5/32	3.35	50.9	32.1	9.6
30R	2-1/2	5/32	4.78	84.7	53.4	11.2
30R	3	5/32	7.39	84.7	53.4	7.2
30R	4	5/32	12.73	114.5	72.1	5.6
30R	5	5/32	20.0	158.1	99.6	5.0
30R	6	5/32	28.9	180.9	113.9	4.0
30R	8	5/32	50.03	275.6	171.8	3.4
50	5	3/16	20.0	216.1	106.0	5.4
50	6	3/16	28.9	265.4	132.7	4.6
50	8	3/16	50.02	506.7	253.4	5.1
52	10	3/16	78.8	800	400	5.1
52	12	3/16	113.1	1200	600	5.3
52	14	3/16	137.9	2000	1000	7.3
52	16	3/16	182.6	2000	1000	5.5
52	18	3/16	182.6	2000	1000	5.5
53BTX	3/4	1/32	0.53	19.8	5.5	10.4
53BTX	1	1/32	0.86	19.8	5.5	6.4
53BTX	1-1/4	1/8	1.49	45.0	22.0	14.4
53BTX	1-1/2	1/8	2.03	45.0	22.0	10.6
53BTX	2	1/8	3.35	65.0	31.0	9.3
53BTX	2-1/2	1/8	4.78	65.0	31.0	6.5
53BTX	3	3/16	7.39	110.3	55.1	7.4
53BTX	4	3/16	12.73	152.0	76.0	5.9

Strainer model	Pipe size (in)	Perforation size (in)	Nominal area of pipe (sq in)	Gross screen area (sq in)	Free area (sq in)	Ratio free area to pipe area
72	3/8	1/32	0.19	12.7	3.4	18.0
72	1/2	1/32	0.30	12.7	3.4	11.3
72	3/4	1/32	0.53	19.5	5.2	9.9
72	1	1/32	0.86	19.5	5.2	6.1
72	1-1/4	1/8	1.49	30.1	14.4	9.7
72	1-1/2	1/8	2.03	49.7	19.0	9.4
72	2	1/8	3.35	50.9	24.4	7.3
72	2-1/2	1/8	4.78	80.2	38.4	8.0
72	3	3/16	7.39	114.5	57.2	7.8
72	4	3/16	12.73	168.3	84.1	6.6
72	5	3/16	20.0	265.4	132.7	6.6
72	6	3/16	28.9	324.2	162.1	5.6
72	8	3/16	50.02	555.3	277.7	5.6
73	10	3/16	78.8	800	400	5.1
73	12	3/16	113.1	1200	600	5.3
73	14	3/16	137.9	2000	1000	7.3
73	16	3/16	182.6	2000	1000	5.5
73	18	3/16	182.6	2000	1000	5.5

## Alloy data

### Metal alloys used in Eaton strainers

#### Carbon steel – ASTM A-216 grade WCB

Tensile strength: . . . . . 70,000 lb/sq  
(480 N/mm<sup>2</sup>)  
Yield: . . . . . 36,000 lb/sq in (245 N/mm<sup>2</sup>)  
Elongation: . . . . . 22%  
Chemical composition:  
C (Carbon) . . . . . 0.30%  
Si (Silicon) . . . . . 0.60%  
P (Phosphorus) . . . . . 0.04%  
S (Sulfur) . . . . . 0.045%  
Mn (Manganese) . . . . . 1.00%  
Residual Elements . . . . . 1.00% max

#### Aluminum bronze – ASTM B-148 grade C95400

Tensile strength: . . . . . 75,000 lb/sq in  
(517 N/mm<sup>2</sup>)  
Yield: . . . . . 30,000 lb/sq in (206 N/mm<sup>2</sup>)  
Elongation: . . . . . 12%  
Chemical composition:  
Cu (Copper) . . . . . 85%  
Fe (Iron) . . . . . 4%  
Al (Aluminum) . . . . . 11%

#### Stainless steel – ASTM A-351 grade CF8M

Tensile strength: . . . . . 70,000 lb/sq in  
(480 N/mm<sup>2</sup>)  
Yield: . . . . . 30,000 lb/sq in (206 N/mm<sup>2</sup>)  
Elongation: . . . . . 30%  
Chemical composition:  
C (Carbon) . . . . . 0.08% max  
Si (Silicon) . . . . . 1.5%  
P (Phosphorus) . . . . . 0.040%  
Cr (Chromium) . . . . . 18.0 - 21.0%  
Ni (Nickel) . . . . . 9.0 - 12.0%  
Mn (Manganese) . . . . . 1.50%  
S (Sulfur) . . . . . 0.04%  
Mo (Molybdenum) . . . . . 2.0 - 3.0%

#### Cast iron – ASTM A-126 class B

Tensile strength: . . . . . 31,000 lb/sq in  
(214 N/mm<sup>2</sup>)  
Compressive strength: . . . . . 109,000 lb/sq in  
(750 N/mm<sup>2</sup>)  
Tensile modulus: . . . . . 15 x 10<sup>6</sup> lb/sq in  
Chemical composition:  
C (Carbon) . . . . . 3.20 - 3.40 %  
Si (Silicon) . . . . . 2.10 - 2.30%  
P (Phosphorus) . . . . . 0.15 - 0.30%  
S (Sulfur) . . . . . 0.08 - 0.12%  
Mn (Manganese) . . . . . 0.50 - 0.80%

#### Ductile iron – ASTM A-395 grade 60-40-18

Tensile strength: . . . . . 60,000 lb/sq in  
(413 N/mm<sup>2</sup>)  
Yield: . . . . . 40,000 lb/sq in  
(275 N/mm<sup>2</sup>)  
Elongation: . . . . . 18%  
Chemical composition:  
C (Carbon) . . . . . 3.20 - 4.0%  
Si (Silicon) . . . . . 1.80 - 2.80%  
P (Phosphorus) . . . . . 0.08% max.  
S (Sulfur) . . . . . 0.03% max.  
Mn (Manganese) . . . . . 0.03% max.

# TECHNICAL INFORMATION

## Standard Cast Pipeline Strainers

### Pressure drop calculations

Pressure drops for Eaton strainers are shown on each product page. The curves are based on the flow of water through clean, perforated baskets or screens. For mesh-lined baskets or screens and/or for fluids other than water, use the correction factors listed on this page. To accurately calculate the pressure loss for filters and strainers in a pipeline, proceed as follows:

1. First calculate pressure loss using  $C_V$  factor formula at right.
2. Take the pressure loss figure obtained in (1) and recalculate it using the appropriate correction factor from the following table.

#### Correction factors for mesh-lined baskets

**First** – Multiply the pressure drop for water shown in charts by the specific gravity of the liquid.

**Second** – Multiply the corrected pressure drop figure by the following correction factors for more viscous liquids. (Water has a viscosity of 30 SSU.)

Viscosity (SSU)	Unlined perforated basket	40 Mesh lined basket	60 Mesh lined basket	80 Mesh lined basket	100 Mesh lined basket	200 Mesh lined basket	325 Mesh lined basket
30 (water)	1	1.2	1.4	1.6	1.7	2.0	2.5
500	1.6	1.9	2.1	2.4	2.6	3.1	3.6
1000	1.7	2.2	2.4	2.6	2.8	3.3	3.8
2000	1.9	2.4	2.7	2.9	3.2	3.8	4.0
3000	2.0	2.6	2.9	3.2	3.5	4.1	4.3
5000	2.2	3.0	3.5	4.0	4.5	5.3	6.3
10000	2.5	3.5	4.2	5.0	6.0	7.1	8.5

#### Strainer basket opening equivalents

Mesh	Inches	Millimeters	Microns	Perf	Inches	Millimeters	Microns
400	0.0015	0.0381	38	1/32	0.033	0.838	838
300	0.0018	0.0457	45	3/64	0.045	1.143	1143
250	0.0024	0.0609	60	1/16	0.070	1.778	1776
200	0.0027	0.0686	68	3/32	0.094	2.387	2387
150	0.0041	0.1041	104	1/8	0.125	3.175	3175
100	0.0065	0.1651	165	5/32	0.150	3.810	3810
80	0.007	0.1778	177	3/16	0.1875	4.762	4762
60	0.009	0.2286	228	1/4	0.250	6.350	6350
40	0.015	0.8636	380	3/8	0.375	9.525	9525
20	0.034	0.8636	862	1/2	0.500	12.700	12700

**North America**  
44 Apple Street  
Tinton Falls, NJ 07724  
Toll Free: 800 656-3344  
(North America only)  
Tel: +1 732 212-4700

**Europe/Africa/Middle East**  
Auf der Heide 2  
53947 Nettersheim, Germany  
Tel: +49 2486 809-0

**Internormen** Product Line  
Friedensstraße 41  
68804 Altlußheim, Germany  
Tel: +49 6205 2094-0

**Begerow** Product Line  
An den Nahewiesen 24  
55450 Langenlonsheim, Germany  
Tel: +49 6704 204-0

**China**  
No. 3, Lane 280,  
Linhong Road  
Changning District, 200335  
Shanghai, P.R. China  
Tel: +86 21 5200-0099

**Singapore**  
4 Loyang Lane #04-01/02  
Singapore 508914  
Tel: +65 6825-1668

**Brazil**  
Av. Julia Gaioli, 474 – Bonsucesso  
07251-500 – Guarulhos, Brazil  
Tel: +55 11 2465-8822

#### Pressure loss calculation using $C_V$ factor

##### Metric units

$$\Delta p = \left[ \frac{Q}{C_V} \right]^2 (133.6)$$

$\Delta p$  = Pressure drop in kPa

$Q$  = Flow in m<sup>3</sup>/h

$C_V$  = Flow coefficient

##### Standard units

$$\Delta p = \left[ \frac{Q}{C_V} \right]^2$$

$\Delta p$  = Pressure drop in psi

$Q$  = Flow in gpm

$C_V$  = Flow coefficient

The pressure loss across a strainer can be calculated using the system's flow rate and the  $C_V$  factor for that strainer.

For example, a 1" Model 72 simplex strainer with a perforated basket has a  $C_V$  factor of 22.5. In water service with a 30 gpm (6.8 m<sup>3</sup>/h) flow rate, it will have a 1.7 psi (117 mbar) pressure drop  $(30 \div 22.5)^2 = 1.7$ . For mesh-lined baskets and/or fluids with a viscosity greater than water, multiply the pressure drop by the correction factors in the chart "Correction factors for mesh-lined baskets."

For more information, please email us at [filtration@eaton.com](mailto:filtration@eaton.com) or visit [www.eaton.com/filtration](http://www.eaton.com/filtration)

© 2014 Eaton. All rights reserved. All trademarks and registered trademarks are the property of their respective owners. All information and recommendations appearing in this brochure concerning the use of products described herein are based on tests believed to be reliable. However, it is the user's responsibility to determine the suitability for his own use of such products. Since the actual use by others is beyond our control, no guarantee, expressed or implied, is made by Eaton as to the effects of such use or the results to be obtained. Eaton assumes no liability arising out of the use by others of such products. Nor is the information herein to be construed as absolutely complete, since additional information may be necessary or desirable when particular or exceptional conditions or circumstances exist or because of applicable laws or government regulations.

US  
EF-SSEA-17  
6-2014



Simplex, Duplex, T-Type

# Custom fabricated strainers

## Modular systems make it easy to meet precise specifications

### Nothing too big, too small or too special

Eaton custom fabricated pipeline strainers are unique designs that fit the exact requirements of any application. Whether it is a special alloy, unique piping connection, or cover opening system, or even an extraordinary size, Eaton's talented engineers will design and develop strainers to any specification.

With extensive manufacturing capabilities and investment in equipment, all but the most specialized fabrication work is performed in-house—reducing costs and expediting delivery of finished strainers. All equipment is manufactured to customer specifications with full consideration to meet required delivery dates.

Eaton prides itself on innovation and continually invests in new products and technology.

Known for quality workmanship, Eaton fabricated pipeline strainers meet customers' expectations and the highest standards, including:

- ISO 9001-2008 quality management
- Standard ASME "U" and "UM" Code Stamp
- "N" stamp available
- Brazilian NR-13 available
- European standards - DIN/PED available
- Properly sized components to meet any specified flow rate and retention requirement
- NSF approved coatings
- Ultra low discharge strainer technology that offers reduced purged volumes



Model 91 T-type strainer with Quick Open Cover



24" simplex Model 90 low profile carbon steel fabricated strainer

Eaton's continued success can be attributed to the amount of skill and pride that goes into the production of each customers' fabricated pipeline strainer.

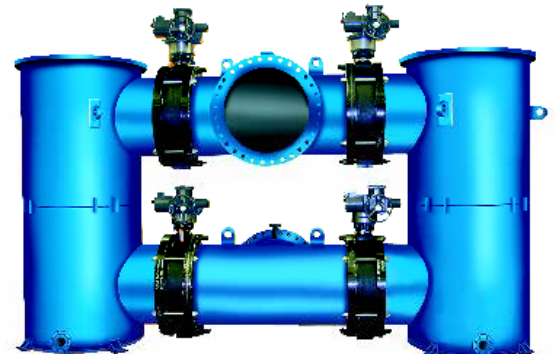

Model 950B fabricated carbon steel duplex strainer



Powering Business Worldwide

Viton® is a registered trademark of E. I. du Pont de Nemours and company.



12" Model 950B duplex strainer with quick open cover

## Basic sizing guidelines

1. Select the correct screen and opening size, do not make smaller than necessary.
2. The quantity, type and nature of debris to be removed are considered.
3. The strainer meets the design pressure and temperature requirements of the pipeline.

Strainer sizing chart

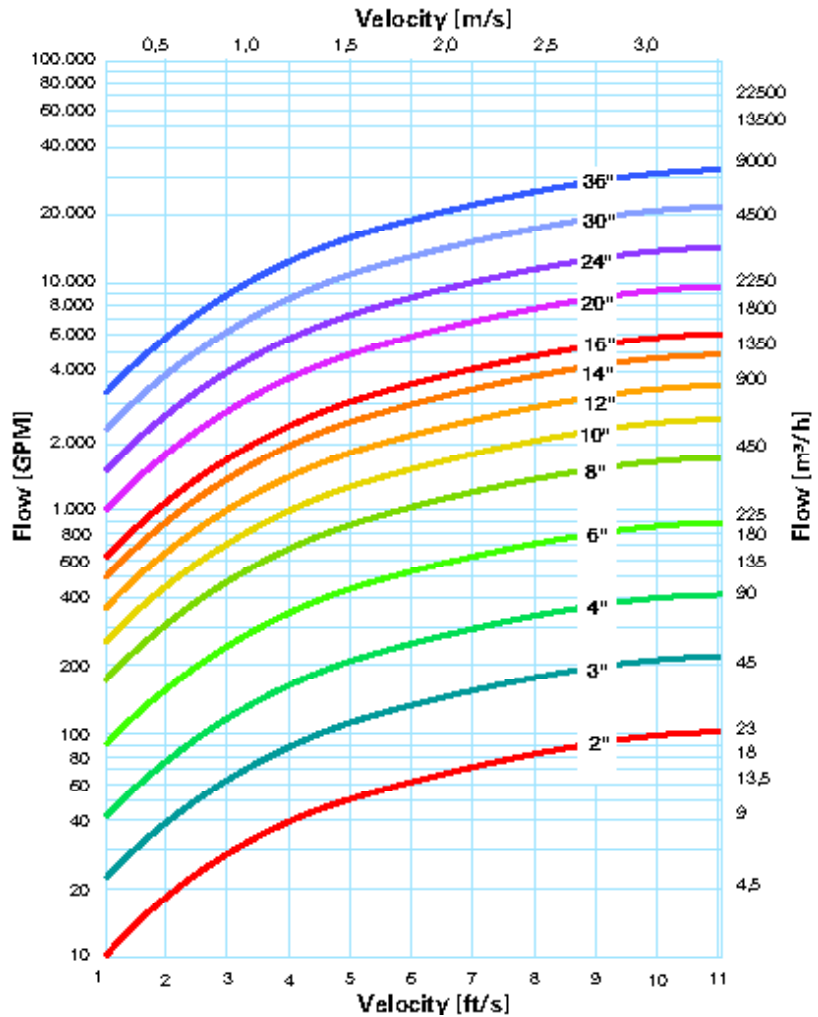

### Fabrication options

- Simplex, duplex and T-type fabrication
- Pipe sizes 2" to 60"
- ANSI class flanges from 150# to 1500# or DIN EN
- Bolted, quick opening hinged cover or davit assembly
- Carbon steel, stainless steel or special alloy construction for body and baskets
- RTJ-style connections
- Vent valves
- Drain valves
- Gauge taps
- Pressure differential gauge and switches
- Backflushing system for manual or automated cleaning
- Steam jacket for highly viscous fluids
- Custom nozzle positioning including rotated or offset placement
- High pressure/temperature capabilities
- Construction according to "AD 2000-Merkblätter", DIN EN 13445 or ASME Code
- Perforated baskets from 1/32" to 1" hole diameter
- Mesh basket liners from 20 to 400 (862 to 38 microns)
- Viton®, Buna-N® or other O-ring seal material
- Coatings and linings available upon request

**North America**  
44 Apple Street  
Tinton Falls, NJ 07724  
Toll Free: 800 656-3344  
(North America only)  
Tel: +1 732 212-4700

**Europe/Africa/Middle East**  
Auf der Heide 2  
53947 Nettersheim, Germany  
Tel: +49 2486 809-0

**Internormen** Product Line  
Friedensstraße 41  
68804 Altlufsheim, Germany  
Tel: +49 6205 2094-0

**Begerow** Product Line  
An den Nahewiesen 24  
55450 Langenlonsheim, Germany  
Tel: +49 6704 204-0

**China**  
No. 3, Lane 280,  
Linhong Road  
Changning District, 200335  
Shanghai, P.R. China  
Tel: +86 21 5200-0099

**Singapore**  
4 Loyang Lane #04-01/02  
Singapore 508914  
Tel: +65 6825-1668

**Brazil**  
Av. Julia Gaioli, 474 – Bonsucesso  
07251-500 – Guarulhos, Brazil  
Tel: +55 11 2465-8822

For more information, please  
email us at [filtration@eaton.com](mailto:filtration@eaton.com)  
or visit [www.eaton.com/filtration](http://www.eaton.com/filtration)

© 2014 Eaton. All rights reserved. All trademarks and registered trademarks are the property of their respective owners. All information and recommendations appearing in this brochure concerning the use of products described herein are based on tests believed to be reliable. However, it is the user's responsibility to determine the suitability for his own use of such products. Since the actual use by others is beyond our control, no guarantee, expressed or implied, is made by Eaton as to the effects of such use or the results to be obtained. Eaton assumes no liability arising out of the use by others of such products. Nor is the information herein to be construed as absolutely complete, since additional information may be necessary or desirable when particular or exceptional conditions or circumstances exist or because of applicable laws or government regulations.

US  
EF-SSEA-18  
6-2014

# TECHNICAL INFORMATION

## Fabricated Pipeline Strainers

### Configuration options

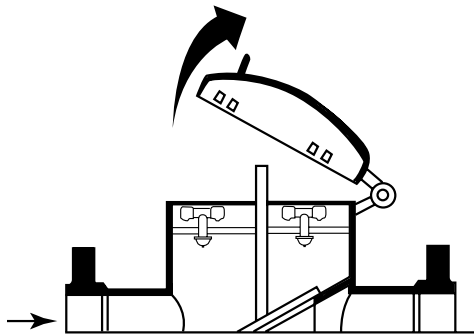

**Quick open hinged cover**

The hinged cover in medium size ranges (8"-16") permits a single operator to open and close the cover.

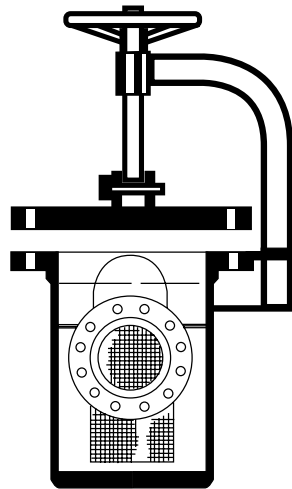

**Integral davit assembly cover**

The davit assembly cover can reduce any cover lift process to a one-man operation.

### Cover openings

The process of removing and replacing strainer access covers can result in costly maintenance or safety issues. In sizes larger than eight inches, the cover can easily exceed 150 lb (68 kg), which may require additional personnel or equipment. To eliminate the risks associated with this process, Eaton developed the integral davit assembly and hinged cover designs.

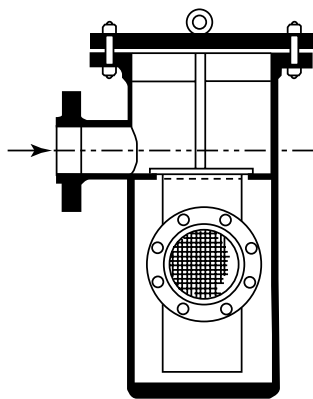

**Rotated nozzles**

Right angle design can eliminate the requirement for an elbow in the downstream piping.

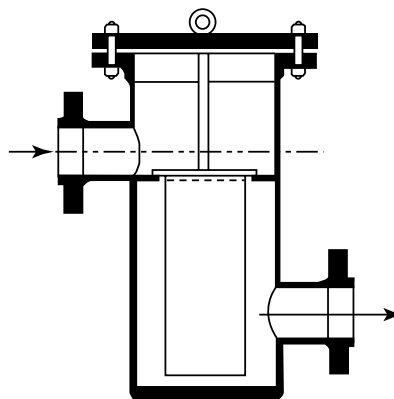

**Offset nozzles**

By lowering or raising either nozzle, serious alignment and support problems can be avoided.

### Nozzle placement

Fabricated strainers are available with many nozzle design options to adapt to existing or planned piping schemes.

### Steam jacket option

Custom fabricated simplex basket and T strainers in all sizes are available with an optional carbon steel or stainless steel steam jacket, rated for service up to 450 °F (232 °C). The steam jacket keeps the strainer at the high temperatures required to transport heavy, viscous fluids without affecting the function or normal maintenance of the strainer.



*Powering Business Worldwide*



# TECHNICAL INFORMATION

## Fabricated Pipeline Strainers

### Backflush/backwash option

Available in custom fabricated Model 90 simplex strainer and Model 950B duplex strainer.

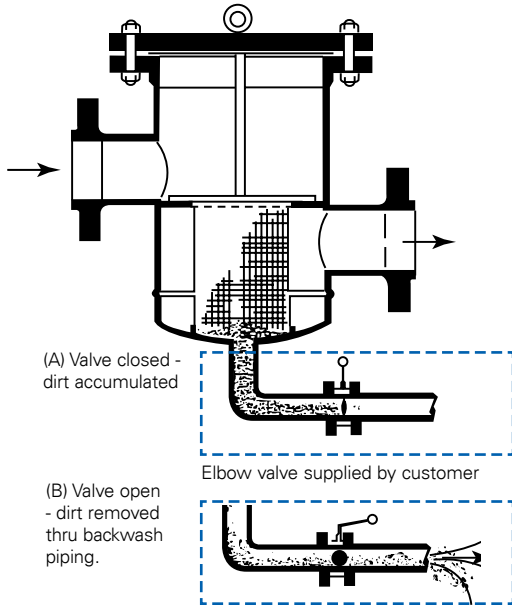

In many systems with heavy and well-defined solids, sediment accumulates. When the backflush valve is open, the differential between the operating pressure and the backflush system removes the sediment without shutting the system down. Figures A and B show the backflushing process.

Backwashing is a process similar to backflushing, but with a reverse flow into an empty strainer. Fluid flowing back through the element removes residual sediment left in the filter from backflushing.

### Basket effective area

Strainer model	Pipe size (in)	Perforation size	Nominal area of pipe (sq in)	Gross screen area (sq in)	Free area (sq in)	Ratio free area to pipe area
90	2	5/32	3.35	78	49	14.60
90	3	5/32	7.39	94	59	8.00
90	4	5/32	12.73	151	95	7.46
90	5	5/32	20.00	204	128	6.40
90	6	5/32	28.90	283	178	6.16
90	8	5/32	50.02	478	301	6.02
90	10	5/32	78.85	691	435	5.52
90	12	5/32	111.93	942	593	5.30
90	14	5/32	135.28	1320	832	6.15
90	16	5/32	176.71	1659	1045	5.91
90	18	5/32	223.68	1979	1247	5.57
90	20	5/32	277.95	2513	1583	5.70
90	24	5/32	402.00	4071	2565	6.38
950B	2	5/32	3.35	78	49	1460
950B	3	5/32	7.39	94	59	8.00
950B	4	5/32	12.73	151	95	7.46
950B	5	5/32	20.00	204	128	6.40
950B	6	5/32	28.90	283	178	6.16
950B	8	5/32	50.02	478	301	6.02
950B	10	5/32	78.85	691	435	5.52
950B	12	5/32	111.93	942	593	5.30
950B	14	5/32	135.28	1320	832	6.15
950B	16	5/32	176.71	1659	1045	5.91
950B	18	5/32	223.68	1979	1247	5.57
950B	20	5/32	277.95	2513	1583	5.70
950B	24	5/32	402.00	4071	2565	6.38
91	2	5/32	3.35	23	14.26	4.26
91	3	5/32	7.39	41	25.42	3.44
91	4	5/32	12.73	58	35.96	2.82
91	5	5/32	20.00	82	50.84	2.54
91	6	5/32	28.90	105	65.10	2.25
91	8	5/32	50.02	167	103.54	2.07
91	10	5/32	78.85	234	145.08	1.84
91	12	5/32	111.93	322	199.64	1.78
91	14	5/32	135.28	419	259.78	1.92
91	16	5/32	176.71	511	316.82	1.72
91	18	5/32	223.68	639	398.18	1.77
91	20	5/32	277.95	781	484.22	1.74
91	24	5/32	402.00	1057	655.34	1.63

**North America**  
44 Apple Street  
Tinton Falls, NJ 07724  
Toll Free: 800 656-3344  
(North America only)  
Tel: +1 732 212-4700

**Europe/Africa/Middle East**  
Auf der Heide 2  
53947 Nettersheim, Germany  
Tel: +49 2486 809-0

**Internormen** Product Line  
Friedensstraße 41  
68804 Altlufsheim, Germany  
Tel: +49 6205 2094-0

**Begerow** Product Line  
An den Nahewiesen 24  
55450 Langenlonsheim, Germany  
Tel: +49 6704 204-0

**China**  
No. 3, Lane 280,  
Linhong Road  
Changning District, 200335  
Shanghai, P.R. China  
Tel: +86 21 5200-0099

**Singapore**  
4 Loyang Lane #04-01/02  
Singapore 508914  
Tel: +65 6825-1668

**Brazil**  
Av. Julia Gaioli, 474 – Bonsucesso  
07251-500 – Guarulhos, Brazil  
Tel: +55 11 2465-8822

**For more information, please  
email us at [filtration@eaton.com](mailto:filtration@eaton.com)  
or visit [www.eaton.com/filtration](http://www.eaton.com/filtration)**

© 2014 Eaton. All rights reserved. All trademarks and registered trademarks are the property of their respective owners. All information and recommendations appearing in this brochure concerning the use of products described herein are based on tests believed to be reliable. However, it is the user's responsibility to determine the suitability for his own use of such products. Since the actual use by others is beyond our control, no guarantee, expressed or implied, is made by Eaton as to the effects of such use or the results to be obtained. Eaton assumes no liability arising out of the use by others of such products. Nor is the information herein to be construed as absolutely complete, since additional information may be necessary or desirable when particular or exceptional conditions or circumstances exist or because of applicable laws or government regulations.

US  
EF-SSEA-23  
6-2014

# TECHNICAL INFORMATION

## Fabricated Pipeline Strainers

**North America**  
44 Apple Street  
Tinton Falls, NJ 07724  
Toll Free: 800 656-3344  
(North America only)  
Tel: +1 732 212-4700

**Europe/Africa/Middle East**  
Auf der Heide 2  
53947 Nettersheim, Germany  
Tel: +49 2486 809-0

**Internormen Product Line**  
Friedensstraße 41  
68804 Altluisheim, Germany  
Tel: +49 6205 2094-0

**Begerow Product Line**  
An den Nahewiesen 24  
55450 Langenlonsheim, Germany  
Tel: +49 6704 204-0

**China**  
No. 3, Lane 280,  
Linhong Road  
Changning District, 200335  
Shanghai, P.R. China  
Tel: +86 21 5200-0099

**Singapore**  
4 Loyang Lane #04-01/02  
Singapore 508914  
Tel: +65 6825-1668

**Brazil**  
Av. Julia Gaioli, 474 – Bonsucesso  
07251-500 – Guarulhos, Brazil  
Tel: +55 11 2465-8822

**For more information, please  
email us at [filtration@eaton.com](mailto:filtration@eaton.com)  
or visit [www.eaton.com/filtration](http://www.eaton.com/filtration)**

© 2014 Eaton. All rights reserved. All trademarks and registered trademarks are the property of their respective owners. All information and recommendations appearing in this brochure concerning the use of products described herein are based on tests believed to be reliable. However, it is the user's responsibility to determine the suitability for his own use of such products. Since the actual use by others is beyond our control, no guarantee, expressed or implied, is made by Eaton as to the effects of such use or the results to be obtained. Eaton assumes no liability arising out of the use by others of such products. Nor is the information herein to be construed as absolutely complete, since additional information may be necessary or desirable when particular or exceptional conditions or circumstances exist or because of applicable laws or government regulations.

US  
EF-SSEA-23  
6-2014



Powering Business Worldwide

