

FILTER UNIT, mobile pneumatical Series UMP 40 PN 4

Sheet No.
4048 A

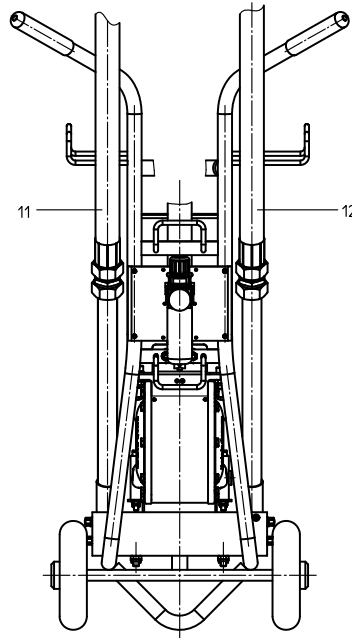
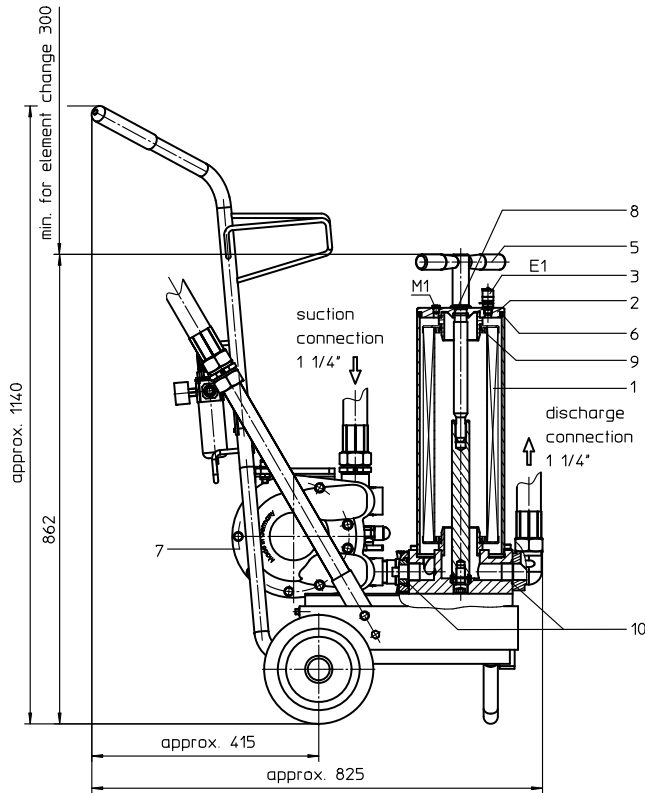

1. Type index:

1.1. Filter unit: (ordering example)

UMP. 40. 6VG. 10. B. P. -. P107. L49. L50. -

1	2	3	4	5	6	7	8	9	10	11
---	---	---	---	---	---	---	---	---	----	----

- 1 series:
UMP = filter unit, mobile pneumatical
- 2 nominal size: 40
- 3 filter-material and filter-fineness:
10 VG = 10 $\mu\text{m}_{(e)}$, 6 VG = 7 $\mu\text{m}_{(e)}$, 3 VG = 5 $\mu\text{m}_{(e)}$, 1 VG = 4 $\mu\text{m}_{(e)}$ Interpor fleece (glass fibre)
10 WVG = 10 $\mu\text{m}_{(e)}$, 3 WVG = 5 $\mu\text{m}_{(e)}$ Watersorp-filter element
- 4 resistance of pressure difference for filter element:
10 = Δp 10 bar
- 5 filter element design:
B = both sides open
- 6 sealing material:
P = Nitrile (NBR)
V = Viton (FPM), by agreement
- 7 filter element specification:
- = standard
VA = stainless steel
IS06 = see sheet-no. 31601
- 8 pump unit:
P107 = pump unit 107.UMP40 (standard-pump unit)
drive: (P = pneumatical)

pressure air	operating pressure	volume flow	viscosity
filtrated/oiled	0,5 – 8,0 bar	min. 40 l/min ¹⁾	1 - 1000 mm ² /s

¹⁾ characteristic curves under item 4 technical data

- 9 suction connection 1 1/4" :
L49 = hose-fitting-lance
- 10 discharge connection 1 1/4" :
L50 = hose-fitting-lance
- 11 clogging indicator at M1:
- = without
O = visual, 2,5 bar

1.2. Filter element: (ordering example)

01NR. 630. 6VG. 10. B. P. -

1	2	3	4	5	6	7
---	---	---	---	---	---	---

- 1 series:
01NR. = standard-return-line filter element according to DIN 24550, T4
- 2 nominal size: 630
- 3 - 7 | see type index-filter unit

Assignment of connections and functions:

- E1: venting of filter, mini-measuring connection MA.1.ST, see sheet-no.1650
- E2: drainage of filter, dirt side
- E3: drainage of filter, clean side
- M1: measure connection in the housing cover, dirt side

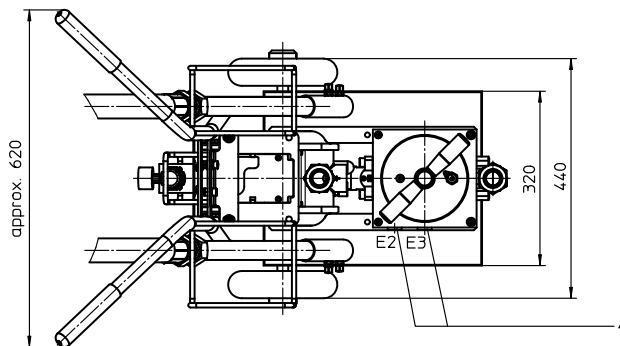

Changes of measures and design are subject to alteration!



Friedensstrasse 41, 68804 Altlusheim, Germany

phone +49 - (0)6205 - 2094-0 e-mail info-internormen@eaton.com
fax +49 - (0)6205 - 2094-40 url www.eaton.com/filtration

2. Spare parts:

item	qty.	designation	dimension	article-no.
1	1	filter element	01NR. 630...	
2	1	housing cover	30600-3	315492
3	1	mini-measuring connection	MA.1.ST	305453
4	2	screw plug	G ½	304678
5	1	straining screw	30595-3	316312
6	1	O-ring	140 x 6	315392 (NBR)
7	1	double membrane pump		341275
8	1	O-ring	22 x 3	304387 (NBR)
9	2	O-ring	70 x 4	306253 (NBR)
10	1	O-ring	37,69 x 3,53	304353 (NBR)
12	1	suction hose 1 ¼"		341970
13	1	discharge hose 1 ¼"		341971

3. Designation:

The mobile filter unit is intended for oil maintenance on hydraulic systems.

The area of application comprises:

- secondary flow filtration in addition to the existing operating filter
- secondary flow filtration without the action of the operating filter
- filtration when filling the oil reservoir.

The filter unit must not be used to pump contaminated hydraulic fluids and is therefore designed without a switchover fitting to bypass the filter. The compact structural design on a base plate without pipe satisfies the prerequisites for small dimensions and high reliability. The transporting trolley makes it possible to move close up to confined locations with difficult access, and to fix the accessories (such as hoses and the connection cable) in a safe and reliable manner.

Oil flowing out of the suction and/or discharge hose or the outflow openings is collected by the filter unit's oil trough, without causing any environmental damage. The suction hose DN 32 and the discharge hose DN 32 are approximately 2700 mm long inclusive of the lance.

The device is equipped with a double membrane pump. The flow conveyed by the pump is fed over a filter element to DIN 24550, T4, nominal size 630. Depending on the customer's wishes, the filter fineness is either 4, 5, 7 or 10 µm_(c).

The filter element can be changed without tools. After removing the straining screw and taking off the housing cover, the filter element is accessible and it can be exchanged. The filter elements are supplied complete with seals. Since it is not possible to clean the elements, the user must always keep an adequate supply of spare elements in stock.

The line, venting and draining connections are identified according to their function. Drainage is necessary when cleaning the filter unit in connection with the change of filter element, and when changing the fluid medium.

4. Technical data:

filter-fineness:	4, 5, 7 or 10 µm _(c)
oil temperature:	-5°C to +60°C
weight:	approx. 48 kg
operating medium:	hydraulic oil based on mineral oil from 10 mm ² /s, other media on request
conductivity:	≥ 200 S/m
fluid sealing/membrane:	Viton / PTFE

Classified under the Pressure Vessel Directive 97/23/EC for mineral oil (fluid group 2), Article 3, Para. 3.

Classified under ATEX Directive 94/9/EC according to specific application (see questionnaire sheet-no. 34279-4).

characteristic diagram UMP40; viscosity 30mm²/s

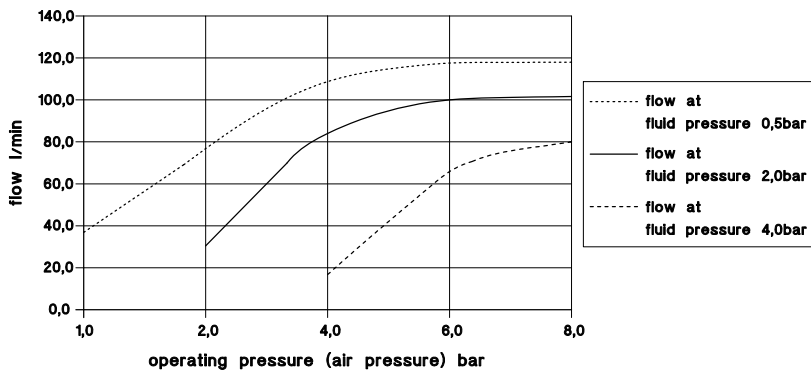

characteristic diagram UMP40; viscosity 100mm²/s

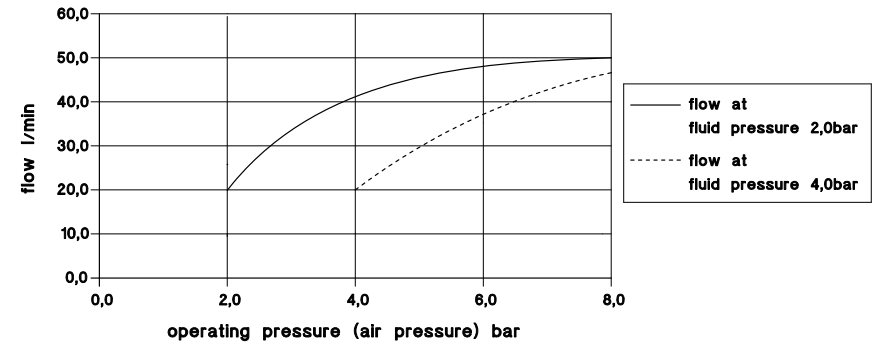

5. Symbols:

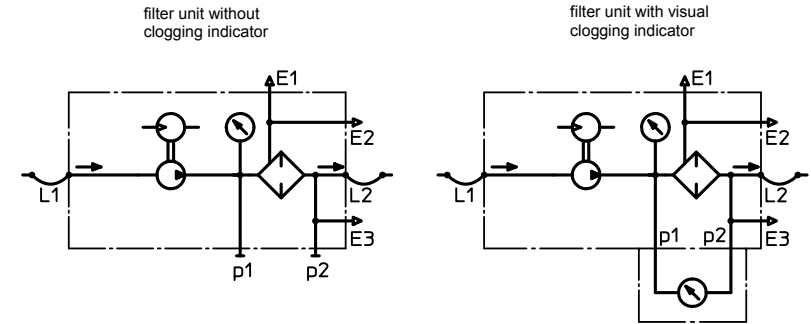

6. Test methods:

Filter elements are tested according to the following ISO standards:

ISO 2941	Verification of collapse/burst resistance
ISO 2942	Verification of fabrication integrity
ISO 2943	Verification of material compatibility with fluids
ISO 3723	Method for end load test
ISO 3724	Verification of flow fatigue characteristics
ISO 3968	Evaluation of pressure drop versus flow characteristics
ISO 16889	Multi-pass method for evaluating filtration performance