

# BR Series Vent Breathers

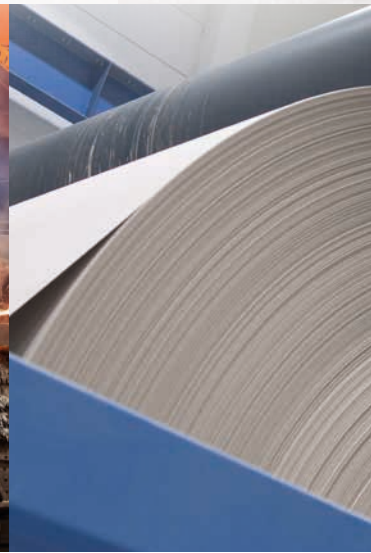

*Powering Business Worldwide*

# Protection for hydraulic reservoirs

Hydraulic reservoirs “breathe” air in and out as the oil level rises and falls. This circulating air contains particles and moisture that can cause corrosion, increase equipment wear and reduce fluid performance.

The Eaton BR series of vent breathers are designed to protect the hydraulic reservoirs from these airborne contaminants. The BR210 Dirt-Gate vent breather is developed to protect systems from particulates in the air. The BR110 H<sub>2</sub>O-Gate vent breather protects systems from both particulate and moisture in the air.

In typical systems, the internal hydraulic fluid is warmer than the external environment. This difference in temperatures causes moisture to form inside the reservoir. By using the BR110 vent breather it lowers the dew point temperature below the ambient temperature and condensation does not form.

## Markets

- Hydraulic power units
- Metal forming
- Marine
- Material handling
- Gearboxes

# BR210

## Dirt-Gate™ vent breather



### Protection in dry environments

The BR210 vent breather is designed to filter out airborne solid particles before it enters the hydraulic reservoir and contaminates the hydraulic system.

As the oil level drops in the oil reservoir, airborne solid particles get drawn in. These solid particles are typically very abrasive and can have a “sand blasting” effect to the hydraulic systems internal components. Depending on the selected filtering level of the hydraulic oil filters, they may not be able to effectively capture and remove all the particles after they have been drawn in. The most effective and cost efficient way to protect the system from the airborne solid particles is to block them from entering in the first place by installing the BR210 vent breather.

### Features:

- Filters out particles
- Durable plastic housing: Protects the filtration media from external splashing
- High efficiency: (99% at 2 µm)
- Very low pressure drop
- Temperature resistant up to 121°C
- Rated up to 708 l/min
- Visual mechanical indicator: The indicator actuates when particles have blocked the media, before the pump cavitates
- Easy installation: Lightweight design can be hand tightened onto adapter.

### Dirt-Gate specifications (mm)

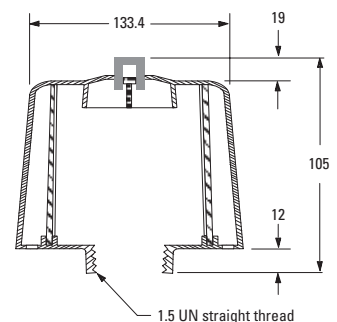

# BR110

**H<sub>2</sub>O-Gate™  
vent breather**



## Blocking moisture and preventing condensation

In addition to blocking solid particles the BR110 vent breather prevents moisture from entering reservoirs.

Apart from solid particles, water is one of the most prevalent destructive contaminants in oil. Using the BR110 vent breather not only blocks moisture from entering through the breather but can lower the moisture level within the reservoir. This style of breather is best suited on systems with cylinders that cause regular changes in the oil reservoir levels and operate in high humidity or high temperature change environments.

## In addition to the BR210 benefits, the BR110 also features:

- Proprietary media:**  
Reduces dew point temperature to prevent condensation and is 99.7% efficient in blocking particles 3 μm and larger.
- Continuous air exchange:**  
The media used prevents moisture from entering the tank as well as allowing moisture to escape the tank.

## H<sub>2</sub>O-Gate specifications (mm)

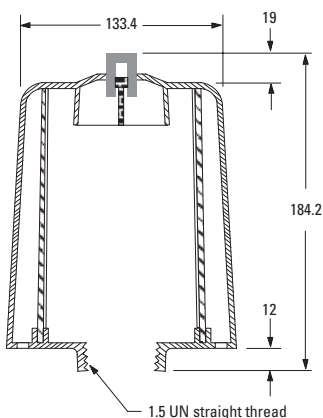

## Reduce reservoir moisture

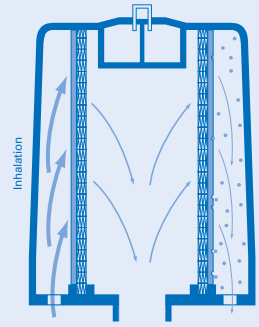

### Performs as a gate

During the “inhalation” cycle, the H<sub>2</sub>O-Gate proprietary media blocks moisture from entering the reservoir. During the “exhalation” cycle, the media allows the moisture in the reservoir air to exit. The moisture is carried off the media by the exiting air, restoring the media’s water barrier capacity, and the moisture barrier mechanism is not affected by the amount of exposure to moisture. The reservoir air is maintained at a low relative humidity, and more importantly, at a lower dew point temperature than the ambient temperature.

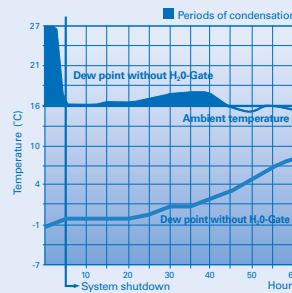

### Works even when the system is shut down.

The H<sub>2</sub>O-Gate vent breather retards the vapor equilibrium process and works to prevent condensation even after the system is shut and cooled down, such as overnight. As this chart illustrates, the dewpoint is slow to climb, even after the system temperature has dropped to the ambient temperature. Once the system has reached ambient temperature, condensation does not occur.

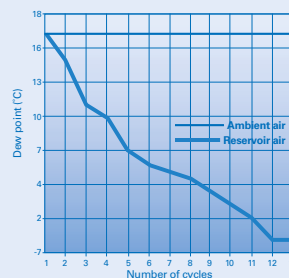

### Reduces humidity inside reservoir.

The H<sub>2</sub>O-Gate vent breather lowers and stabilizes the relative humidity of air inside the reservoir, leading to a lower dew point (dewpoint < ambient temperature = NO CONDENSATION) at a rate and amount that will be dependent upon several conditions: the ambient conditions, the internal reservoir heat, amount and frequency of reservoir air flow through the vent, and the temperature of the reservoir surfaces.

**North America**

18684 Lake Drive East  
Chanhassen, MN 55317  
Toll Free: +1 800-656-3344  
(North America only)  
Tel: +1 732-212-4700

**Europe/Africa/Middle East**

Auf der Heide 2  
53947 Nettersheim, Germany  
Tel: +49 2486 809-0

Friedensstraße 41  
68804 Altlußheim, Germany  
Tel: +49 6205 2094-0

An den Nahewiesen 24  
55450 Langenlonsheim, Germany  
Tel: +49 6704 204-0

**Greater China**

No. 7, Lane 280,  
Linhong Road  
Changning District, 200335  
Shanghai, P.R. China  
Tel: +86 21 2899-3687

**Asia-Pacific**

100G Pasir Panjang Road  
#07-08 Interlocal Centre  
Singapore 118523  
Tel: +65 6825-1620

**For more information, please  
email us at [filtration@eaton.com](mailto:filtration@eaton.com)  
or visit [www.eaton.com/filtration](http://www.eaton.com/filtration)**

© 2023 Eaton. All rights reserved. All trademarks and registered trademarks are the property of their respective owners. All information and recommendations appearing in this brochure concerning the use of products described herein are based on tests believed to be reliable. However, it is the user's responsibility to determine the suitability for his own use of such products. Since the actual use by others is beyond our control, no guarantee, expressed or implied, is made by Eaton as to the effects of such use or the results to be obtained. Eaton assumes no liability arising out of the use by others of such products. Nor is the information herein to be construed as absolutely complete, since additional information may be necessary or desirable when particular or exceptional conditions or circumstances exist or because of applicable laws or government regulations.

EN  
12-2023

