

Series BR 110

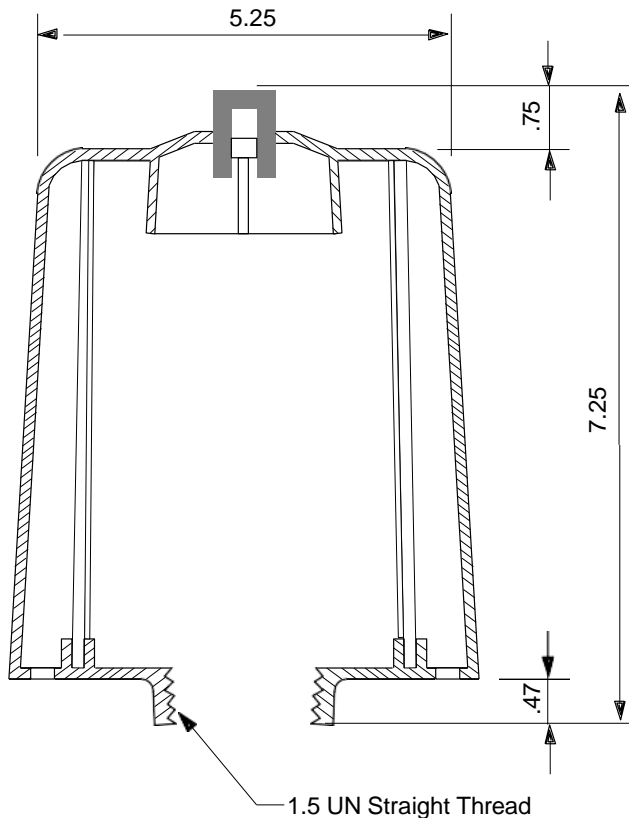

Features & Benefits

- Rugged ABS plastic housing can be exposed to temperatures as high as 250° F, and is corrosion resistant.
- Visual mechanical indicator, which triggers at Δp 1 psid (during exhalation).
- Easy installation. Lightweight design requires only hand tightening.
- Low pressure drop across filter media reduces stress on reservoir and system components.
- Reversible flow-through media in the H₂O-Gate allows moisture to exit while filter regenerates its capacity to prevent moisture ingress.
- Plated steel core prevents filter media distortion.

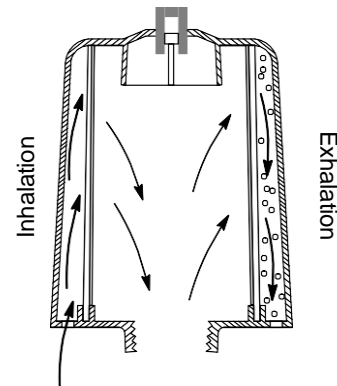

Performs as a gate.

During the "inhalation" cycle, the H₂O-Gate proprietary media blocks the water vapor from entering the reservoir. During the "exhalation" cycle, the media allows the moisture in the reservoir air to exit. The moisture is blown off the media by the exiting air, restoring the media's water barrier capacity, and the moisture barrier mechanism is not affected by the amount of exposure to moisture. The reservoir air is maintained at a low relative humidity, and more importantly, at a lower dew point temperature than the ambient temperature.

Technical data

Housing material:	ABS Plastic
Temperatures:	up to 250°F
Efficiency:	99% at 3 micron
Weight:	.97 lbs.

Dimensions: inches

Designs and performance values are subject to change.

Pressure drop

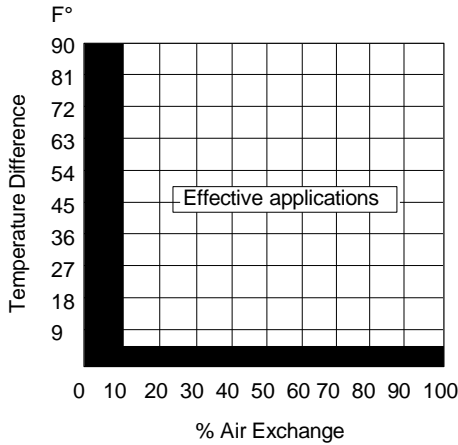

Highly effective

In an operating system, the H₂O-Gate vent breather creates a moisture barrier when there is a 5° F degree difference between reservoir and ambient temperature and when there is a 10% exchange of air volume above the fluid.

NOTE:

Mobile systems may actuate the indicator due to vibrations, in which case the element should be changed after 500 hours of operation.

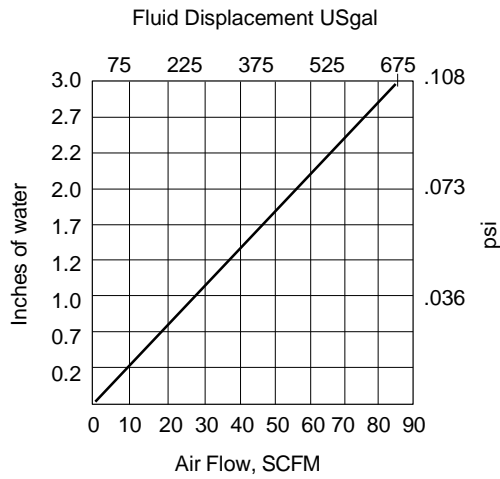

Low pressure drop across media.

The Δp indicator triggers at Δp 1psid (during exhalation).

Adapters (Installation/Dimensions)

Threaded Pipe Adaptor

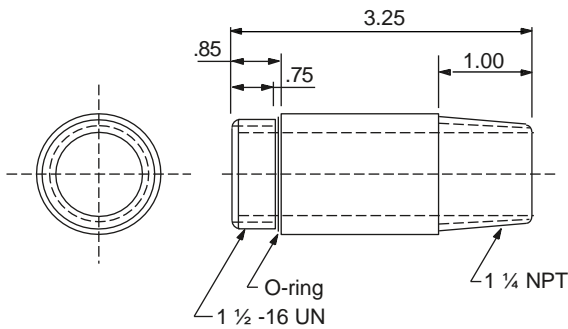

MODELS AND PART NUMBERS

PART NUMBERS Applicable	Description	Vent Filter
924710	Bayonet, no check	BR110
P-077002	Threaded pipe	BR110

Bayonet adaptor

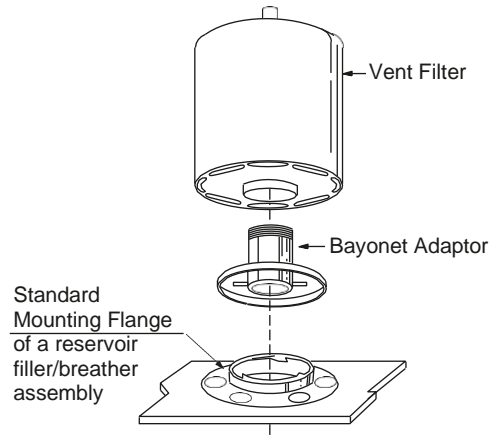

All Eaton Vent filters are easily applied to reservoirs via Spin-On adaptors.

North America
18684 Lake Drive East
Chanhausen, MN 55317
Toll Free: +1 800-656-3344
(North America only)
Tel: +1 732-212-4700

Europe/Africa/Middle East
Auf der Heide 2
53947 Nettersheim, Germany
Tel: +49 2486 809-0

Friedensstraße 41
68804 Altlußheim, Germany
Tel: +49 6205 2094-0

An den Nahewiesen 24
55450 Langenlonsheim, Germany
Tel: +49 6704 204-0

Greater China
No. 7, Lane 280,
Linhong Road
Changning District, 200335
Shanghai, P.R. China
Tel: +86 21 5200-0099

Asia-Pacific
100G Pasir Panjang Road
#07-08 Interlocal Centre
Singapore 118523
Tel: +65 6825-1668

For more information, please
email us at filtration@eaton.com
or visit www.eaton.com/filtration

© 2023 Eaton. All rights reserved. All trademarks and registered trademarks are the property of their respective owners. All information and recommendations appearing in this brochure concerning the use of products described herein are based on tests believed to be reliable. However, it is the user's responsibility to determine the suitability for his own use of such products. Since the actual use by others is beyond our control, no guarantee, expressed or implied, is made by Eaton as to the effects of such use or the results to be obtained. Eaton assumes no liability arising out of the use by others of such products. Nor is the information herein to be construed as absolutely complete, since additional information may be necessary or desirable when particular or exceptional conditions or circumstances exist or because of applicable laws or government regulations.