

# Series TWF 4000 DN50-65 PN 25

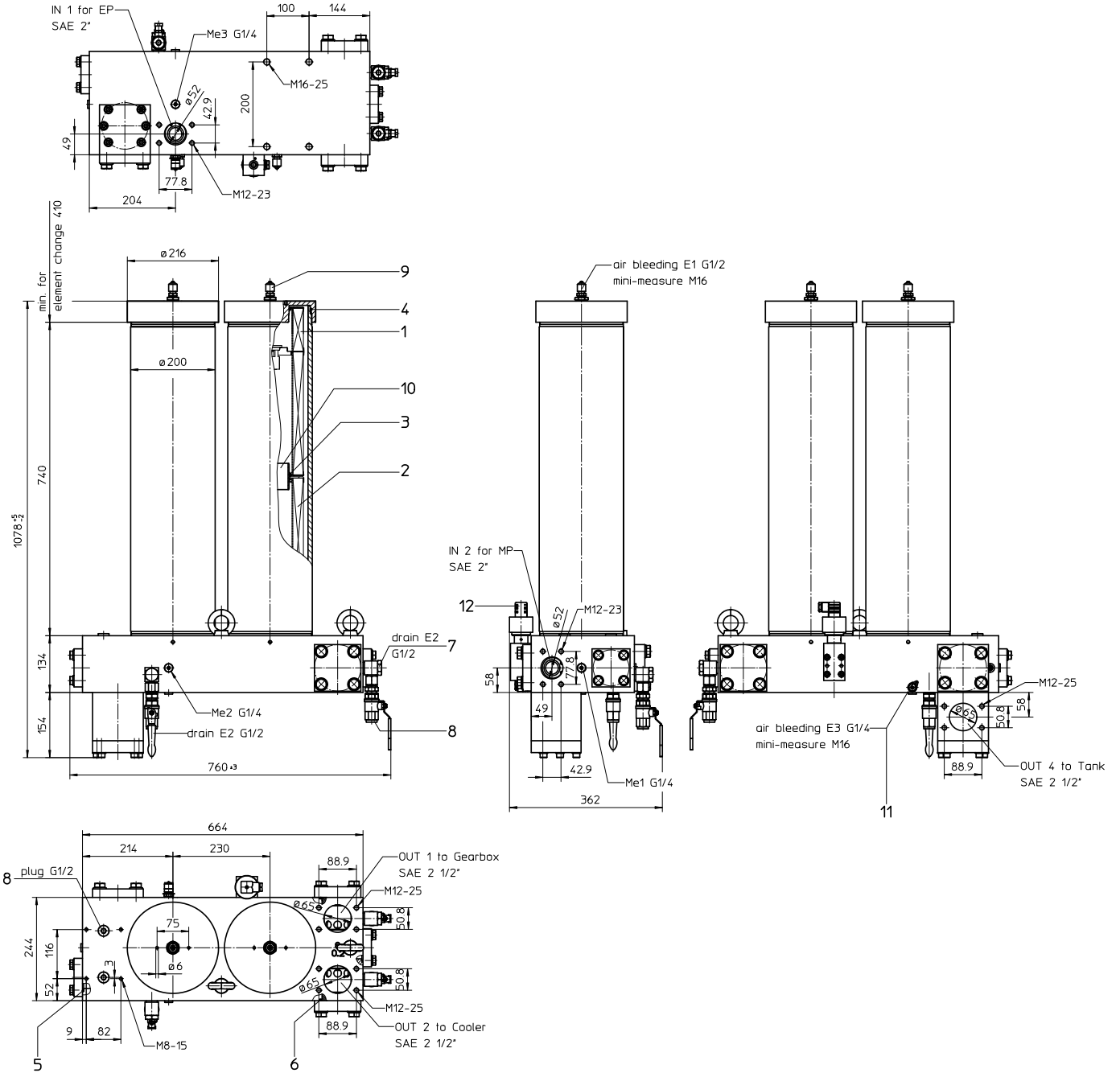

Weight: approx. 120 kg

Dimensions: mm

Designs and performance values are subject to change.

# TWIN Filter

## Series TWF 4000

### DN 50-65 PN 25

#### Description:

The TWIN-filter combination of the type TWF 4000 are suitable for a working pressure up to 25 bar.

The connection dimensions and outside dimensions of these elements are according to DIN 24550, T4.

The two level filter element is divided in a main and an auxiliary level with different filter fineness and different filter surface area. The pressure difference valve VD1 is located between the main level HS (fine filter) and the auxiliary level NS (coarse filter).

The total fluid flow Q will be directed through the main level of the two-level element as long as the pressure difference on this filter element is greater than the opening pressure of the pressure difference valve VD1. If the pressure difference valve VD1 is opened the partial flow Q1 will be filtered over the auxiliary level.

The breather connection E1 on the filter's lid can allow the offset of another partial flow Q3. This partial flow Q3 will only be filtered by the auxiliary level NS of the filter element and is even available if the VD1 is closed.

The filter elements consist of star like folded filtration material, which is placed around the supportive tubes from the outside and which is adhered to the end caps. The direction of flow is from the outside to the inside. Filter elements can only be operated in the displayed arrangement. In order to prevent reverse installation, the filter housing has a mechanical lock, which does not allow the filter lid to be screwed on the filter if installed in a wrong way.

Eaton filter elements are known as elements with a high intrinsic stability and an excellent filtration capability, a high dirt-retaining capacity and a long service life.

Eaton filter are suitable for all petroleum based fluids, HW-emulsions, most synthetic hydraulic fluids and lubrication oils.

Ship classifications available upon request.

#### 1. Type index:

##### 1.1. Complete filter: (ordering example)

**TWF. 4000. V. 1. 2. FS. 8. 9. S14. -. VS5**

1	2	3	4	5	6	7	8	9	10	11
1	<b>series:</b> TWF = TWIN-filter combination									
2	<b>nominal size:</b> 4000									
3	<b>sealing material:</b> V = Viton (FPM) P = Nitrile (NBR) HNBR = Hydrated Nitril-Butadien-Rubber (HNBR); WS 20.357									
4	<b>filter element:</b> 1 = stage filter element, see position 1.2									
5	<b>filter element:</b> 2 = single filter element, see position 1.3									
6	<b>process connection:</b> FS = SAE-flange 3000 PSI									
7	<b>process connection size „IN1 / IN2“:</b> 8 = 2"									
8	<b>process connection size „OUT1 / OUT2 / OUT4“:</b> 9 = 2 1/2"									
9	<b>internal valve:</b> S14 = with by-pass valve Δp 14 bar									
10	<b>filter housing specification:</b> - = standard									
11	<b>clogging sensor:</b> VS5 = electronic, see sheet-no. 1641									

##### 1.2. Stage filter element: (ordering example)

**01NR. 1000. 32227. 10VG. 25G. 25. B. V. -. S1**

1	2	3	4	5	6	7	8	9	10
1	<b>series:</b> 01NR. = standard return line filter element acc. to DIN 24 550, T4								
2	<b>nominal size:</b> 1000								
3	<b>execution</b> according to sheet-no. 32227								
4	<b>filter-material primary stage PS:</b> 10 VG, 6 VG, 3 VG microglass								
5	<b>filter-material secondary stage SS:</b> 80 G, 40 G, 25 G stainless steel wire mesh								
6	<b>filter element collapse rating:</b> 25 = Δp 25 bar								
7	<b>filter element design:</b> B = both sides open								
8	<b>sealing material:</b> V = Viton (FPM) P = Nitrile (NBR) HNBR = Hydrated Nitril-Butadien-Rubber (HNBR); WS 20.357								
9	<b>filter element specification:</b> - = standard								
10	<b>internal valve:</b> S1 = with pressure difference valve Δp 3,5 bar								

##### 1.3. Single filter element: (ordering example)

**01NR. 1000. 3VG. 10. B. V. -**

1	2	3	4	5	6	7
1	<b>series:</b> 01NR. = standard return line filter element acc. to DIN 24 550, T4					
2	<b>nominal size:</b> 1000					
3	<b>filter-material:</b> 10 VG, 6 VG, 3 VG microglass					
4	<b>filter element collapse rating:</b> 10 = Δp 10 bar					
5	<b>filter element design:</b> B = both sides open					
6	<b>sealing material:</b> V = Viton (FPM) P = Nitrile (NBR) HNBR = Hydrated Nitril-Butadien-Rubber (HNBR); WS 20.357					
7	<b>filter element specification:</b> - = standard					

## Technical data:

design temperature:	-20°C to +100°C
operating temperature:	-10°C to +80°C
operating medium	mineral oil, other media on request
max. operating pressure:	25 bar
test pressure:	36 bar
process connection:	SAE-flange 3000 PSI
housing material:	EN 573-EN-AW6082-T6
sealing material:	Viton (FPM), Nitrile (NBR) or hydrated Nitril-Butadien-Rubber (HNBR); WS 20.357
installation position:	vertical
measuring connections:	G ¼
drain- and bleeder connections:	G ½
volume tank:	2x 20 l

Classified under the Pressure Equipment Directive 2014/68/EU for mineral oil (fluid group 2), Article 4, Para. 3.  
 Classified under ATEX Directive 2014/34/EU according to specific application (see questionnaire sheet-no. 34279-4).

## Symbol:

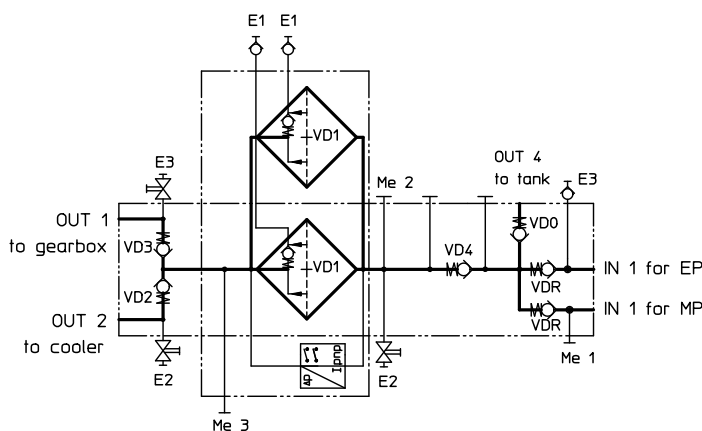

opening pressure of pressure difference valve:

- VD0  $\Delta p_0$  14 bar
- VD1  $\Delta p_0$  3,5 bar
- VD2  $\Delta p_0$  0,2 bar
- VD3  $\Delta p_0$  6,0 bar
- VD4  $\Delta p_0$  1,0 bar
- VDR  $\Delta p_0$  0,28 bar

## Spare parts:

item	qty.	designation	dimension	article-no.		
1	2	stage filter element	01NR.1000.32227....			
2	2	single filter element	01NR.1000....			
3	8	O-ring	90 x 4	307031 (FPM)	306941 (NBR)	318410 (HNBR)
4	4	O-ring	190 x 3,5	310278 (FPM)	- (NBR)	- (HNBR)
5	2	O-ring	60 x 3,5	304398 (FPM)	304377 (NBR)	321148 (HNBR)
6	3	O-ring	78 x 4	334646 (FPM)	327380 (NBR)	321148 (HNBR)
7	3	drain cock	EE.3.W.ST	310534		
8	5	screw plug	G ½	304678		
9	2	mini-measure connection	MA.3.ST	308630		
10	2	clip coupling	21689-4	313233		
11	1	mini-measuring connection	MA.1.ST	337393		
12	1	clogging sensor, electronic	VS5	see sheet-no. 1641		

## Test methods:

Filter elements are tested according to the following ISO standards:

ISO 2941	Verification of collapse/burst resistance
ISO 2942	Verification of fabrication integrity
ISO 2943	Verification of material compatibility with fluids
ISO 3723	Method for end load test
ISO 3724	Verification of flow fatigue characteristics
ISO 3968	Evaluation of pressure drop versus flow characteristics
ISO 16889	Multi-pass method for evaluating filtration performance

**North America**

44 Apple Street  
Tinton Falls, NJ 07724  
Toll Free: 800 656-3344  
(North America only)  
Tel: +1 732 212-4700

**Europe/Africa/Middle East**

Auf der Heide 2  
53947 Nettersheim, Germany  
Tel: +49 2486 809-0

Friedensstraße 41  
68804 Altlußheim, Germany  
Tel: +49 6205 2094-0

An den Nahewiesen 24  
55450 Langenlonsheim, Germany  
Tel: +49 6704 204-0

**China**

No. 3, Lane 280,  
Linhong Road  
Changning District, 200335  
Shanghai, P.R. China  
Tel: +86 21 5200-0099

**Singapore**

4 Loyang Lane #04-01/02  
Singapore 508914  
Tel: +65 6825-1668

**Brazil**

Rua Clark, 2061 - Macuco  
13279-400 - Valinhos, Brazil  
Tel: +55 11 3616-8400

**For more information, please  
email us at [filtration@eaton.com](mailto:filtration@eaton.com)  
or visit [www.eaton.com/filtration](http://www.eaton.com/filtration)**

© 2015 Eaton. All rights reserved. All trademarks and registered trademarks are the property of their respective owners. All information and recommendations appearing in this brochure concerning the use of products described herein are based on tests believed to be reliable. However, it is the user's responsibility to determine the suitability for his own use of such products. Since the actual use by others is beyond our control, no guarantee, expressed or implied, is made by Eaton as to the effects of such use or the results to be obtained. Eaton assumes no liability arising out of the use by others of such products. Nor is the information herein to be construed as absolutely complete, since additional information may be necessary or desirable when particular or exceptional conditions or circumstances exist or because of applicable laws or government regulations.