

Series TNRS 101

DN25 PN10

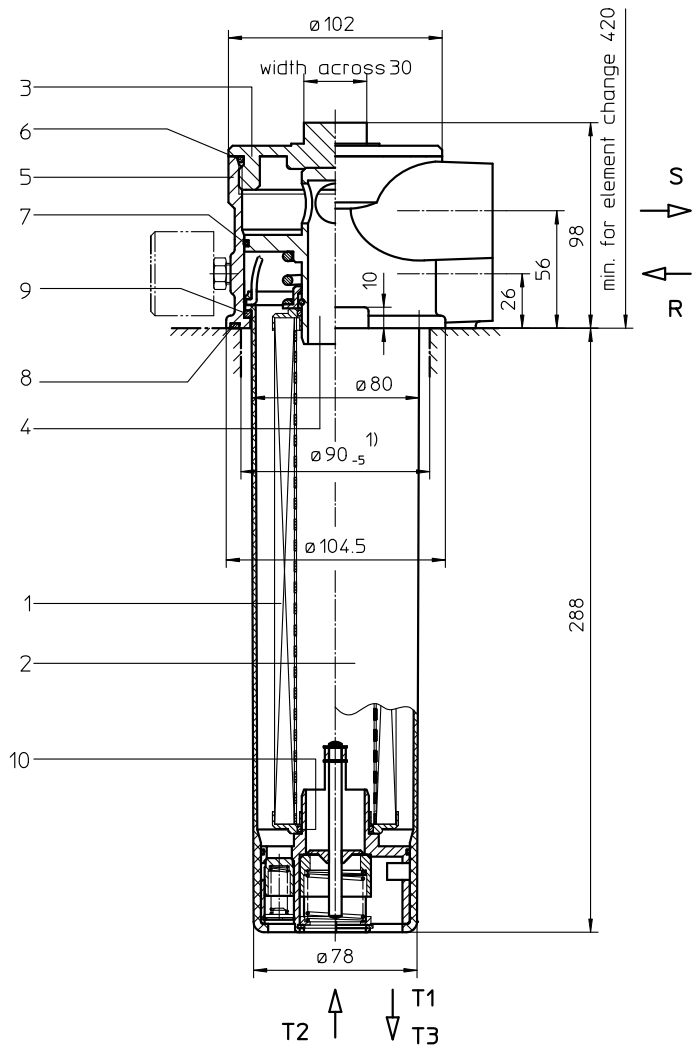

1) tank cutout according to DIN 24550, T5

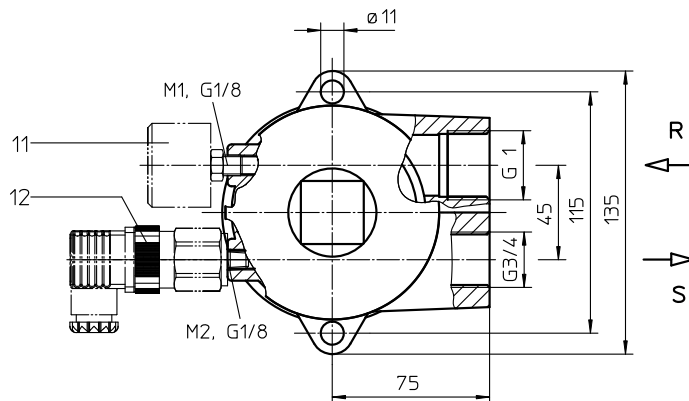

Weight: approx. 2,5 kg

Dimensions: mm

Designs and performance values are subject to change.

Return Line Filter

Series TNRS 101

DN25 PN10

Description:

Return-line filters in the TNRS 101 series are suitable for a working pressure up to 10 bar. Pressure peaks will be absorbed by a sufficient margin of safety.

TNRS series are tank-top mounted in-line filters. In addition to the return-line connection, they have a suction connection on the clean-side. This suction connection has a preload pressure (fitting pressure) of $\geq 0,5$ bar.

This combination, return-line and suction filter, is for hydraulic circuits which are equipped with a minimum 2 feed pumps (2 hydraulic circuits). The preload suction connection is for the full volume flow filtration of the pump with the smaller volume flow.

The operating status in general wherein the preload pressure is effecting the Q_R (return-line flow) $>$ Q_S (suction flow). When the operating status is $Q_R = Q_S$ no preload pressure is effective.

During the operating status $Q_R < Q_S$ the suction valve is effective operates at the connection T2, what makes a feeding out of the receptable possible without preload pressure and without filter efficiency.

The filter element according to DIN 24550, T4 consists of star-shaped, pleated filter material, which is supported on the inside by a perforated core tube and is bonded to the end caps with a high-quality adhesive. The flow direction is from outside to inside.

For cleaning the stainless steel mesh element (see special leaflets 21070-4 and 39448-4) or changing the filter element, remove the cover and take out the element. The mesh elements are not guaranteed to maintain 100% performance after cleaning.

Filters finer than 40 μ m use the disposable elements made of paper or microglass. Filter elements as fine as 5 μ m(c) are available; finer filter elements on request.

Eaton filter elements are known as stable elements which have excellent filtration capabilities and a high dirt retaining capacity, therefore having a long service life. Due to its practical design, the return-line filter is easy to service.

Eaton filter can be used for petroleum-based fluids, HW emulsions, water glycols, most synthetic fluids and lubrication fluids. Consult factory for specific fluid applications.

When changing the filter element, a detachable connection between the filter head and the filter bowl prevents dirty oil from flowing into the tank.

1. Type index:

1.1. Complete filter: (ordering example)

TNRS. 101. 10VG. 10. B. P. -. G. 5. -.

1	2	3	4	5	6	7	8	9	10
---	---	---	---	---	---	---	---	---	----

S2,5. Z. O. E2

11	12	13	14
----	----	----	----

- 1 | **series:**
TNRS = tank-mounted return-line filter with suction connection
- 2 | **nominal size:** 101
- 3 | **filter-material:**
80G, 40G, 25G stainless steel wire mesh
25VG, 16VG, 10VG, 6VG, 3VG microglass
10P paper
- 4 | **filter element collapse rating:**
10 = Δp 10 bar
- 5 | **filter element design:**
B = both sides open
- 6 | **sealing material:**
P = Nitrile (NBR)
V = Viton (FPM)
- 7 | **filter element specification:**
- = standard
- 8 | **process connection:**
G = thread connection according to DIN 3852, T2
- 9 | **process connection size:**
5 = G 1
- 10 | **filter housing specification:**
- = standard
- 11 | **internal valve:**
S2,5 = with by-pass valve Δp 2,5 bar
- 12 | **suction valve:**
Z = with suction valve
- 13 | **clogging indicator at M1:**
- = without
O = visual, see sheet-no. 1616
E1 = pressure switch, see sheet-no. 1616
E2 = pressure switch, see sheet-no. 1616
E5 = pressure switch, see sheet-no. 1616
- 14 | **preload pressure indicator at M2:**
- = without
E2 = pressure switch, see sheet-no. 1616

To add an indicator to your filter, use the corresponding indicator data sheet to find the indicator details and add them to the filter assembly model code.

1.2. Filter element: (ordering example)

01NR. 100. 10VG. 10. B. P. -

1	2	3	4	5	6	7
---	---	---	---	---	---	---

- 1 | **series:**
01NR. = standard-return-line filter element according to DIN 24550, T4
- 2 | **nominal size:** 100
- 3 | - 7 | see type index-complete filter

Technical data:

operating temperature:	-10°C to +100°C
operating medium	mineral oil, other media on request
max. operating pressure:	10 bar
opening pressure by-pass valve:	2,5 bar
opening pressure preload valve:	0,5 bar
opening pressure suction valve:	0,05 bar
line adapter:	thread G 1 and G ¾ according to DIN 3852, T2
housing material:	Al-casting, glass fibre reinforced polyamide (filter bowl)
sealing material:	Nitrile (NBR) or Viton (FPM), other materials on request
installation position:	vertical
volume tank:	1,3 l

Classified under the Pressure Equipment Directive 2014/68/EU for mineral oil (fluid group 2), Article 4, Para. 3.
 Classified under ATEX Directive 2014/34/EU according to specific application (see questionnaire sheet-no. 34279-4).

Pressure drop flow curves:

Filter calculation/sizing

The pressure drop of the assembly at a given flow rate Q is the sum of the housing Δp and the element Δp and is calculated as follows:

$$\Delta p_{assembly} = \Delta p_{housing} + \Delta p_{element}$$

$$\Delta p_{housing} = (\text{see } \Delta p = f(Q) - \text{characteristics})$$

$$\Delta p_{element} (mbar) = Q \left(\frac{l}{min} \right) \times \frac{MSK (mbar)}{10 (l/min)} \times v \left(\frac{mm^2}{s} \right) \times \frac{\rho (kg)}{0,876 (dm^3)}$$

For ease of calculation our Filter Selection tool is available online at www.eatonpowersource.com/calculators/filtration/

Material gradient coefficients (MSK) for filter elements

The material gradient coefficients in mbar/(l/min) apply to mineral oil (HLP) with a density of 0,876 kg/dm³ and a kinematic viscosity of 30 mm²/s (139 SUS). The pressure drop changes proportionally to the change in kinematic viscosity and density.

TNRS	VG					G			P
	3VG	6VG	10VG	16VG	25VG	25G	40G	80G	10P
101	1,677	1,164	0,745	0,649	0,443	0,0497	0,0464	0,0318	0,389

$\Delta p = f(Q)$ – characteristics according to ISO 3968

The pressure drop characteristics apply to mineral oil (HLP) with a density of 0,876 kg/dm³. The pressure drop changes proportionally to the density.

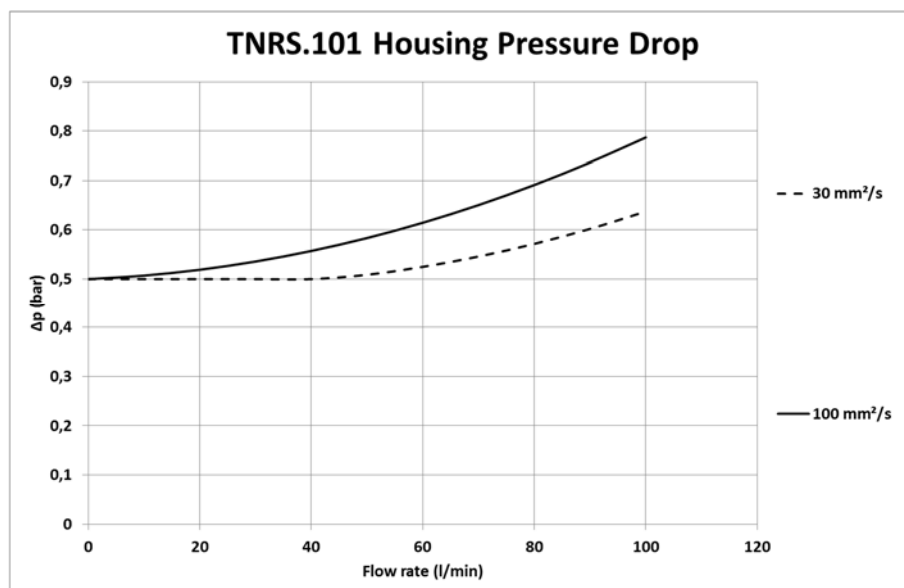

Symbols:

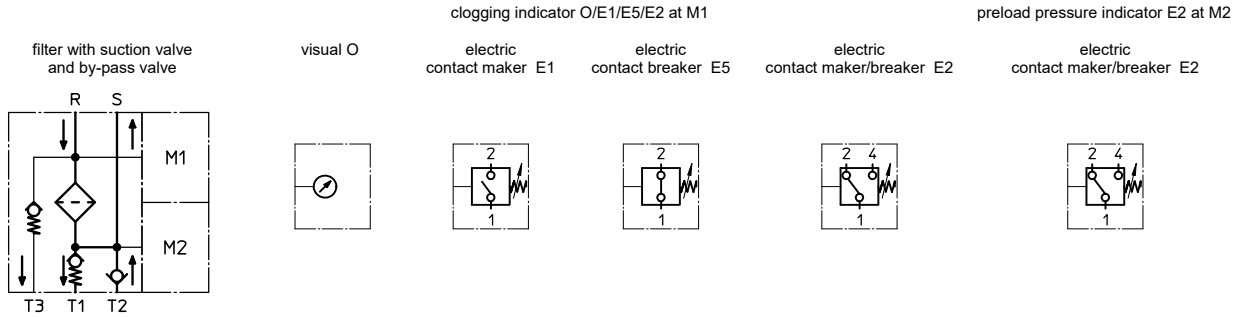

Spare parts:

item	qty.	designation	dimension	article-no.	
1	1	filter element	01NR.100...		
2	1	filter bowl with valve combination			
3	1	screw plug	M 92 x 3		313194
4	1	centering pivot			
5	1	filter head			
6	1	O-ring	82 x 4	331377 (NBR)	337365 (FPM)
7	1	O-ring	80 x 2,5	313179 (NBR)	314148 (FPM)
8	1	O-ring	92 x 3	325584 (NBR)	325585 (FPM)
9	1	O-ring	75 x 3	302215 (NBR)	304729 (FPM)
10	2	O-ring	32 x 3,5	304378 (NBR)	304401 (FPM)
11	1	clogging indicator at M1	O, E1, E5 or E2	see sheet-no. 1616	
12	1	preload pressure indicator at M2	E2	see sheet-no. 1616	

Test methods:

Filter elements are tested according to the following ISO standards:

ISO 2941	Verification of collapse/burst resistance
ISO 2942	Verification of fabrication integrity
ISO 2943	Verification of material compatibility with fluids
ISO 3723	Method for end load test
ISO 3724	Verification of flow fatigue characteristics
ISO 3968	Evaluation of pressure drop versus flow characteristics
ISO 16889	Multi-pass method for evaluating filtration performance

North America

44 Apple Street
Tinton Falls, NJ 07724
Toll Free: 800 656-3344
(North America only)
Tel: +1 732 212-4700

Europe/Africa/Middle East

Auf der Heide 2
53947 Nettersheim, Germany
Tel: +49 2486 809-0

Friedensstraße 41
68804 Altlußheim, Germany
Tel: +49 6205 2094-0

An den Nahewiesen 24
55450 Langenlonsheim, Germany
Tel: +49 6704 204-0

China

No. 3, Lane 280,
Linhong Road
Changning District, 200335
Shanghai, P.R. China
Tel: +86 21 5200-0099

Singapore

100G Pasir Panjang Road #07-08
Singapore 118523
Tel: +65 6825-1668

Brazil

Rua Clark, 2061 - Macuco
13279-400 - Valinhos, Brazil
Tel: +55 11 3616-8400

For more information, please
email us at filtration@eaton.com
or visit www.eaton.com/filtration

© 2019 Eaton. All rights reserved. All trademarks and registered trademarks are the property of their respective owners. All information and recommendations appearing in this brochure concerning the use of products described herein are based on tests believed to be reliable. However, it is the user's responsibility to determine the suitability for his own use of such products. Since the actual use by others is beyond our control, no guarantee, expressed or implied, is made by Eaton as to the effects of such use or the results to be obtained. Eaton assumes no liability arising out of the use by others of such products. Nor is the information herein to be construed as absolutely complete, since additional information may be necessary or desirable when particular or exceptional conditions or circumstances exist or because of applicable laws or government regulations.