

Series TEF 952 145 PSI

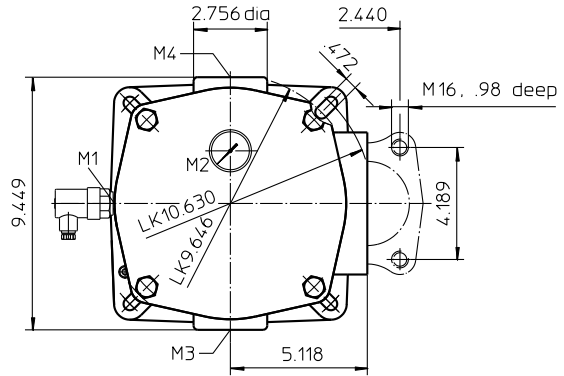

- 1) min. for element change without discharge pipe 22.04
- min. for element change with discharge pipe 30.70

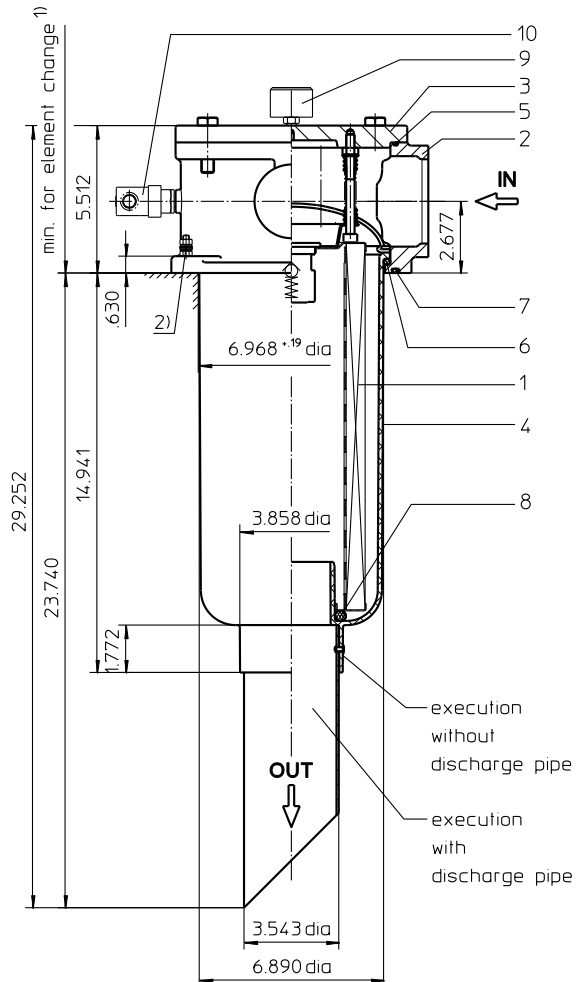

- 2) Connection for the potential equalization, only for application in the explosive area.

Weight: approx. 24 lbs.

Dimensions: inches

Designs and performance values are subject to change.



Powering Business Worldwide

Return Line Filter

Series TEF 952

145 PSI

Description:

Return-line filter series TEF 952 have a working pressure up to 145 PSI. Pressure peaks will be absorbed by a sufficient margin of safety.

The TEF-filters are directly mounted to the reservoir and connected to the return-line.

The filter element consists of a star-shaped, pleated filter material which is supported on the inside by a perforated core tube and is bonded to the end caps with a high-quality adhesive. The flow is from outside to inside.

For cleaning the stainless steel mesh element or changing the filter element, remove the cover and take out the element. The mesh elements are not guaranteed to maintain 100% performance after cleaning.

Filters finer than 40 µm use the disposable elements made of paper or microglass. Filter elements as fine as 5 µm(c) are available; finer filter elements on request.

Eaton filter elements are known as stable elements which have excellent filtration capabilities and a high dirt retaining capacity, therefore having a long service life. Due to its practical design, the return-line filter is easy to service.

Eaton filter can be used for petroleum-based fluids, HW emulsions, water glycols, most synthetic fluids and lubrication fluids. Consult factory for specific fluid applications.

When changing the filter element, a detachable connection between the filter head and the filter bowl prevents dirty oil from flowing into the tank.

Type index:

Complete filter: (ordering example)

TEF. 952. 10VG. 10. S. P. -. FS. A. -.

1	2	3	4	5	6	7	8	9	10
---	---	---	---	---	---	---	---	---	----

E1. O. -. -. -

11	12	13	14	15
----	----	----	----	----

- 1 series:**
TEF = tank-mounted return-line-filter
- 2 nominal size:** 952
- 3 filter-material:**
80G, 40G, 25G stainless steel wire mesh
25VG, 16VG, 10VG, 6VG, 3VG microglass
10P paper
- 4 filter element collapse rating:**
10 = Δp 145 PSI
- 5 filter element design:**
E = without by-pass valve
S = with by-pass valve Δp 29 PSI
S1 = with by-pass valve Δp 51 PSI
- 6 sealing material:**
P = Nitrile (NBR)
V = Viton (FPM)
- 7 filter element specification:**
- = standard
IS06 = for HFC application, see sheet-no. 31601
- 8 process connection:**
FS = SAE-flange 3000 PSI
- 9 process connection size:**
A = 3"
- 10 filter housing specification:**
- = standard
IS06 = for HFC application, see sheet-no. 31605
IS10 = for ATEX, see sheet-no. 68267
IS11 = for mining application, see sheet-no. 40530
- 11 clogging indicator at M1:**
- = without
O = visual, see sheet-no. 1616
E1 = pressure switch, see sheet-no. 1616
E2 = pressure switch, see sheet-no. 1616
E5 = pressure switch, see sheet-no. 1616
PA = ground connection
- 12 clogging indicator at M2:**
possible indicators see position 11 of the type index
- 13 clogging indicator at M3:**
possible indicators see position 11 of the type index
- 14 clogging indicator at M4:**
possible indicators see position 11 of the type index
- 15 discharge pipe:**
- = without
1 = with discharge pipe

To add an indicator to your filter, use the corresponding indicator data sheet to find the indicator details and add them to the filter assembly model code.

1.2. Filter element: (ordering example)

01E. 950. 10VG. 10. S. P. -

1	2	3	4	5	6	7
---	---	---	---	---	---	---

- 1 series:**
01E. = filter element according to company standard
- 2 nominal size:** 950
- 3 - 7** see type index-complete filter

Accessories:

- SAE-counter flange, see sheet-no. 1652

Technical data:

operating temperature:	14 °F to +212 °F
operating medium	mineral oil, other media on request
max. operating pressure:	145 PSI
opening pressure by-pass valve:	29 PSI, 51 PSI
process connection:	SAE-flange 3000 PSI
housing material standard:	filter head and cover AL, / filter bowl glass fiber reinforced polyamide
housing material IS10, category 2 and 3:	filter head and cover AL, / filter bowl carbon fiber reinforced polyamide
housing material IS11, category M2:	filter head and cover GG, / filter bowl carbon fiber reinforced polyamide
sealing material:	Nitrile (NBR) or Viton (FPM), other materials on request
installation position:	vertical
volume tank:	2.60 Gal

Classified under the Pressure Equipment Directive 2014/68/EU for mineral oil (fluid group 2), Article 4, Para. 3.
 Classified under ATEX Directive 2014/34/EU according to specific application (see questionnaire sheet-no. 34279-4).

Pressure drop flow curves:

Filter calculation/sizing

The pressure drop of the assembly at a given flow rate Q is the sum of the housing Δp and the element Δp and is calculated as follows:

$$\Delta p_{assembly} = \Delta p_{housing} + \Delta p_{element}$$

$$\Delta p_{housing} = (\text{see } \Delta p = f(Q) \text{ - characteristics})$$

$$\Delta p_{element} (PSI) = Q (GPM) \times \frac{MSK}{1000} \left(\frac{PSI}{GPM} \right) \times v (SUS) \times \frac{\rho}{0.876} \left(\frac{kg}{dm^3} \right)$$

For ease of calculation our Filter Selection tool is available online at www.eaton.com/hydraulic-filter-evaluation

Material gradient coefficients (MSK) for filter elements

The material gradient coefficients in psi/gpm apply to mineral oil (HLP) with a density of 0.876 kg/dm³ and a kinematic viscosity of 139 SUS (30 mm²/s). The pressure drop changes proportionally to the change in kinematic viscosity and density.

TEF	VG					G			P
	3VG	6VG	10VG	16VG	25VG	25G	40G	80G	10P
952	0.364	0.253	0.162	0.141	0.096	0.0179	0.0167	0.0115	0.076

$\Delta p = f(Q)$ – characteristics according to ISO 3968

The pressure drop characteristics apply to mineral oil (HLP) with a density of 0.876 kg/dm³. The pressure drop changes proportionally to the density.

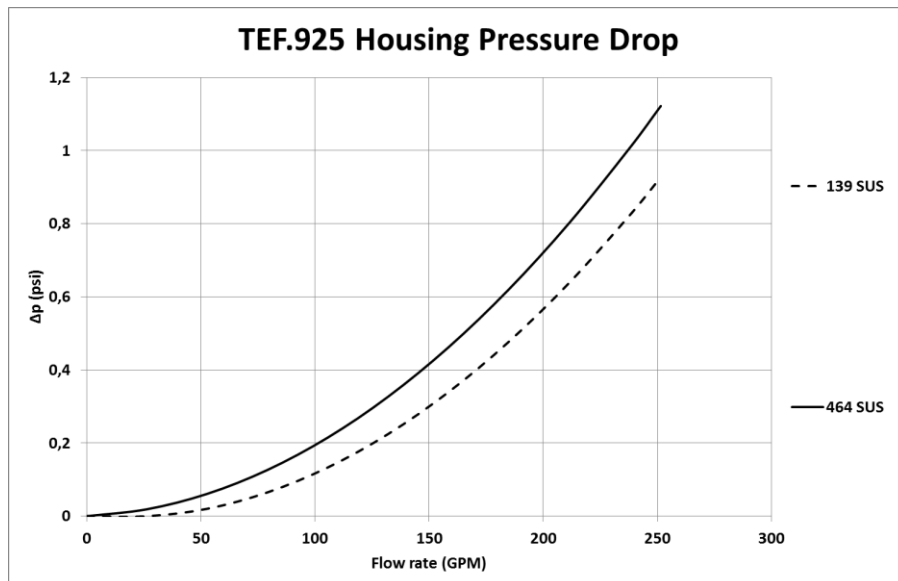

Symbols:

without indicator

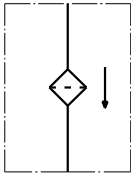

with by-pass valve

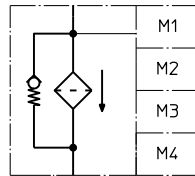

visual O



electric contact maker
E1



electric contact breaker
E5



electric contact maker/breaker
E2



Spare parts:

item	qty.	designation	dimension	article-no.	
1	1	filter element	01.E950...		
2	1	filter head			
3	1	filter cover			
4	1	filter bowl without discharge pipe	NG 950		
	1	filter bowl with discharge pipe	NG 950		
5	1	O-ring	195 x 3,5	301831 (NBR)	306528 (FPM)
6	1	O-ring	170 x 6	304799 (NBR)	306529 (FPM)
7	1	O-ring	190 x 5	305432 (NBR)	310283 (FPM)
8	1	O-ring	78 x 10	305017 (NBR)	305552 (FPM)
9	1	clogging indicator visual	O	301721	
10	1	clogging indicator electric	E1, E2 or E5	see sheet-no. 1616	

Test methods:

Filter elements are tested according to the following ISO standards:

ISO 2941	Verification of collapse/burst resistance
ISO 2942	Verification of fabrication integrity
ISO 2943	Verification of material compatibility with fluids
ISO 3723	Method for end load test
ISO 3724	Verification of flow fatigue characteristics
ISO 3968	Evaluation of pressure drop versus flow characteristics
ISO 16889	Multi-pass method for evaluating filtration performance

North America
44 Apple Street
Tinton Falls, NJ 07724
Toll Free: 800 656-3344
(North America only)
Tel: +1 732 212-4700

Greater China
No. 7, Lane 280,
Linhong Road
Changning District, 200335
Shanghai, P.R. China
Tel: +86 21 5200-0099

Europe/Africa/Middle East
Auf der Heide 2
53947 Nettersheim, Germany
Tel: +49 2486 809-0

Friedensstraße 41
68804 Altlufsheim, Germany
Tel: +49 6205 2094-0

An den Nahewiesen 24
55450 Langenlonsheim, Germany
Tel: +49 6704 204-0

Asia-Pacific
100G Pasir Panjang Road
#07-08 Interlocal Centre
Singapore 118523
Tel: +65 6825-1668

**For more information, please
email us at filtration@eaton.com
or visit www.eaton.com/filtration**

© 2021 Eaton. All rights reserved. All trademarks and registered trademarks are the property of their respective owners. All information and recommendations appearing in this brochure concerning the use of products described herein are based on tests believed to be reliable. However, it is the user's responsibility to determine the suitability for his own use of such products. Since the actual use by others is beyond our control, no guarantee, expressed or implied, is made by Eaton as to the effects of such use or the results to be obtained. Eaton assumes no liability arising out of the use by others of such products. Nor is the information herein to be construed as absolutely complete, since additional information may be necessary or desirable when particular or exceptional conditions or circumstances exist or because of applicable laws or government regulations.