

# Series TEF 4801-7201 DN150-200 PN10

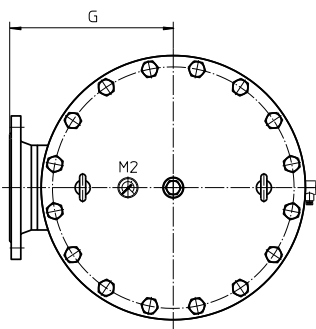
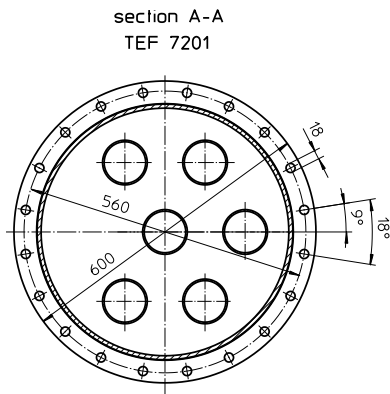
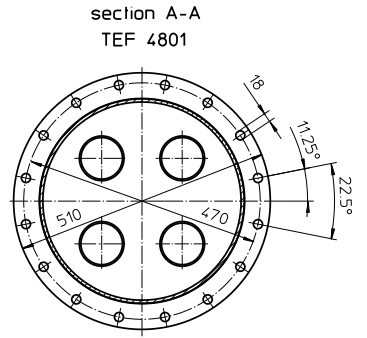
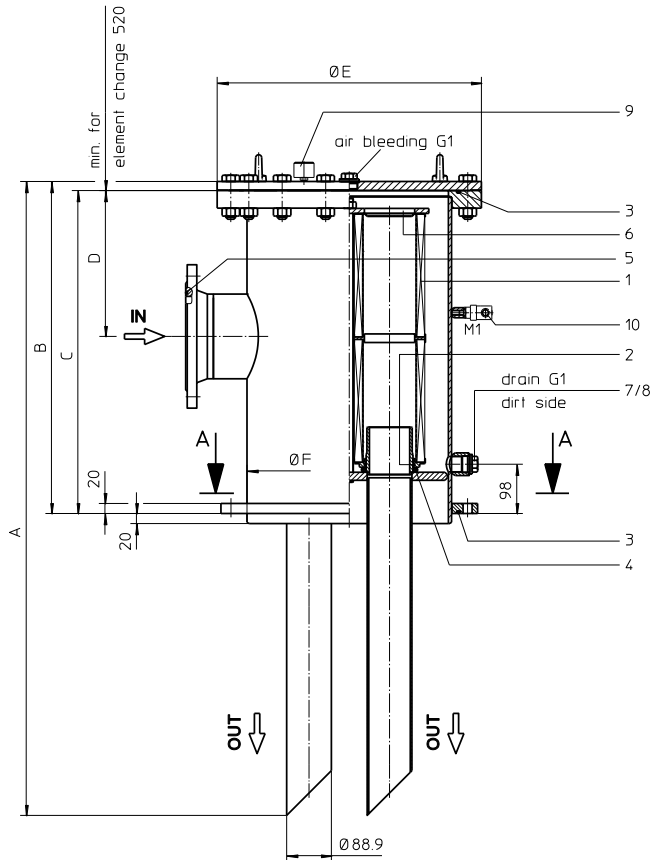

## 2. Dimensions:

type	connection	A	B	C	D	E	F	G	weight kg	Volume tank
TEF 4801	DN150	1260	660	642	290	525	406	325	175	75,0 l
TEF 7201	DN200	1264	664	642	280	615	508	400	252	117,0 l

Dimensions: mm

Designs and performance values are subject to change.

# Return Line Filter

## Series TEF 4801-7201

### DN100-200 PN10

#### Description:

Return-line filter series TEF 4801-7201 have a working pressure up to 10 bar. Pressure peaks will be absorbed by a sufficient margin of safety.

The TEF-filters are directly mounted to the reservoir and connected to the return-line.

The filter element consists of a star-shaped, pleated filter material which is supported on the inside by a perforated core tube and is bonded to the end caps with a high-quality adhesive. The flow is from outside to inside.

For cleaning the stainless steel mesh element (see special leaflets 21070-4 and 39448-4) or changing the filter element, remove the cover and take out the element. The mesh elements are not guaranteed to maintain 100% performance after cleaning.

Filters finer than 40 µm use the disposable elements made of paper or microglass. Filter elements as fine as 5 µm(c) are available; finer filter elements on request.

Eaton filter elements are known as stable elements which have excellent filtration capabilities and a high dirt retaining capacity, therefore having a long service life. Due to its practical design, the return-line filter is easy to service.

Eaton filter can be used for petroleum-based fluids, HW emulsions, water glycols, most synthetic fluids and lubrication fluids. Consult factory for specific fluid applications.

When changing the filter element, a detachable connection between the filter head and the filter bowl prevents dirty oil from flowing into the tank.

#### 1. Type index:

##### 1.1. Complete filter: (ordering example)

**TEF. 4801. 10VG. 10. S. P. -. FD3. D. -. E1. O**

1	2	3	4	5	6	7	8	9	10	11	12
---	---	---	---	---	---	---	---	---	----	----	----

##### 1 series:

TEF = tank-mounted return-line-filter

##### 2 nominal size: 4801, 7201

##### 3 filter-material:

80G, 40G, 25G stainless steel wire mesh  
25VG, 16VG, 10VG, 6VG, 3VG microglass  
10P paper

##### 4 filter element collapse rating:

10 = Δp 10 bar

##### 5 filter element design:

E = without by-pass valve  
S = with by-pass valve Δp 2,0 bar

##### 6 sealing material:

P = Nitrile (NBR)  
V = Viton (FPM)

##### 7 filter element specification:

- = standard  
IS06 = for HFC application, see sheet-no. 31601

##### 8 process connection:

FD3 = flange EN1092-1, PN16 with O-ring nut (TEF 4801)  
FD13 = flange EN1092-1, PN10 with O-ring nut (TEF 7201)

##### 9 process connection size:

D = DN150 (TEF 4801)  
E = DN200 (TEF 7201)

##### 10 filter housing specification:

- = standard  
IS06 = for HFC application, see sheet-no. 31605

##### 11 clogging indicator at M1:

- = without  
O = visual, see sheet-no. 1616  
E1 = pressure switch, see sheet-no. 1616  
E2 = pressure switch, see sheet-no. 1616  
E5 = pressure switch, see sheet-no. 1616

##### 12 clogging indicator at M2:

possible indicators see position 11 of the type index

To add an indicator to your filter, use the corresponding indicator data sheet to find the indicator details and add them to the filter assembly model code.

##### 1.2. Filter element: (ordering example)

**01E. 1201. 10VG. 10. S. P. -**

1	2	3	4	5	6	7
---	---	---	---	---	---	---

##### 1 series:

01E. = filter element according to company standard

##### 2 nominal size: 1201

##### 3 - 7 see type index-complete filter

## Technical data:

operating temperature:	-10°C to +100°C
operating medium	mineral oil, other media on request
max. operating pressure:	10 bar
opening pressure by-pass valve:	2,0 bar
process connection:	flange EN1092-1, PN16 / PN10
housing material:	carbon steel
sealing material:	Nitrile (NBR) or Viton (FPM), other materials on request
installation position:	vertical

Classified under the Pressure Equipment Directive 2014/68/EU for mineral oil (fluid group 2), Article 4, Para. 3.  
 Classified under ATEX Directive 2014/34/EU according to specific application (see questionnaire sheet-no. 34279-4).

## Pressure drop flow curves:

### Filter calculation/sizing

The pressure drop of the assembly at a given flow rate Q is the sum of the housing  $\Delta p$  and the element  $\Delta p$  and is calculated as follows:

$$\Delta p_{assembly} = \Delta p_{housing} + \Delta p_{element}$$

$$\Delta p_{housing} = (\text{see } \Delta p = f(Q) \text{ - characteristics})$$

$$\Delta p_{element} \text{ (mbar)} = Q \left( \frac{l}{min} \right) \times \frac{MSK \text{ (mbar)} \cdot v \left( \frac{mm^2}{s} \right)}{10 \left( \frac{l}{min} \right)} \times \frac{\rho \text{ (kg)} \cdot v \left( \frac{mm^2}{s} \right)}{0,876 \left( \frac{kg}{dm^3} \right)}$$

For ease of calculation our Filter Selection tool is available online at [www.eaton.com/hydraulic-filter-evaluation](http://www.eaton.com/hydraulic-filter-evaluation)

### Material gradient coefficients (MSK) for filter elements

The material gradient coefficients in mbar/(l/min) apply to mineral oil (HLP) with a density of 0,876 kg/dm<sup>3</sup> and a kinematic viscosity of 30 mm<sup>2</sup>/s (139 SUS). The pressure drop changes proportionally to the change in kinematic viscosity and density.

TEF	VG					G			P
	3VG	6VG	10VG	16VG	25VG	25G	40G	80G	10P
<b>4801</b>	0,06	0,042	0,027	0,023	0,016	0,0019	0,0018	0,0012	0,013
<b>7201</b>	0,04	0,028	0,018	0,016	0,011	0,0013	0,0012	0,0008	0,008

### $\Delta p = f(Q)$ – characteristics according to ISO 3968

The pressure drop characteristics apply to mineral oil (HLP) with a density of 0,876 kg/dm<sup>3</sup>. The pressure drop changes proportionally to the density.

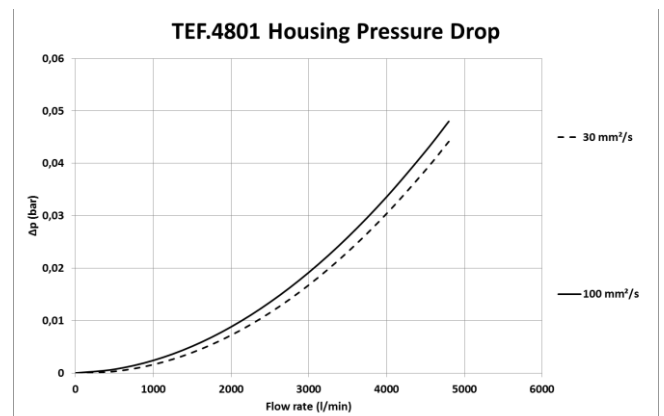
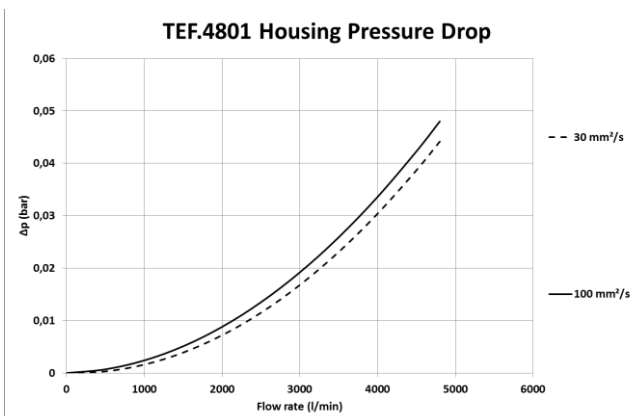

## Symbols:

without indicator

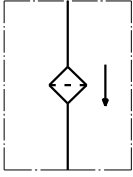

with by-pass valve

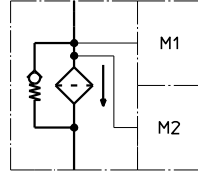

visual O



electric contact maker  
E1



electric contact breaker  
E5



electric contact maker/breaker  
E2



## Spare parts:

item	designation	qty.	dimension and article no. TEF 4801	qty.	dimension and article no. TEF 7201
1	filter element	4	01E.1201...	6	01E.1201...
2	O-ring	4	93 x 5 307588 (NBR) 307589 (FPM)	6	93 x 5 307588 (NBR) 307589 (FPM)
3	O-ring	2	429 x 6 308659 (NBR) 310273 (FPM)	2	516 x 6 301962 (NBR) 311474 (FPM)
4	O-ring	4	85 x 10 304386 (NBR) 304541 (FPM)	6	85 x 10 304386 (NBR) 304541 (FPM)
5	O-ring	1	170 x 4 306875 (NBR) 307987 (FPM)	1	225 x 5 308652 (NBR) 311473 (FPM)
6	pressure plate	1	319677	1	327718
7	screw plug	2		G 1 309732	
8	gasket	2		A 33 x 39 308257	
9	clogging indicator visual	1		O see sheet no.. 1616	
10	clogging indicator electric	1		E1, E2 or E5 see sheet no.. 1616	

## Test methods:

Filter elements are tested according to the following ISO standards:

ISO 2941	Verification of collapse/burst resistance
ISO 2942	Verification of fabrication integrity
ISO 2943	Verification of material compatibility with fluids
ISO 3723	Method for end load test
ISO 3724	Verification of flow fatigue characteristics
ISO 3968	Evaluation of pressure drop versus flow characteristics
ISO 16889	Multi-pass method for evaluating filtration performance

**North America**  
44 Apple Street  
Tinton Falls, NJ 07724  
Toll Free: 800 656-3344  
(North America only)  
Tel: +1 732 212-4700

**Greater China**  
No. 7, Lane 280,  
Linhong Road  
Changning District, 200335  
Shanghai, P.R. China  
Tel: +86 21 5200-0099

**Europe/Africa/Middle East**  
Auf der Heide 2  
53947 Nettersheim, Germany  
Tel: +49 2486 809-0  
Friedensstraße 41  
68804 Altlußheim, Germany  
Tel: +49 6205 2094-0

**Asia-Pacific**  
100G Pasir Panjang Road  
#07-08 Interlocal Centre  
Singapore 118523  
Tel: +65 6825-1668

An den Nahewiesen 24  
55450 Langenlonsheim, Germany  
Tel: +49 6704 204-0

**For more information, please  
email us at [filtration@eaton.com](mailto:filtration@eaton.com)  
or visit [www.eaton.com/filtration](http://www.eaton.com/filtration)**

© 2021 Eaton. All rights reserved. All trademarks and registered trademarks are the property of their respective owners. All information and recommendations appearing in this brochure concerning the use of products described herein are based on tests believed to be reliable. However, it is the user's responsibility to determine the suitability for his own use of such products. Since the actual use by others is beyond our control, no guarantee, expressed or implied, is made by Eaton as to the effects of such use or the results to be obtained. Eaton assumes no liability arising out of the use by others of such products. Nor is the information herein to be construed as absolutely complete, since additional information may be necessary or desirable when particular or exceptional conditions or circumstances exist or because of applicable laws or government regulations.