

Series DTEF 120 DN25 PN10

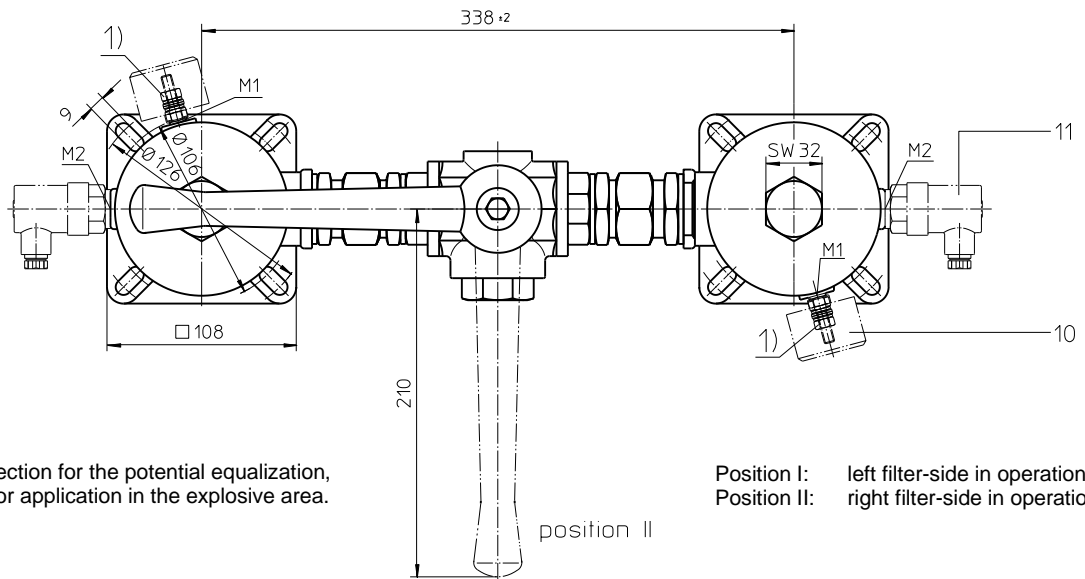
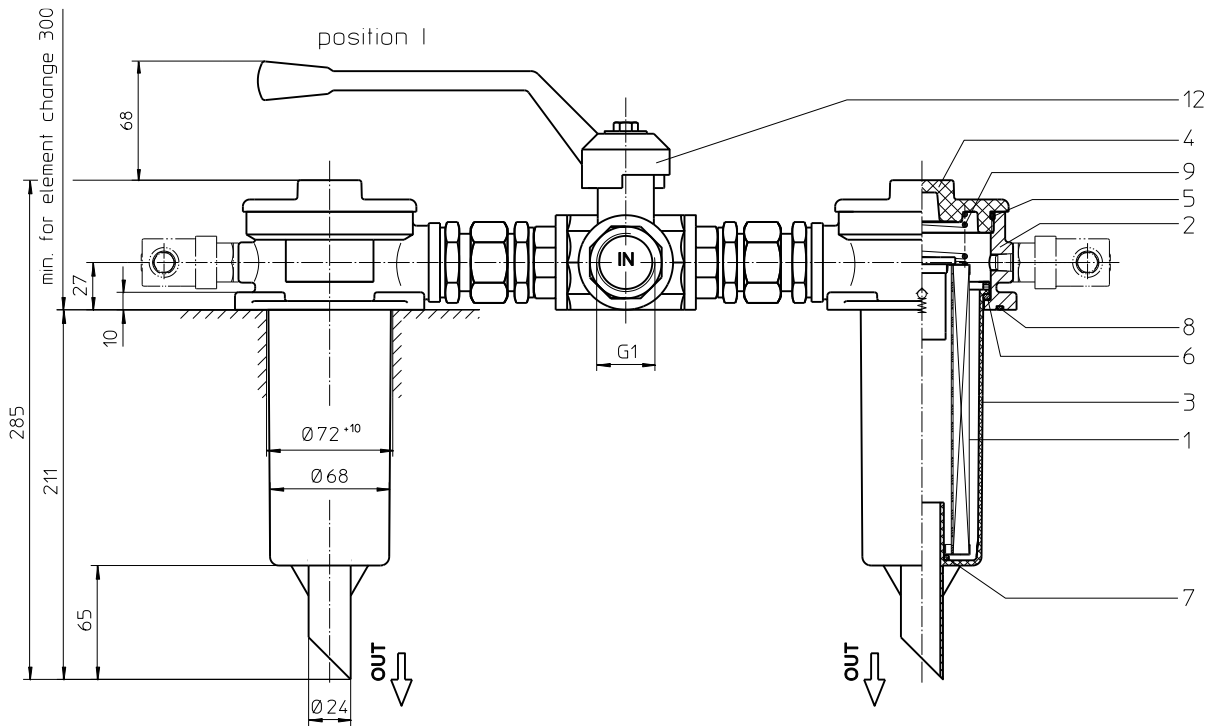

Weight: approx. 4,0 kg

Dimensions: mm

Designs and performance values are subject to change.



Powering Business Worldwide

Return Line Filter

Series DTEF 120

DN25 PN10

Description:

Return-line filter series DTEF 120 have a working pressure up to 10 bar. Pressure peaks will be absorbed by a sufficient margin of safety.

The DTEF-filters are directly mounted to the reservoir and connected to the return-line.

A three way changeover valve which is integrated in the middle of the housing makes it possible to switch from the dirty filter-side to the clean filter-side without interrupting operation.

The filter element consists of a star-shaped, pleated filter material which is supported on the inside by a perforated core tube and is bonded to the end caps with a high-quality adhesive. The flow is from outside to inside.

For cleaning the stainless steel mesh element (see special leaflets 21070-4 and 39448-4) or changing the filter element, remove the cover and take out the element. The mesh elements are not guaranteed to maintain 100% performance after cleaning.

For filtration finer than 40 µm use the disposable elements made of paper or microglass. Filter elements as fine as 5 µm(c) are available; finer filter elements on request.

Eaton filter elements are known as stable elements which have excellent filtration capabilities and a high dirt retaining capacity, therefore having a long service life.

Eaton filter can be used for petroleum-based fluids, HW emulsions, water glycols, most synthetic fluids and lubrication fluids. Consult factory for specific fluid applications.

When changing the filter element, a detachable connection between the filter head and the filter bowl prevents dirty oil from flowing into the tank.

1. Type index:

1.1. Complete filter: (ordering example)

DTEF. 120. 10VG. 16. S. P. - . G. 5. - . O. E1

1	2	3	4	5	6	7	8	9	10	11	12
---	---	---	---	---	---	---	---	---	----	----	----

- 1 series:**
DTEF = tank-mounted return-line-filter, change over
- 2 nominal size:** 120
- 3 filter-material:**
80G, 40G, 25G stainless steel wire mesh
25VG, 16VG, 10VG, 6VG, 3VG microglass
10P paper
- 4 filter element collapse rating:**
16 = Δp 16 bar
- 5 filter element design:**
E = without by-pass valve
S = with by-pass valve Δp 2,0 bar
S1 = with by-pass valve Δp 3,5 bar
- 6 sealing material:**
P = Nitrile (NBR)
V = Viton (FPM)
- 7 filter element specification: (see catalog)**
- = standard
IS06 = for HFC application, see sheet-no. 31601
- 8 process connection:**
G = thread connection according to DIN 3852, T2
- 9 process connection size:**
5 = G1
- 10 filter housing specification: (see catalog)**
- = standard
IS06 = for HFC application, see sheet-no. 31605
IS10 = for ATEX, see sheet-no. 68267
- 11 clogging indicator at M1:**
- = without
O = visual, see sheet-no. 1616
E1 = pressure switch, see sheet-no. 1616
E2 = pressure switch, see sheet-no. 1616
E5 = pressure switch, see sheet-no. 1616
- 12 clogging indicator at M2:**
possible indicators see position 11 of the type index

To add an indicator to your filter, use the corresponding indicator data sheet to find the indicator details and add them to the filter assembly model code.

1.2. Filter element: (ordering example)

01E. 120. 10VG. 16. S. P. -

1	2	3	4	5	6	7
---	---	---	---	---	---	---

- 1 series:**
01E. = filter element according to company standard
- 2 nominal size:** 120
- 3 - 7** see type index-complete filter

Technical data:

operating temperature:	-10°C to +100°C
operating medium	mineral oil, other media on request
max. operating pressure:	10 bar
opening pressure by-pass valve:	2,0 bar / 3,5 bar
process connection:	thread connection according to DIN 3852, T2
housing material standard:	filter head AL, screw plug / filter bowl glass fiber reinforced polyamide
housing material IS10, category 2 and 3:	filter head AL, screw plug / filter bowl carbon fiber reinforced polyamide)
sealing material:	Nitrile (NBR) or Viton (FPM), other materials on request
installation position:	vertical
volume tank:	2x 0,6 l

Classified under the Pressure Equipment Directive 2014/68/EU for mineral oil (fluid group 2), Article 4, Para. 3.
 Classified under ATEX Directive 2014/34/EU according to specific application (see questionnaire sheet-no. 34279-4).

Pressure drop flow curves:

Filter calculation/sizing

The pressure drop of the assembly at a given flow rate Q is the sum of the housing Δp and the element Δp and is calculated as follows:

$$\Delta p_{assembly} = \Delta p_{housing} + \Delta p_{element}$$

$$\Delta p_{housing} = (\text{see } \Delta p = f(Q) \text{ - characteristics})$$

$$\Delta p_{element} \text{ (mbar)} = Q \left(\frac{l}{min} \right) \times \frac{MSK \text{ (mbar)}}{10 \text{ (l/min)}} \times v \left(\frac{mm^2}{s} \right) \times \frac{\rho \text{ (kg)}}{0,876 \text{ (dm}^3)}$$

For ease of calculation our Filter Selection tool is available online at www.eaton.com/hydraulic-filter-evaluation

Material gradient coefficients (MSK) for filter elements

The material gradient coefficients in mbar/(l/min) apply to mineral oil (HLP) with a density of 0,876 kg/dm³ and a kinematic viscosity of 30 mm²/s (139 SUS). The pressure drop changes proportionally to the change in kinematic viscosity and density.

DTEF	VG					G			P
	3VG	6VG	10VG	16VG	25VG	25G	40G	80G	10P
120	2,624	1,821	1,166	1,015	0,694	0,0934	0,0872	0,0597	0,564

$\Delta p = f(Q)$ – characteristics according to ISO 3968

The pressure drop characteristics apply to mineral oil (HLP) with a density of 0.876 kg/dm³. The pressure drop changes proportionally to the density.

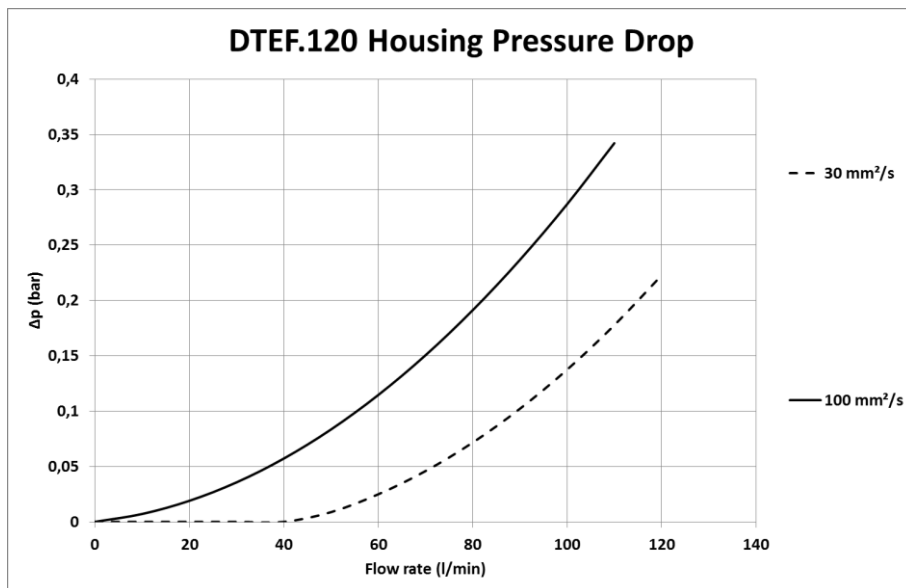

Symbols:

without indicator

with by-pass valve

visual O

electric
contact maker
E1

electric
contact breaker
E5

electric
contact maker/breaker
E2

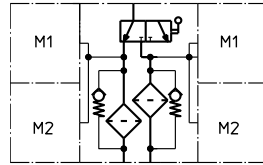
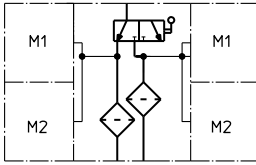

Spare parts:

item	qty.	designation	dimension	article-no.	
1	2	filter element	01.E120...		
2	2	filter head			
3	2	filter bowl			
4	2	screw plug	M 82 x 2		
5	2	O-ring	75 x 3	302215 (NBR)	304729 (FPM)
6	2	O-ring	68 x 4	303037 (NBR)	313046 (FPM)
7	2	O-ring	24 x 3	303038 (NBR)	304397 (FPM)
8	4	O-ring	86 x 3	305470 (NBR)	313047 (FPM)
9	2	spring	DA = 52	304982	
10	2	clogging indicator, visual	O	see sheet-no. 1616	
11	2	pressure switch, electric	E1, E2 or E5	see sheet-no. 1616	
12	1	three-way-change-over valve		308115	

Test methods:

Filter elements are tested according to the following ISO standards:

ISO 2941	Verification of collapse/burst resistance
ISO 2942	Verification of fabrication integrity
ISO 2943	Verification of material compatibility with fluids
ISO 3723	Method for end load test
ISO 3724	Verification of flow fatigue characteristics
ISO 3968	Evaluation of pressure drop versus flow characteristics
ISO 16889	Multi-pass method for evaluating filtration performance

North America
44 Apple Street
Tinton Falls, NJ 07724
Toll Free: 800 656-3344
(North America only)
Tel: +1 732 212-4700

Greater China
No. 7, Lane 280,
Linhong Road
Changning District, 200335
Shanghai, P.R. China
Tel: +86 21 5200-0099

Europe/Africa/Middle East
Auf der Heide 2
53947 Nettersheim, Germany
Tel: +49 2486 809-0
Friedensstraße 41
68804 Altlußheim, Germany
Tel: +49 6205 2094-0

Asia-Pacific
100G Pasir Panjang Road
#07-08 Interlocal Centre
Singapore 118523
Tel: +65 6825-1668

**For more information, please
email us at filtration@eaton.com
or visit www.eaton.com/filtration**

© 2021 Eaton. All rights reserved. All trademarks and registered trademarks are the property of their respective owners. All information and recommendations appearing in this brochure concerning the use of products described herein are based on tests believed to be reliable. However, it is the user's responsibility to determine the suitability for his own use of such products. Since the actual use by others is beyond our control, no guarantee, expressed or implied, is made by Eaton as to the effects of such use or the results to be obtained. Eaton assumes no liability arising out of the use by others of such products. Nor is the information herein to be construed as absolutely complete, since additional information may be necessary or desirable when particular or exceptional conditions or circumstances exist or because of applicable laws or government regulations.