

# Series TSW 625

- mounting surface 1
- surface quality  $.12 \mu\text{in}$
- flatness tolerance  $\square$  .01"

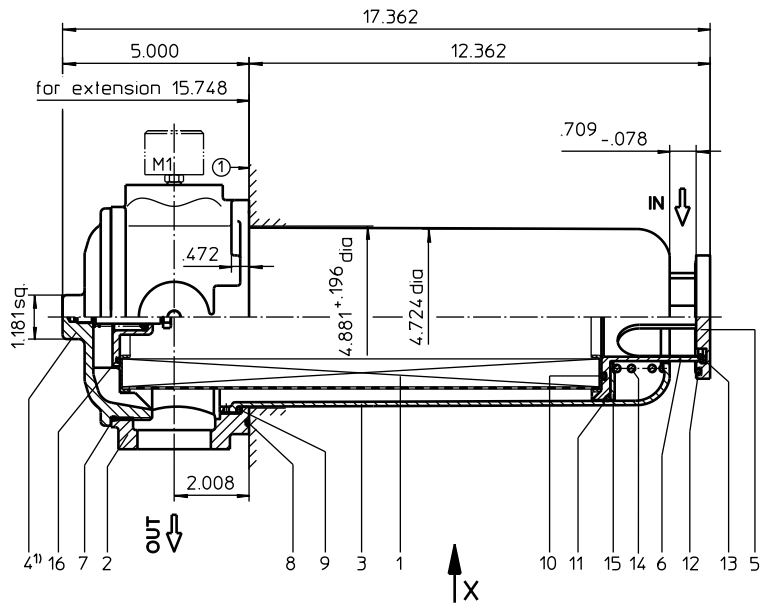
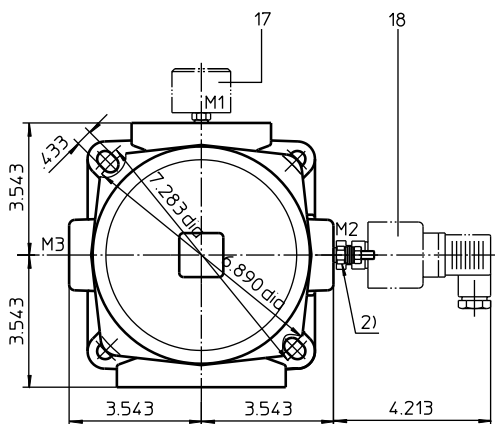
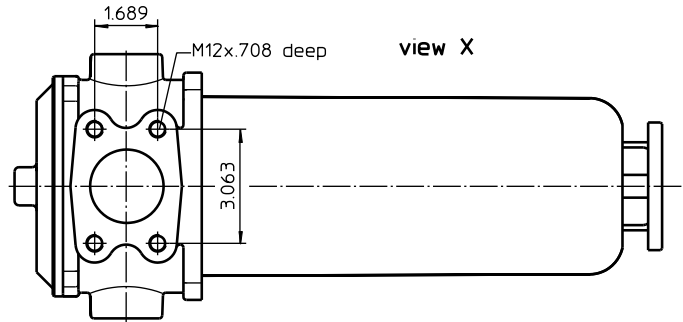

2) Connection for the potential equalization, only for application in the explosive area.

1) The bypass valve is integrated in the screw plug. For the filter without a by-pass valve the opening function is raised up to  $\Delta p > 14.5 \text{ PSI}$ .

Weight approx.: 12 lbs.

Dimensions: inches

Designs and performance values are subject to change!

# Suction Filter

## Series TSW 625

### Description:

The TSW-filters are directly mounted to the reservoir and connected to the suction-line.

The filter element consists of a star-shaped folded bellows, which is flowed through from the inside to the outside.

For cleaning the mesh element or changing the microglass element, remove the cover and take out the element. The mesh elements are not guaranteed to maintain 100% performance after cleaning

Filters finer than 40 µm use the disposable elements made of paper or microglass. Filter elements as fine as 5 µm(c) are available; finer filter elements on request.

Eaton filter elements are known as stable elements which have excellent filtration capabilities and a high dirt retaining capacity, therefore having a long service life. Due to its practical design, the return-line filter is easy to service.

Eaton filter can be used for petroleum-based fluids, HW emulsions, water glycols, most synthetic fluids and lubrication fluids. Consult factory for specific fluid applications.

Due to its practical design, the return-line filter is easy to service. When releasing the filter cover a plate-shaped valve closes the suction-inlet of the filter bowl and prevents the return flow of dirt oil into the reservoir. For cleaning, the filter bowl together with the filter element can be taken out of the filter head.

### Type index:

**Complete filter:** (ordering example)

<b>TSW. 625. 10VG. - . B. P. - . FS. 8. - . - O1. E4.-0,25. -</b>													
1	2	3	4	5	6	7	8	9	10	11	12	13	14

- 1 | **series:**  
TSW = suction filter for horizontal tank-mounting
- 2 | **nominal size:** 625
- 3 | **filter material:**  
80G, 40G, 25G stainless steel wire mesh  
25VG, 16VG, 10VG, 6VG, 3VG microglass  
10P paper
- 4 | **filter element collapse rating:**  
- = not specified
- 5 | **filter element design:**  
B = both sides open
- 6 | **sealing material:**  
P = Nitrile (NBR)  
V = Viton (FPM)
- 7 | **filter element specification:**  
- = standard  
VA = stainless steel
- 8 | **process connection:**  
FS = SAE-flange connection 3000 PSI
- 9 | **process connection size:**  
8 = 2"
- 10 | **filter housing specification:**  
- = standard  
IS11 = for mining applications, see sheet-no. 40530
- 11 | **internal valve:**  
- = without  
S = with by-pass valve Δp 4.1 PSI
- 12 | **clogging indicator at M1:**  
- = without  
O1 = visual, see sheet-no. 1616  
E4.-0,25 = pressure switch, see sheet-no. 1616  
PA = potential equalization
- 13 | **clogging indicator at M2:**  
possible indicators see position 12 of the type index
- 14 | **clogging indicator at M3:**  
possible indicators see position 12 of the type index

To add an indicator to your filter, use the corresponding indicator data sheet to find the indicator details and add them to the filter assembly model code.

**Filter element:** (ordering example)

<b>01TS. 625. 10VG. - . B. - . -</b>						
1	2	3	4	5	6	7

- 1 | **series:**  
01TS. = suction filter element according to company standard
- 2 | **nominal size:** 625
- 3 | - 5 | , 7 | see type index-complete filter
- 6 | **sealing material:**  
- = without

## Technical data:

operating temperature:	+14°F to +212°F
operating medium	mineral oil, other media on request
process connection:	SAE-flange connection 3000 PSI
housing material standard:	filter head / filter cover AL / filter bowl glass fiber reinforced polyamide
housing material IS11/category M2:	filter head / filter cover GG / filter bowl carbon fiber reinforced polyamide
sealing material:	Nitrile (NBR) or Viton (FPM), other materials on request
installation position:	horizontal
volume tank:	1.1 Gal.

Classified under the Pressure Equipment Directive 2014/68/EU for mineral oil (fluid group 2), Article 4, Para. 3.  
 Classified under ATEX Directive 2014/34/EU according to specific application (see questionnaire sheet-no. 34279-4).

## Pressure drop flow curves:

### Filter calculation/sizing

The pressure drop of the assembly at a given flow rate Q is the sum of the housing  $\Delta p$  and the element  $\Delta p$  and is calculated as follows:

$$\Delta p_{assembly} = \Delta p_{housing} + \Delta p_{element}$$

$$\Delta p_{housing} = (\text{see } \Delta p = f(Q) \text{ - characteristics})$$

$$\Delta p_{element} (PSI) = Q (GPM) \times \frac{MSK}{1000} \left( \frac{PSI}{GPM} \right) \times \nu (SUS) \times \frac{\rho}{0.876} \left( \frac{kg}{dm^3} \right)$$

For ease of calculation our Filter Selection tool is available online at [www.eaton.com/hydraulic-filter-evaluation](http://www.eaton.com/hydraulic-filter-evaluation)

### Material gradient coefficients (MSK) for filter elements

The material gradient coefficients in psi/gpm apply to mineral oil (HLP) with a density of 0.876 kg/dm<sup>3</sup> and a kinematic viscosity of 139 SUS (30 mm<sup>2</sup>/s). The pressure drop changes proportionally to the change in kinematic viscosity and density.

TSW	VG					G			P
	3VG	6VG	10VG	16VG	25VG	25G	40G	80G	10P
625	0.733	0.509	0.326	0.284	0.194	0.0170	0.0159	0.0109	0.160

### $\Delta p = f(Q)$ – characteristics according to ISO 3968

The pressure drop characteristics apply to mineral oil (HLP) with a density of 0.876 kg/dm<sup>3</sup>. The pressure drop changes proportionally to the density.

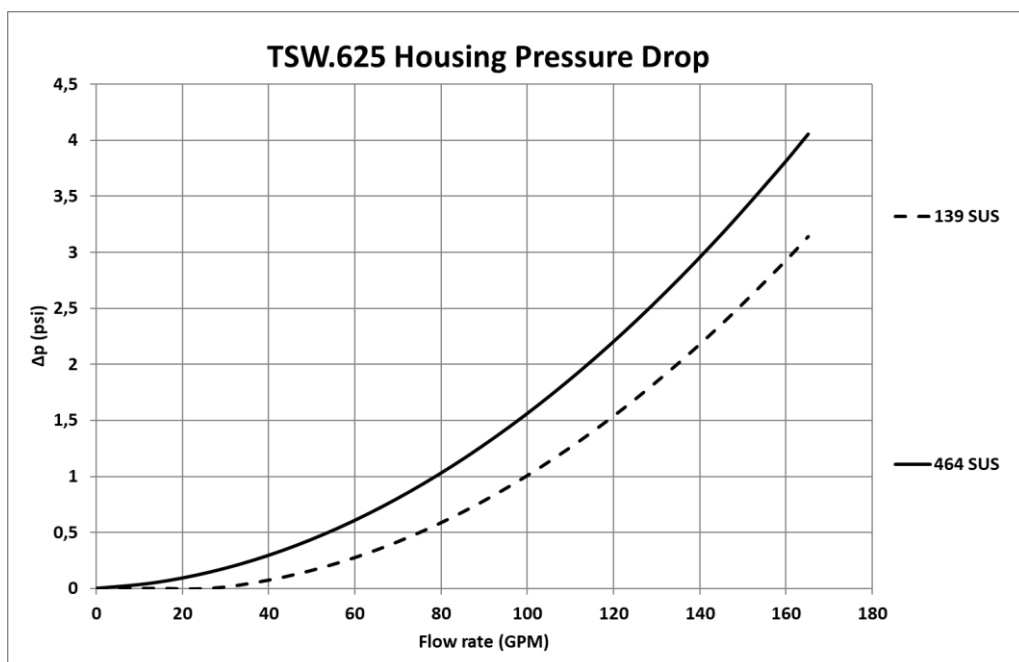

## Symbols:

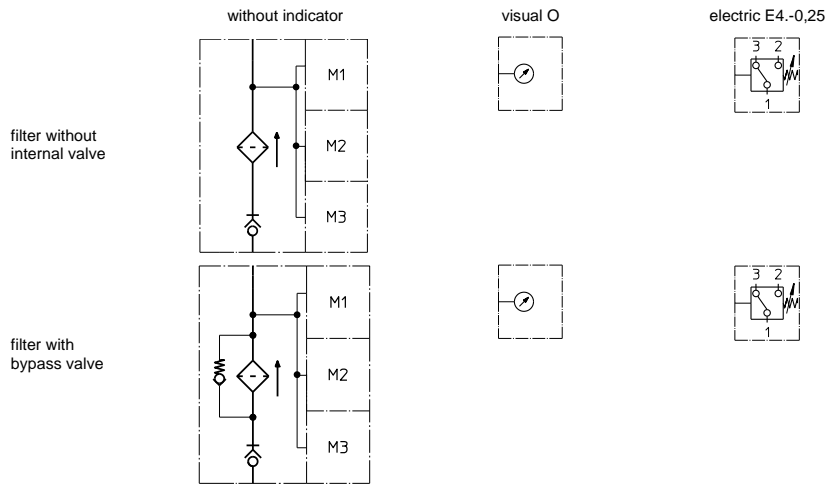

## Spare parts:

item	qty.	designation	dimensions	Article-no.	
1	1	filter element	01TS.625...		
2	1	filter head	NG 625		
3	1	filter bowl	NG 625		
4	1	filter cover without/with bypass valve	M 140 x 3		
5	1	valve disc		318740	
6	1	valve bushing		318739	
7	1	O-ring	135 x 3,5	318386 (NBR)	318387 (FPM)
8	1	O-ring	140 x 3	304604 (NBR)	307514 (FPM)
9	1	O-ring	120 x 4	305300 (NBR)	307991 (FPM)
10	1	O-ring	76 x 4	305599 (NBR)	310291 (FPM)
11	1	O-ring	104,37 x 3,53	304339 (NBR)	304390 (FPM)
12	1	O-ring	70 x 4	306253 (NBR)	310280 (FPM)
13	1	sliding ring	B55	311976	
14	1	pressure spring	5,0 x 70 x 117 x 3,5	318742	
15	1	disc		318741	
16	1	O-ring	50 x 3	307398 (NBR)	314682 (FPM)
17	1	clogging indicator, visual	O1	301722	
18	1	pressure switch, electric	E4.-0,25	301725	

## Test methods:

Filter elements are tested according to the following ISO standards:

ISO 2941	Verification of collapse/burst resistance
ISO 2942	Verification of fabrication integrity
ISO 2943	Verification of material compatibility with fluids
ISO 3723	Method for end load test
ISO 3724	Verification of flow fatigue characteristics
ISO 3968	Evaluation of pressure drop versus flow characteristics
ISO 16889	Multi-pass method for evaluating filtration performance

**North America**  
44 Apple Street  
Tinton Falls, NJ 07724  
Toll Free: 800 656-3344  
(North America only)  
Tel: +1 732 212-4700

**Greater China**  
No. 7, Lane 280,  
Linhong Road  
Changning District, 200335  
Shanghai, P.R. China  
Tel: +86 21 5200-0099

**Europe/Africa/Middle East**  
Auf der Heide 2  
53947 Nettersheim, Germany  
Tel: +49 2486 809-0

**Asia-Pacific**  
100G Pasir Panjang Road  
#07-08 Interlocal Centre  
Singapore 118523  
Tel: +65 6825-1668

Friedensstraße 41  
68804 Altlußheim, Germany  
Tel: +49 6205 2094-0

An den Nahewiesen 24  
55450 Langenlonsheim, Germany  
Tel: +49 6704 204-0

**For more information, please  
email us at [filtration@eaton.com](mailto:filtration@eaton.com)  
or visit [www.eaton.com/filtration](http://www.eaton.com/filtration)**

© 2021 Eaton. All rights reserved. All trademarks and registered trademarks are the property of their respective owners. All information and recommendations appearing in this brochure concerning the use of products described herein are based on tests believed to be reliable. However, it is the user's responsibility to determine the suitability for his own use of such products. Since the actual use by others is beyond our control, no guarantee, expressed or implied, is made by Eaton as to the effects of such use or the results to be obtained. Eaton assumes no liability arising out of the use by others of such products. Nor is the information herein to be construed as absolutely complete, since additional information may be necessary or desirable when particular or exceptional conditions or circumstances exist or because of applicable laws or government regulations.