

Series TS 210-310 DN32

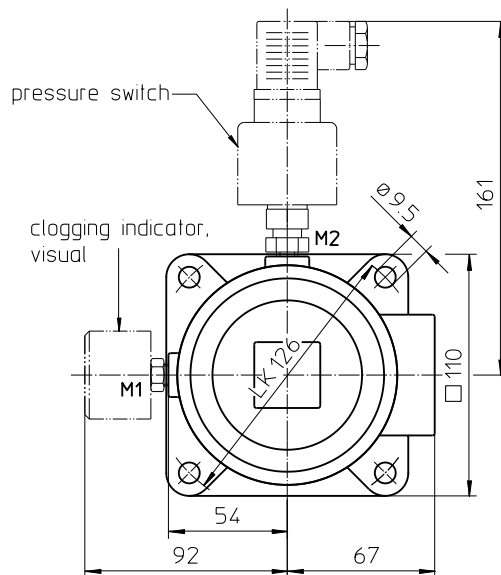
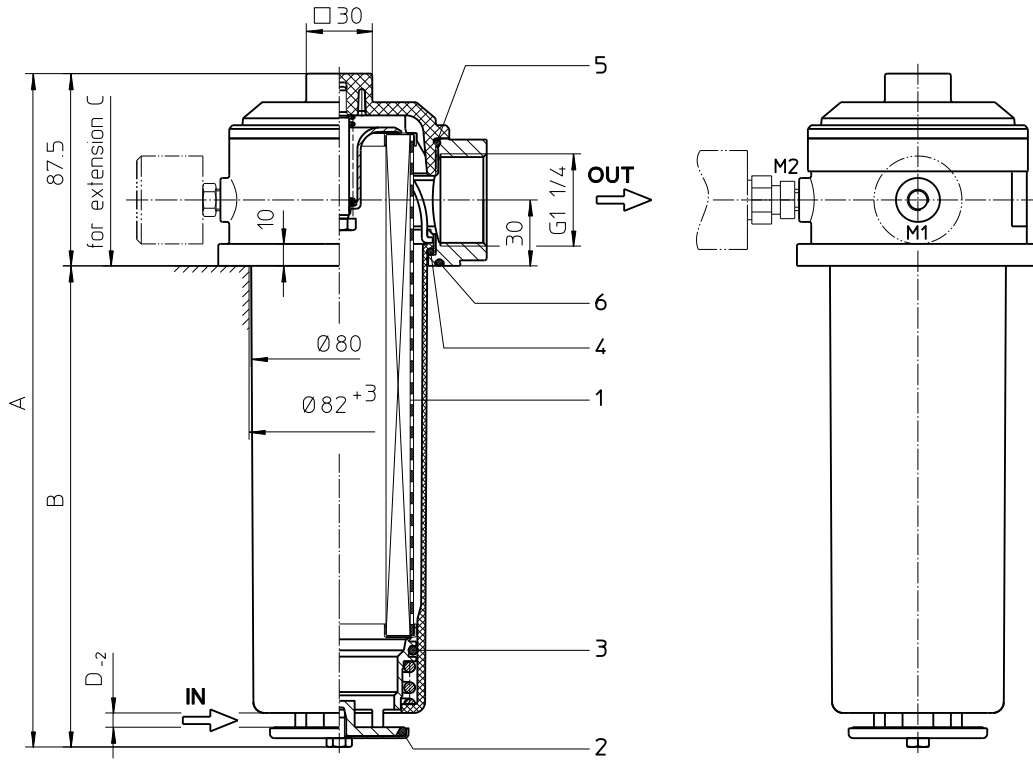

Dimensions:

type	TS 210	TS 310
connection	G 1 ¼	G 1 ¼
A	307	393
B	219	305
C	290	375
D	6,5	7,5
weight	1,6 kg	1,8 kg
volume tank	1,1 l	1,5 l

Dimensions: mm

Designs and performance values are subject to change!

Suction Filter

Series TS 210-310

DN32

Description:

The TS-filters are directly mounted to the reservoir and connected to the suction-line. The suction-area „IN“ must be below the oil level.

The filter element consists of a star-shaped folded bellows, which is flowed through from the inside to the outside.

For cleaning the stainless steel mesh element (see special leaflets 21070-4 and 39448-4) or changing the filter element, remove the cover and take out the element. The mesh elements are not guaranteed to maintain 100% performance after cleaning.

Filters finer than 40 µm use the disposable elements made of paper or microglass. Filter elements as fine as 5 µm(c) are available; finer filter elements on request.

Eaton filter elements are known as stable elements which have excellent filtration capabilities and a high dirt retaining capacity, therefore having a long service life. Due to its practical design, the return-line filter is easy to service.

Eaton filter can be used for petroleum-based fluids, HW emulsions, water glycols, most synthetic fluids and lubrication fluids. Consult factory for specific fluid applications.

Due to its practical design, the return-line filter is easy to service. When releasing the filter cover a plate-shaped valve closes the suction-inlet of the filter bowl and prevents the return flow of dirt oil into the reservoir. For cleaning, the filter bowl together with the filter element can be taken out of the filter head.

Type index:

Complete filter: (ordering example)

TS. 210. 10VG. -. B. P. -. G. 6. -. -. O1. E4.-0,25

1	2	3	4	5	6	7	8	9	10	11	12	13
---	---	---	---	---	---	---	---	---	----	----	----	----

- 1 series:**
TS = suction filter for vertical tank-mounting
- 2 nominal size:** 210, 310
- 3 filter material:**
80G, 40G, 25G stainless steel wire mesh
25VG, 16VG, 10VG, 6VG, 3VG microglass
10P paper
- 4 filter element collapse rating:**
- = not specified
- 5 filter element design:**
B = both sides open
- 6 sealing material:**
P = Nitrile (NBR)
V = Viton (FPM)
- 7 filter element specification:**
- = standard
- 8 process connection:**
G = thread connection according to DIN 3852, T2
- 9 process connection size:**
6 = G 1 ¼
- 10 filter housing specification:**
- = standard
- 11 internal valve:**
- = without
S = with by-pass valve Δp 0,28 bar
- 12 clogging indicator at M1:**
- = without
O1 = visual, see sheet-no. 1616
E4.-0,25 = pressure switch, see sheet-no. 1616
- 13 clogging indicator at M2:**
possible indicators see position 12 of the type index

To add an indicator to your filter, use the corresponding indicator data sheet to find the indicator details and add them to the filter assembly model code.

Filter element: (ordering example)

01TS. 210. 10VG. -. B. -. -

1	2	3	4	5	6	7
---	---	---	---	---	---	---

- 1 series:**
01TS. = suction filter element according to company standard
- 2 nominal size:** 210, 310
- 3 - 5, 7** see type index-complete filter
- 6 sealing material:**
- = without

Technical data:

operating temperature:	-10°C to +100°C
operating medium	mineral oil, other media on request
process connection:	thread connection according to DIN 3852, T2
housing material standard:	AL-casting, filter cover / filter bowl glass fiber reinforced polyamide
sealing material:	Nitrile (NBR) or Viton (FPM), other materials on request
installation position:	vertical

Classified under the Pressure Equipment Directive 2014/68/EU for mineral oil (fluid group 2), Article 4, Para. 3.
 Classified under ATEX Directive 2014/34/EU according to specific application (see questionnaire sheet-no. 34279-4).

Pressure drop flow curves:

Filter calculation/sizing

The pressure drop of the assembly at a given flow rate Q is the sum of the housing Δp and the element Δp and is calculated as follows:

$$\Delta p_{assembly} = \Delta p_{housing} + \Delta p_{element}$$

$$\Delta p_{housing} = (\text{see } \Delta p = f(Q) - \text{characteristics})$$

$$\Delta p_{element} (mbar) = Q \left(\frac{l}{min} \right) \times \frac{MSK (mbar)}{10} \left(\frac{l}{min} \right) \times v \left(\frac{mm^2}{s} \right) \times \frac{p}{0,876} \left(\frac{kg}{dm^3} \right)$$

For ease of calculation our Filter Selection tool is available online at www.eaton.com/hydraulic-filter-evaluation

Material gradient coefficients (MSK) for filter elements

The material gradient coefficients in mbar/(l/min) apply to mineral oil (HLP) with a density of 0,876 kg/dm³ and a kinematic viscosity of 30 mm²/s (139 SUS). The pressure drop changes proportionally to the change in kinematic viscosity and density.

TS	VG					G			P
	3VG	6VG	10VG	16VG	25VG	25G	40G	80G	10P
210	1,867	1,296	0,830	0,722	0,494	0,0500	0,0467	0,0320	0,362
310	1,351	0,938	0,600	0,523	0,357	0,0362	0,0338	0,0231	0,262

$\Delta p = f(Q)$ – characteristics according to ISO 3968

The pressure drop characteristics apply to mineral oil (HLP) with a density of 0,876 kg/dm³. The pressure drop changes proportionally to the density.

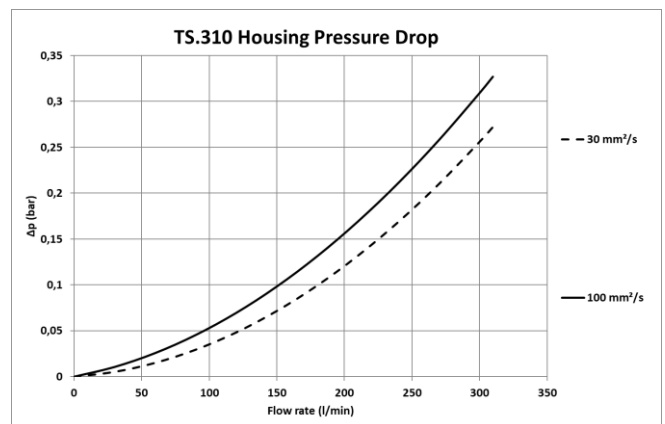
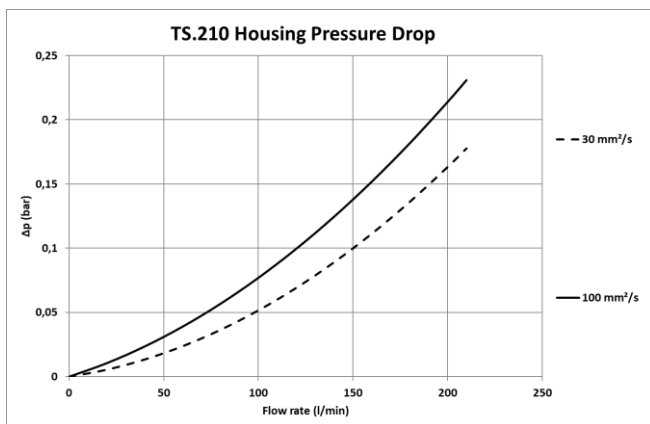

Symbols:

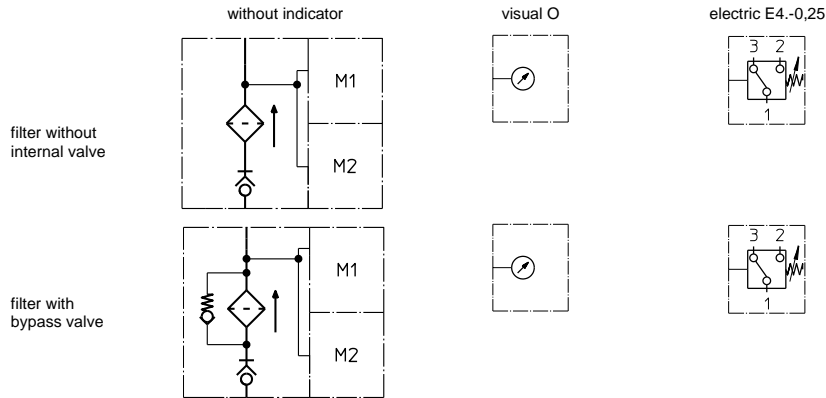

Spare parts:

item	qty.	designation	dimensions		article-no.	
			TS 210	TS 310		
1	1	filter element	01TS. 210...	01TS. 310...		
2	1	O-ring	53 x 4		309143 (NBR)	332434 (FPM)
3	1	O-ring	62 x 4		308045 (NBR)	311472 (FPM)
4	1	O-ring	75 x 3		302215 (NBR)	304729 (FPM)
5	1	O-ring	82 x 3		305191 (NBR)	305298 (FPM)
6	1	O-ring	88 x 3		304417 (NBR)	310266 (FPM)

Test methods:

Filter elements are tested according to the following ISO standards:

ISO 2941	Verification of collapse/burst resistance
ISO 2942	Verification of fabrication integrity
ISO 2943	Verification of material compatibility with fluids
ISO 3723	Method for end load test
ISO 3724	Verification of flow fatigue characteristics
ISO 3968	Evaluation of pressure drop versus flow characteristics
ISO 16889	Multi-pass method for evaluating filtration performance

North America
 44 Apple Street
 Tinton Falls, NJ 07724
 Toll Free: 800 656-3344
 (North America only)
 Tel: +1 732 212-4700

Greater China
 No. 7, Lane 280,
 Linhong Road
 Changning District, 200335
 Shanghai, P.R. China
 Tel: +86 21 5200-0099

Europe/Africa/Middle East
 Auf der Heide 2
 53947 Nettersheim, Germany
 Tel: +49 2486 809-0

Asia-Pacific
 100G Pasir Panjang Road
 #07-08 Interlocal Centre
 Singapore 118523
 Tel: +65 6825-1668

Friedensstraße 41
 68804 Altlußheim, Germany
 Tel: +49 6205 2094-0
 An den Nahewiesen 24
 55450 Langenlonsheim, Germany
 Tel: +49 6704 204-0

**For more information, please
 email us at filtration@eaton.com
 or visit www.eaton.com/filtration**

© 2021 Eaton. All rights reserved. All trademarks and registered trademarks are the property of their respective owners. All information and recommendations appearing in this brochure concerning the use of products described herein are based on tests believed to be reliable. However, it is the user's responsibility to determine the suitability for his own use of such products. Since the actual use by others is beyond our control, no guarantee, expressed or implied, is made by Eaton as to the effects of such use or the results to be obtained. Eaton assumes no liability arising out of the use by others of such products. Nor is the information herein to be construed as absolutely complete, since additional information may be necessary or desirable when particular or exceptional conditions or circumstances exist or because of applicable laws or government regulations.