

# Series NF 1000 DN50-65 PN16

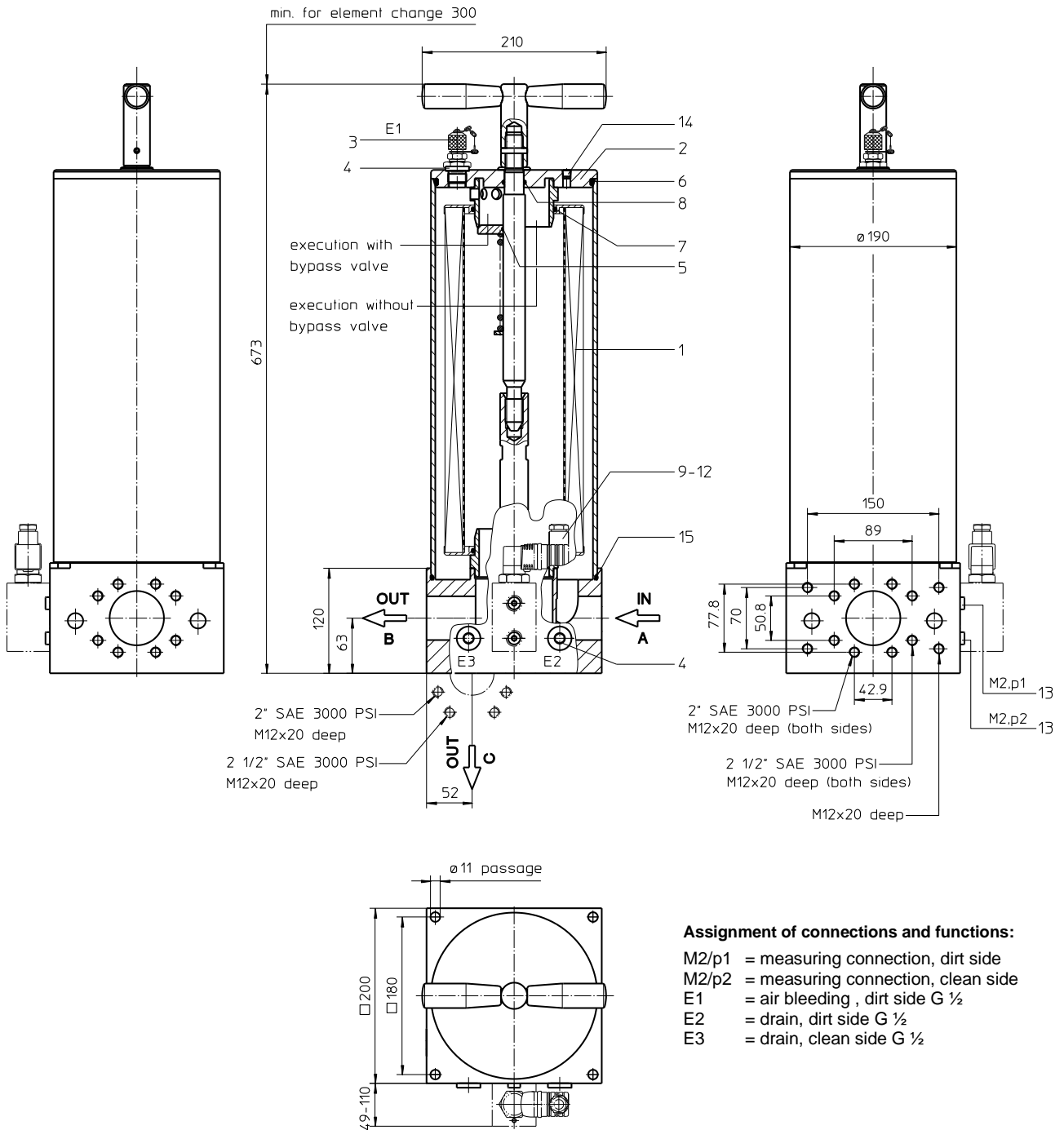

Weight: approx. 20 kg

Dimensions: mm

Designs and performance values are subject to change.

# Offline Filter

## Series NF 1000

### DN50-65 PN16

#### Description:

The offline filter NF 1000 is foreseen for the fine filtration of hydraulic and lubrication circuits additionally to the main filter.

The big filtration area in comparison to the nominal size is the premise for a high dirt-retaining capacity even in case of small filter-fineness. The filter NF is flanged mounted to the line.

Filter elements as fine as 5  $\mu\text{m}_{(c)}$  are available; finer filter elements on request. Element change without tools is possible. After release of the straining screw and removal of the cover the elements are accessible and could be changed.

The filter elements were delivered completely inclusive seals. Cleaning of the elements not possible therefore the user should have enough spare elements on stock.

Eaton filter elements are known for high intrinsic stability and an excellent filtration capability, a high dirt-retaining capacity and a long service life.

The internal valve is integrated in the filter cover. After reaching the bypass pressure setting, the bypass valve will send unfiltered partial flow around the filter.

#### Type index:

**Complete filter:** (ordering example)

<b>NF.</b>	<b>1000.</b>	<b>10VG.</b>	<b>10.</b>	<b>B.</b>	<b>P.</b>	<b>-.</b>	<b>FS.</b>	<b>3.</b>	<b>-.</b>	<b>-.</b>	<b>AE</b>
1	2	3	4	5	6	7	8	9	10	11	12

- 1 series:**  
NF = offline filter
- 2 nominal size:** 1000
- 3 filter-material:**  
25VG, 16VG, 10VG, 6VG, 3VG microglass  
10WVG, 3WVG watersorp-filter element
- 4 filter element collapse rating:**  
10 =  $\Delta p$  10 bar
- 5 filter element design:**  
B = both sides open
- 6 sealing material:**  
P = Nitrile (NBR)  
V = Viton (FPM)
- 7 filter element specification:**  
- = standard  
VA = stainless steel  
IS06 = for HFC applications, see sheet-no. 31601
- 8 process connection:**  
FS = SAE-flange connection 3000 PSI
- 9 number of connection variant:**

variant	process connection		
	A connection size	B connection size	C connection size
1	8	8	-
2	8	8	8
3	9	9	-
4	9	9	9

connection size: 8 = 2"  
9 = 2 1/2"  
- = without connection

- 10 filter housing specification:**  
- = standard  
IS06 = for HFC applications, see sheet-no. 31605
- 11 internal valve:**  
- = without  
S1 = with bypass valve  $\Delta p$  3,5 bar
- 12 clogging indicator or clogging sensor:**  
- = without  
AE = visual-electric, see sheet-no. 1609  
OP = visual, see sheet-no. 1628  
OE = visual-electric, see sheet-no. 1628  
VS5 = electronic, see sheet-no. 1641

To add an indicator/sensor to your filter, use the corresponding indicator data sheet to find the indicator details and add them to the filter assembly model code.

**Filter element:** (ordering example)

<b>01NR.</b>	<b>1000.</b>	<b>10VG.</b>	<b>10.</b>	<b>B.</b>	<b>P.</b>	<b>-</b>
1	2	3	4	5	6	7

- 1 series:**  
01NR = standard return line filter element according to DIN 24550, part 4
- 2 nominal size:** 630
- 3 - 7** see type index-complete filter

#### Accessories:

- gauge port- and bleeder connection, see sheet-no. 1650
- drain- and bleeder connection, see sheet-no. 1651
- SAE-counter flanges, see sheet-no. 1652

## Technical data:

operating temperature:	-10°C bis +100°C
operating medium	mineral oil, other media on request
max. operating pressure:	16 bar
test pressure:	23 bar
process connection:	SAE-flange connection 3000 PSI
housing material:	aluminium forging alloy
sealing material:	Nitrile (NBR) or Viton (FPM), other materials on request
installation position:	vertical
measure connection:	G ½ (mini-measuring)
drain- and bleeder connections:	G ½
volume tank:	11,4 l

Classified under the Pressure Equipment Directive 2014/68/EU for mineral oil (fluid group 2), Article 4, Para. 3.  
 Classified under ATEX Directive 2014/34/EU according to specific application (see questionnaire sheet-no. 34279-4).

## Filter calculation/sizing

The pressure drop of the assembly at a given flow rate Q is the sum of the housing  $\Delta p$  and the element  $\Delta p$  and is calculated as follows:

$$\Delta p_{assembly} = \Delta p_{housing} + \Delta p_{element}$$

$$\Delta p_{housing} = (\text{see } \Delta p = f(Q) - \text{characteristics})$$

$$\Delta p_{element} (mbar) = Q \left( \frac{l}{min} \right) \times \frac{MSK (mbar)}{10 \left( \frac{l}{min} \right)} \times \nu \left( \frac{mm^2}{s} \right) \times \frac{p}{0,876} \left( \frac{kg}{dm^3} \right)$$

For ease of calculation our Filter Selection tool is available online at  
[www.eaton.com/hydraulic-filter-evaluation](http://www.eaton.com/hydraulic-filter-evaluation)

## Material gradient coefficients (MSK) for filter elements

The material gradient coefficients in mbar/(l/min) apply to mineral oil (HLP) with a density of 0,876 kg/dm<sup>3</sup> and a kinematic viscosity of 30 mm<sup>2</sup>/s (139 SUS). The pressure drop changes proportionally to the change in kinematic viscosity and density.

NF	VG				
	3VG/3WVG	6VG	10VG/10WVG	16VG	25VG
1000	0,197	0,137	0,087	0,076	0,052

## $\Delta p = f(Q)$ – characteristics according to ISO 3968

The pressure drop characteristics apply to mineral oil (HLP) with a density of 0,876 kg/dm<sup>3</sup>. The pressure drop changes proportionally to the density.

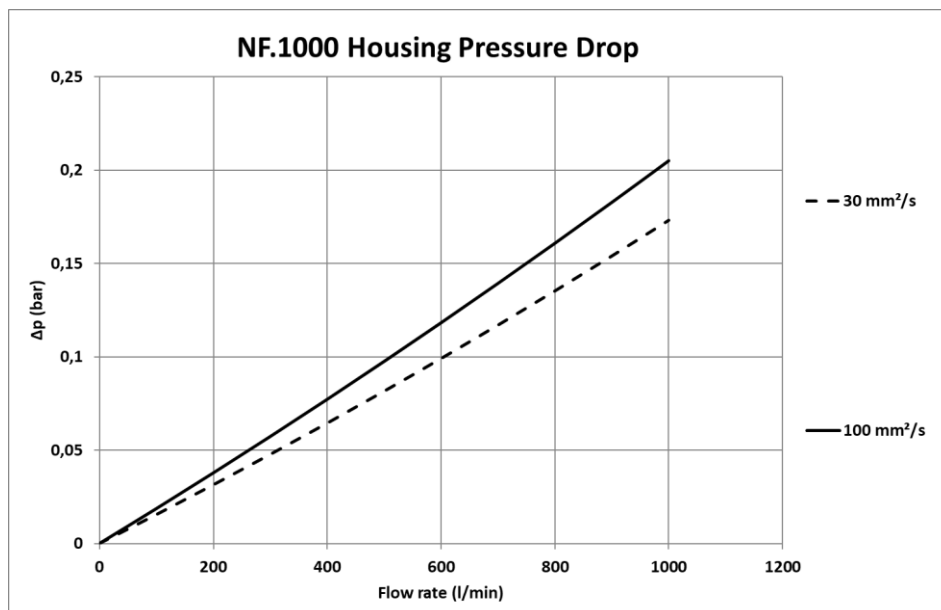

## Symbols:

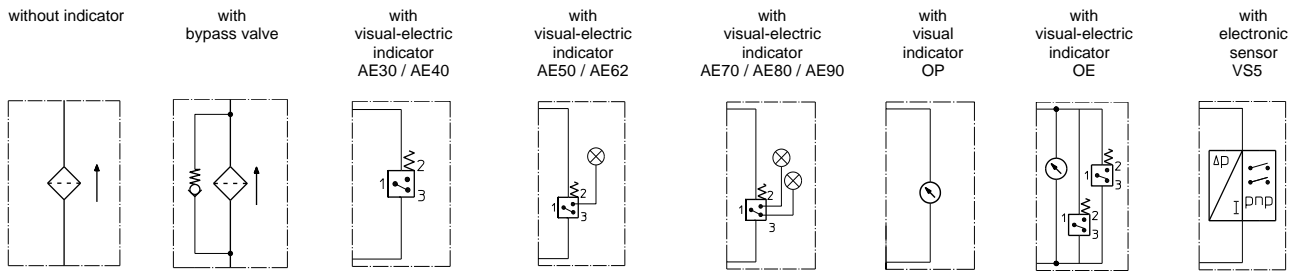

## Spare parts:

item	qty.	designation	dimension	article-no.
1	1	filter element	01NR.1000...	
2	1	filter cover without bypass valve	31065-3	
	1	filter cover with bypass valve S1	31461-3	
3	1	mini-measuring connection	MA.3.ST	308630
4	3	screw plug	G ½	304678
5	1	O-ring (only with bypass valve)	22 x 3	304387 (NBR)   304931 (FPM)
6	1	O-ring	170 x 6	304799 (NBR)   306529 (FPM)
7	2	O-ring	90 x 4	306941 (NBR)   307031 (FPM)
8	1	O-ring	22 x 3	304387 (NBR)   304931 (FPM)
9	1	clogging indicator, visual	OP	see sheet-no. 1628
10	1	clogging indicator, visual-electric	OE	see sheet-no. 1628
11	1	clogging indicator, visual-electric	AE	see sheet-no. 1609
12	1	clogging sensor, electronic	VS5	see sheet-no. 1641
13	2	screw plug	G 1/8	304791
14	1	screw plug	G 1/8	305496
15	1	O-ring	183 x 4	337003 (NBR)   337004 (FPM)

item 13 execution only without clogging indicator or clogging sensor

## Test methods:

Filter elements are tested according to the following ISO standards:

ISO 2941	Verification of collapse/burst resistance
ISO 2942	Verification of fabrication integrity
ISO 2943	Verification of material compatibility with fluids
ISO 3723	Method for end load test
ISO 3724	Verification of flow fatigue characteristics
ISO 3968	Evaluation of pressure drop versus flow characteristics
ISO 16889	Multi-pass method for evaluating filtration performance

**North America**  
 44 Apple Street  
 Tinton Falls, NJ 07724  
 Toll Free: 800 656-3344  
 (North America only)  
 Tel: +1 732 212-4700

**Grater China**  
 No. 7, Lane 280,  
 Linhong Road  
 Changning District, 200335  
 Shanghai, P.R. China  
 Tel: +86 21 5200-0099

**Europe/Africa/Middle East**  
 Auf der Heide 2  
 53947 Nettersheim, Germany  
 Tel: +49 2486 809-0

Friedensstraße 41  
 68804 Altlußheim, Germany  
 Tel: +49 6205 2094-0

An den Nahewiesen 24  
 55450 Langenlonsheim, Germany  
 Tel: +49 6704 204-0

**Asia-Pacific**  
 100G Pasir Panjang Road  
 #07-08 Interlocal Centre  
 Singapore 118523  
 Tel: +65 6825-1668

**For more information, please  
 email us at [filtration@eaton.com](mailto:filtration@eaton.com)  
 or visit [www.eaton.com/filtration](http://www.eaton.com/filtration)**

© 2021 Eaton. All rights reserved. All trademarks and registered trademarks are the property of their respective owners. All information and recommendations appearing in this brochure concerning the use of products described herein are based on tests believed to be reliable. However, it is the user's responsibility to determine the suitability for his own use of such products. Since the actual use by others is beyond our control, no guarantee, expressed or implied, is made by Eaton as to the effects of such use or the results to be obtained. Eaton assumes no liability arising out of the use by others of such products. Nor is the information herein to be construed as absolutely complete, since additional information may be necessary or desirable when particular or exceptional conditions or circumstances exist or because of applicable laws or government regulations.