

PRESSURE FILTER, change-over
Series LF 1201-10001 DN 50-250 PN 16

Sheet No.
1118 M

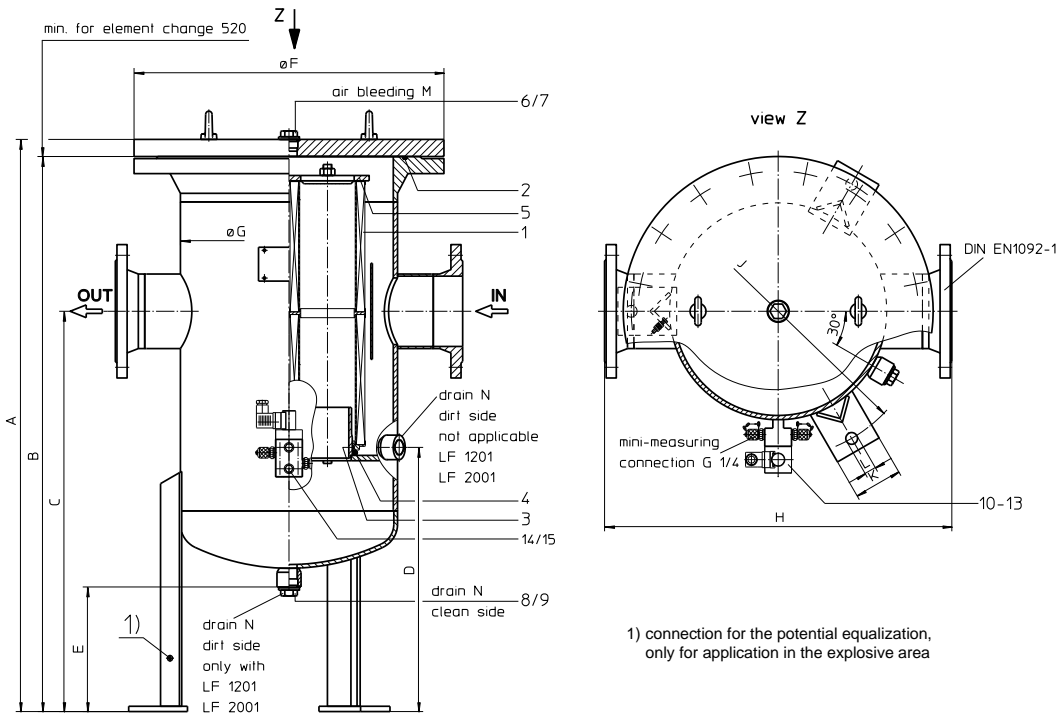

1) connection for the potential equalization, only for application in the explosive area

3. Dimensions:

type	connection DN	A	B	C	D	E	F	G	H	J	K	L	M	N	weight kg	volume tank
LF 1201	50	1052	1028	400	-	188	340	219	412	330	70	18	G 1/2	G1	60	26,0 l
	65	1071	1047													27,0 l
	80	1052	1028													26,0 l
	100	1128	1104													29,0 l
LF 2001	65	1093	1067	425	-	186	405	273	494	380	70	18	G1	G1	110	43,5 l
	80	1112	1086													44,5 l
	100	1100	1074													43,5 l
	125	1188	1162													48,0 l
LF 2401	65	1018	990	700	445	183	460	324	600	450	70	18	G1	G1	130	55,0 l
	80															
	100															
	125															
LF 3601	80	1072	1040	750	495	238	580	406	650	550	90	22	G1	G1	260	90,0 l
	100															
	125															
	150															
LF 4801 LF 6001	100	1116	1080	800	535	232	715	508	800	650	90	22	G1	G1	310	145,0 l
	125															
	150															
	200															
LF9001	125	1366	1330	925	535	232	715	508	800	650	90	22	G1	G1	365	365,0 l
	150															
LF 10001	125	1150	1110	800	570	283	910	711	1000	900	120	22	G1 1/2	G1 1/2	560	283,0 l
	150															
	200															
	250															

1. Type index:

1.1. Complete filter: (ordering example)

LF. 2001. 10VG. 10. E. P. -. FD1. 9. -. AE

1	2	3	4	5	6	7	8	9	10	11
---	---	---	---	---	---	---	---	---	----	----

- 1) **series:**
LF = in-line filter
- 2) **nominal size:** 1201, 2001, 2401, 3601, 4001, 4801, 6001, 9001, 10001
- 3) **filter material and filter fineness:**
80 G = 80 µm, 40 G = 40 µm, 25 G = 25 µm stainless steel wire mesh,
25 VG = 20 µm_(c), 16 VG = 15 µm_(c), 10 VG = 10 µm_(c), 6 VG = 7 µm_(c), 3 VG = 5 µm_(c) glass fibre
25 API = 20 µm, 10 API = 10 µm glass fibre according to API
10 P = 10 µm paper
- 4) **resistance of pressure difference for filter element:**
10 = Δp 10 bar
- 5) **filter element design:**
E = without by-pass valve
S = with by-pass valve Δp 2,0 bar
- 6) **sealing material:**
P = Nitrile (NBR); V = Viton (FPM)
- 7) **filter element specification:**
- = standard
VA = stainless steel
IS06 = for HFC application, see sheet-no. 31601
- 8) **process connection:**
FD1 = flange connection DIN EN1092-1, design B1
FD2 = flange connection DIN EN1092-1, design B2
- 9) **process connection size:**

DN	filter nominal size									
8 = 50	1201									
9 = 65	1201	2001	2401							
A = 80	1201	2001	2401	3601						
B = 100	1201	2001	2401	3601	4801	6001				
C = 125		2001	2401	3601	4801	6001	9001	10001		
D = 150				3601	4801	6001	9001	10001		
E = 200					4801	6001		10001		
F = 250								10001		

- 10) **filter housing specification:**
- = standard
IS06 = for HFC application, see sheet-no. 31605
- 11) **clogging indicator or clogging sensor:**
- = without
OP = visual, see sheet-no.1628; VS5 = electronic, see sheet-no.1641
AE = visual-electric, see sheet-no.1609
OE = visual-electric, see sheet-no 1628

1.2. Filter element: (ordering example)

01E. 2001. 10VG. 10. E. P. -

1	2	3	4	5	6	7
---	---	---	---	---	---	---

- 1) **series:**
01E. = filter element according to company standard
- 2) **nominal size:** 1201, 2001, 3001
- 3) - 7] see type index-complete filter

2. Accessories:

- measure-and bleeder -connections, see sheet-no. 1650
- evacuation- and bleeder-connections, see sheet-no. 1651
- counter flanges, see sheet-no. 1653
- lifting mechanism, see sheet-no. 1661

Changes of measures and design are subject to alteration!



Friedensstrasse 41, 68804 Altlussheim, Germany

phone +49 - (0)6205 - 2094-0 e-mail filtration@eaton.com
 fax +49 - (0)6205 - 2094-40 url www.eaton.com/filtration

4. Spare parts:

4.1. Depending on different series:

item	designation	qty.	dimension and article-no. LF 1201	dimension and article-no. LF 2001	qty.	dimension and article-no. LF 2401	qty.	dimension and article-no. LF 3601	qty.	dimension and article-no. LF 4801	qty.	dimension and article-no. LF 6001	qty.	dimension and article-no. LF 9001	qty.	dimension and article-no. LF 10001	
1	filter element	1	01E.1201	01E.2001	2	01E.1201	3	01E.1201	4	01E.1201	3	01E.2001	3	01E.3001	5	01E.2001	
2	O-ring	1	225 x 5 308652 (NBR) 311473 (FPM)	275 x 5 307414 (NBR) 310288 (FPM)	1	330 x 5 303080 (NBR) 310275 (FPM)	1	429 x 6 308659 (NBR) 310273 (FPM)	1	516 x 6 301962 (NBR) 311474 (FPM)	1	516 x 6 301962 (NBR) 311474 (FPM)	1	516 x 6 301962 (NBR) 311474 (FPM)	5	722 x 8 308145 (NBR) 311805 (FPM)	
3	O-ring	1	93 x 5 307588 (NBR) 307589 (FPM)	135 x 5 306016 (NBR) 307045 (FPM)	2	93 x 5 307588 (NBR) 307589 (FPM)	3	93 x 5 307588 (NBR) 307589 (FPM)	4	93 x 5 307588 (NBR) 307589 (FPM)	3	135 x 5 306016 (NBR) 307045 (FPM)	3	135 x 5 306016 (NBR) 307045 (FPM)	5	135 x 5 306016 (NBR) 307045 (FPM)	
4	O-ring	1	85 x 10 304386 (NBR) 304541 (FPM)	125 x 10 304388 (NBR) 306006 (FPM)	2	85 x 10 304386 (NBR) 304541 (FPM)	3	85 x 10 304386 (NBR) 304541 (FPM)	4	85 x 10 304386 (NBR) 304541 (FPM)	3	125 x 10 304388 (NBR) 306006 (FPM)	3	125 x 10 304388 (NBR) 306006 (FPM)	5	125 x 10 304388 (NBR) 306006 (FPM)	
5	spring	1	304414			-	-	-	-	-	-	-	-	-	-	-	
	pressure plate	-	-			1	309851	1	313116	1	314718	1	313335	1	313335	1	313062
6	screw plug	1	G ½ 309730	G 1 309732	1	G1 309732			G1 309732			G 1 ½ 318556					
7	gasket	1	A 22 x 27 305564	A 33 x 39 308257	1	A 33 x 39 308257			A 33 x 39 308257			A 48 x 55 309764					
8	screw plug	1	G1 309732	G1 309732	2	G1 309732			G1 309732			G 1 ½ 318556					
9	gasket	1	A 33 x 39 308257	A 33 x 39 308257	2	A 33 x 39 308257			A 33 x 39 308257			A 48 x 55 309764					

4.2. Depending on the series:

item	qty.	designation	dimension	article-no.
10	1	clogging indicator, visual	OP	see sheet-no. 1628
11	1	clogging indicator, visual-electric	OE	see sheet-no. 1628
12	1	clogging indicator, visual-electric	AE	see sheet-no. 1609
13	1	clogging sensor, electronic	VS5	see sheet-no. 1641
14	2	screw plug	G ¼	309734
15	2	gasket	A 14 x 18	306330

5. Description:

In-line filters of the series LF 1201-10001 are suitable for a working pressure up to 16 bar. Pressure peaks can be absorbed with a sufficient margin of safety. The filter is in-line mounted. Inlet and outlet are on the same level. The filters can be installed as suction-filter, pressure-filter or return-line filter. The filter element consist of star-shaped, pleated filter material which is supported on the inside by a perforated core tube and is bonded to the end caps with a high-quality adhesive. The flow direction is from outside to the inside. The particles are hold back on the outside. For cleaning (see special leaflet 21070-4 resp. 39448-4) the mesh element respectively to change the glass fibre element remove the cover and take out the element. Filter finer than 40 µm should use throw-away elements made of paper or glass fibre. Filter elements as fine as 5 µm_(c) are available; finer filter elements on request. Eaton filter elements are known as elements with a high intrinsic stability and an excellent filtration capability, a high dirt-retaining capacity and a long service life. Eaton filter are suitable for all petroleum based fluids, HW-emulsions, most synthetic hydraulic fluids and lubrication oils. Ship classifications available upon request.

6. Technical data:

operating temperature: - 10°C to +100°C
operating medium: mineral oil, other media on request
max. operating pressure: 16 bar
test pressure: 23 bar
connection system: flange connection DIN EN1092-1, 16 bar
housing material: C-steel
sealing material: Nitrile (NBR) or Viton (FPM), other materials on request
installation position: vertical
mini-measuring connection: G ¼

Classified under the Pressure Equipment Directive 2014/68/EU for mineral oil (fluid group 2), Article 4, Para. 3.
Classified under ATEX Directive 2014/34/EU according to specific application (see questionnaire sheet-no. 34279-4).

7. Symbols:

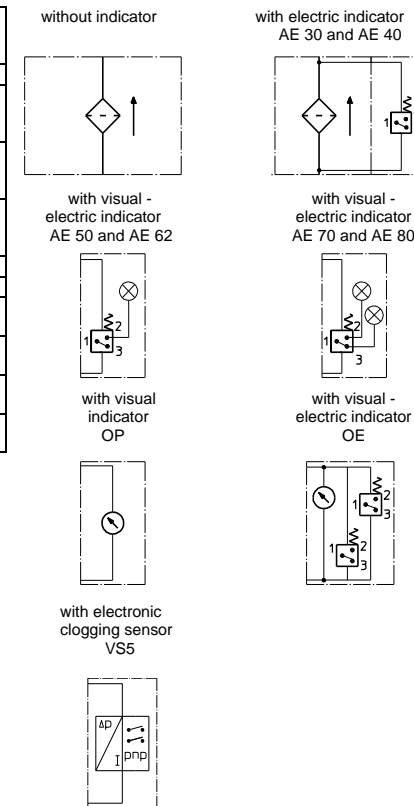

8. Pressure drop flow curves:

Precise flow rates see 'Interactive Product Specifier', respectively Δp-curves; depending on filter fineness and viscosity.

9. Test methods:

Filter elements are tested according to the following ISO standards:

ISO 2941 Verification of collapse/burst resistance
ISO 2942 Verification of fabrication integrity
ISO 2943 Verification of material compatibility with fluids
ISO 3723 Method for end load test
ISO 3724 Verification of flow fatigue characteristics
ISO 3968 Evaluation of pressure drop versus flow characteristics
ISO 16889 Multi-pass method for evaluating filtration performance