

# Series EDA 1006

## NPS 3" CLASS 150-300 PSI

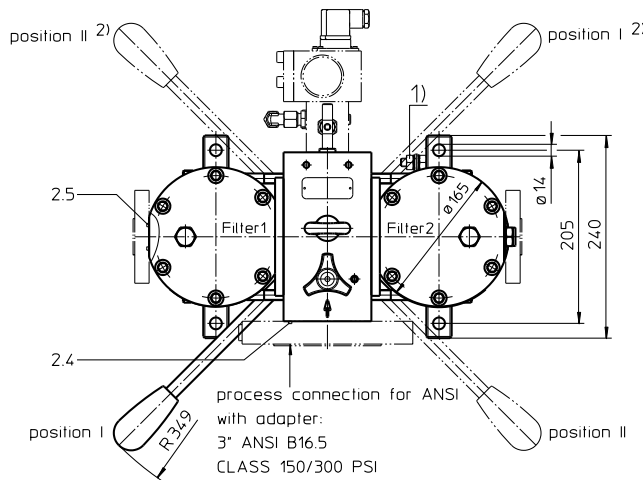
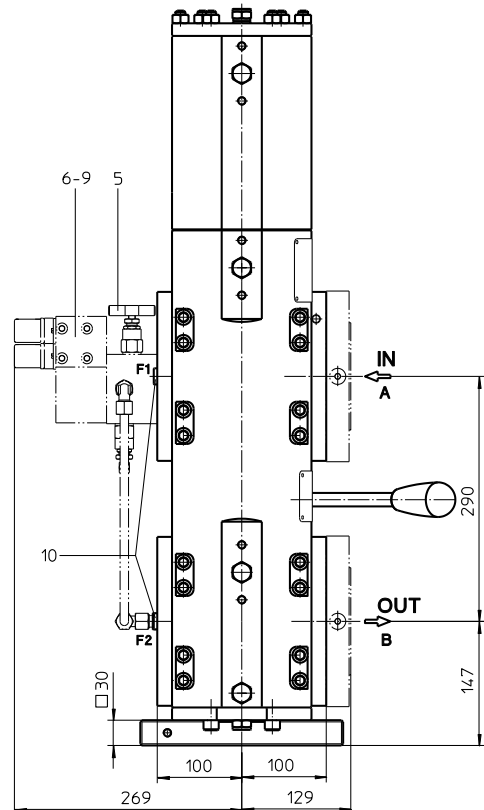
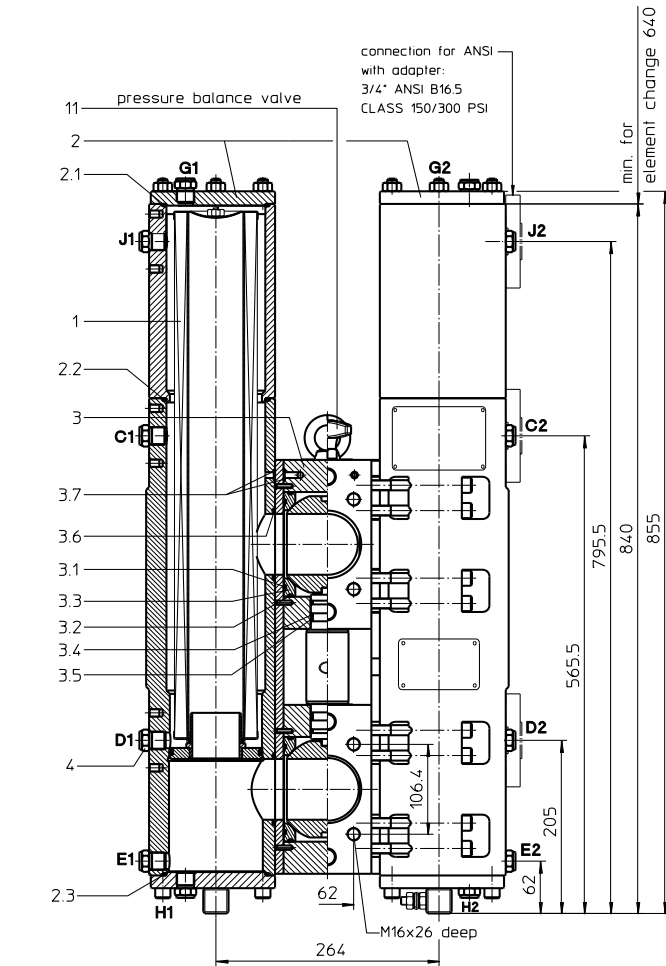

Position I: Filter 1 in operation  
Position II: Filter 2 in operation

- 1) Connection for the potential equalization, only for application in the explosive area.

Switch lever standard in the front.

- 2) On request:  
The switch lever can be moved to backside of the changeover valve, opposite to the inlet and outlet.  
Please specify this configuration on the order.

**Assignment of connections and functions:**

- A: process inlet SAE 3" 3000PSI
- B: process outlet SAE 3" 3000 PSI
- C1/C2: air bleeding NPT 1/2"
- D1/D2: drain, dirt side NPT 1/2"
- E1/E2: drain, clean side NPT 1/2"
- F1: measuring connection G 1/4" dirt side
- F2: measuring connection G 1/4" clean side
- G1/G2: air bleeding NPT 1/2"
- H1/H2: drain bottom NPT 1/2"
- J1/J2: air bleeding NPT 1/2"

# Pressure Filter, change over Series EDA 1006 NPS 3" CLASS 150-300 PSI

## Description:

Stainless steel-pressure filter series EDA 1006 have a working pressure up to 40 bar. Pressure peaks can be absorbed with a sufficient safety margin.

A changeover ball valve between the two filter housings makes it possible to switch from the dirty filter side to the clean filter side without interrupting operation.

The filter element consists of star-shaped, pleated filter material which is supported on the inside by a perforated core tube and is bonded to the end caps with a high-quality adhesive. The flow direction is from outside to inside.

For cleaning the stainless steel mesh element (see special leaflets 21070-4 and 39448-4) or changing the filter element, remove the cover and take out the element. The mesh elements are not guaranteed to maintain 100% performance after cleaning.

For filtration finer than 40 µm use disposable elements made of microglass. Filter elements as fine as 5 µm(c) are available; finer filter elements are available upon request.

Eaton filter elements are known for a high intrinsic stability and an excellent filtration capability, a high dirt-retaining capacity and a long service life.

Eaton filter elements are suitable for all petroleum based fluids, HW-emulsions, most synthetic hydraulic fluids and lubrication oils.

Ship classifications available upon request.

## Type index:

**Complete filter:** (ordering example)

**EDA. 1006. 10VG. 30. E. P. VA. FS. A. - . VA.**

1	2	3	4	5	6	7	8	9	10	11
---	---	---	---	---	---	---	---	---	----	----

**IS21. AB. OE**

12	13	14
----	----	----

**1 series:**

EDA = stainless steel-pressure filter change over, acc. to ASME-Code

**2 nominal size:** 1006

**3 filter material:**

80G, 40G, 25G, 10G stainless steel wire mesh  
25VG, 16VG, 10VG, 6VG, 3VG microglass  
25API, 10API microglass according to API

**4 filter element collapse rating:**

30 = Δp 30 bar

**5 filter element design:**

E = single-end open  
S = with by-pass valve Δp 2,0 bar  
S1 = with by-pass valve Δp 3,5 bar

**6 sealing material:**

P = Nitrile (NBR) V = Viton (FPM)

**7 filter element specification:**

- = standard VA = stainless steel

**8 process connection:**

FS = flange SAE 3000 PSI  
FA1 = flange ANSI CLASS 300 PSI <sup>1)</sup>  
FA2 = flange ANSI CLASS 300 PSI <sup>2)</sup>  
FA11 = flange ANSI CLASS 150 PSI <sup>1)</sup>  
FA12 = flange ANSI CLASS 150 PSI <sup>2)</sup>

**9 process connection size:**

A = 3"

**10 air bleeding/drain dirt side:**

- = standard (NPT ½")  
FA1 = flange ANSI ¾" CLASS 300 PSI <sup>1)</sup>  
FA2 = flange ANSI ¾" CLASS 300 PSI <sup>2)</sup>  
FA11 = flange ANSI ¾" CLASS 150 PSI <sup>1)</sup>  
FA12 = flange ANSI ¾" CLASS 150 PSI <sup>2)</sup>

**11 filter housing specification:**

VA = stainless steel, see sheet-no. 69578

**12 specification pressure vessel:**

IS21 = ASME VIII Div.1 with U-stamp, see sheet-no. 43415  
IS23 = ASME VIII Div.1 without U-stamp, see sheet-no. 55218

**13 shut-off:**

- = without  
AB = with shut-off block

**14 clogging indicator or clogging sensor:**

- = without  
AE = visual-electric, see sheet-no. 1609  
OP = visual, see sheet-no. 1628  
OE = visual-electric, see sheet-no. 1628  
VS5 = electronic, see sheet-no. 1641

To add an indicator/sensor to your filter, use the corresponding indicator data sheet to find the indicator details and add them to the filter assembly model code.

<sup>1)</sup> sealing surface Rz = 160 µm (not finer than 40 µm)

<sup>2)</sup> sealing surface Rz = 16 µm

**Filter element:** (ordering example)

**01NL. 1000.10VG. 30. E. P. VA**

1	2	3	4	5	6	7
---	---	---	---	---	---	---

**1 series:**

01NL = standard filter element according to DIN 24550, T3

**2 nominal size:** 1000

**3 - 7** see type index-complete filter

## Accessories:

- SAE-counter flanges, see sheet-no. 1652

- drain- and bleeder connection, see sheet-no. 1659

## Technical data:

operating temperature:	- 10°C to +100°C
operating medium:	mineral oil, other media on request
max. operating pressure (pressure vessel):	40 bar
test pressure acc. to ASME VIII Div. 1:	1,3 x operating pressure = 52 bar
test pressure acc. to API 614, Chapter 1:	1,5 x operating pressure = 60 bar
process connection system:	SAE-flange 3000 PSI or ANSI-flange B16.5 CLASS 150/300 PSI
housing material:	stainless steel, see sheet-no. 69578
sealing material:	Nitrile (NBR) or Viton (FPM), other materials on request
installation position:	vertical
bleeder connection:	NPT ½" or ANSI ¾" CLASS 150/300 PSI
drain connection dirt side:	NPT ½" or ANSI ¾" CLASS 150/300 PSI
drain connection clean side:	NPT ½"
volume tank:	2x 8,6 l
operating pressure adapter flanges:	according to B16.5 CLASS 150 PSI (FA11/FA12 max. 16 bar) according to B16.5 CLASS 300 PSI (FA1/FA2 max. 40 bar)

Classified under the Pressure Equipment Directive 2014/68/EU for mineral oil (fluid group 2), Article 4, Para. 3. Classified under ATEX Directive 2014/34/EU according to specific application (see questionnaire sheet-no. 34279-4)

## Pressure drop flow curves:

### Filter calculation/sizing

The pressure drop of the assembly at a given flow rate Q is the sum of the housing  $\Delta p$  and the element  $\Delta p$  and is calculated as follows:

$$\Delta p_{assembly} = \Delta p_{housing} + \Delta p_{element}$$

$$\Delta p_{housing} = (\text{see } \Delta p = f(Q) \text{ - characteristics})$$

$$\Delta p_{Element} (mbar) = Q \left( \frac{l}{min} \right) \times \frac{MSK (mbar)}{10 \left( \frac{l}{min} \right)} \times v \left( \frac{mm^2}{s} \right) \times \frac{\rho (kg)}{0,876 (dm^3)}$$

For ease of calculation our Filter Selection tool is available online at [www.eaton.com/hydraulic-filter-evaluation](http://www.eaton.com/hydraulic-filter-evaluation)

### Material gradient coefficients (MSK) for filter elements

The material gradient coefficients in mbar/(l/min) apply to mineral oil (HLP) with a density of 0,876 kg/dm<sup>3</sup> and a kinematic viscosity of 30 mm<sup>2</sup>/s (139 SUS). The pressure drop changes proportionally to the change in kinematic viscosity and density.

EDA	VG					G				API	
	3VG	6VG	10VG	16VG	25VG	10G	25G	40G	80G	10 API	25 API
1006	0,276	0,192	0,123	0,107	0,073	0,0134	0,0099	0,0093	0,0064	0,063	0,029

### $\Delta p=f(Q)$ – characteristic according ISO 3968

The pressure drop characteristics apply to mineral oil (HLP) with a density of 0,876 kg/dm<sup>3</sup>. The pressure drop changes proportionally to the density.

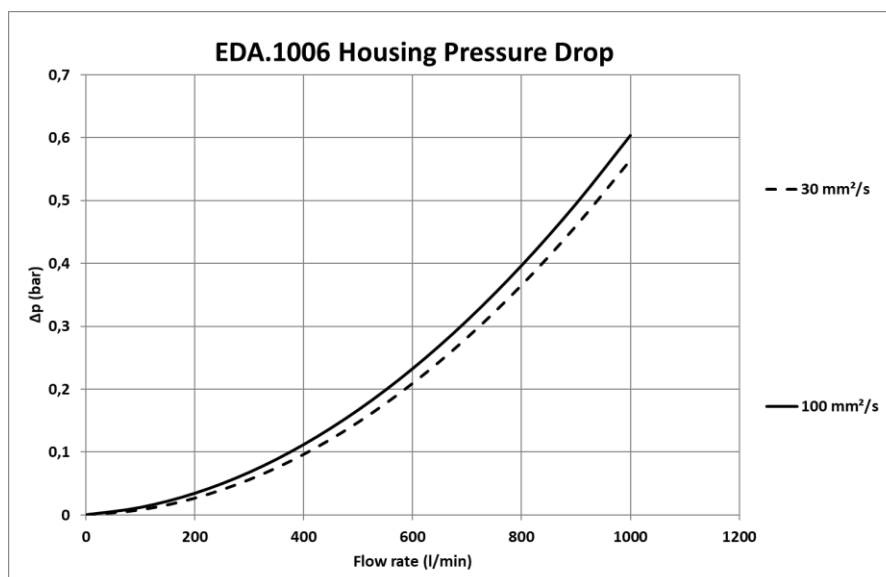

## Symbols:

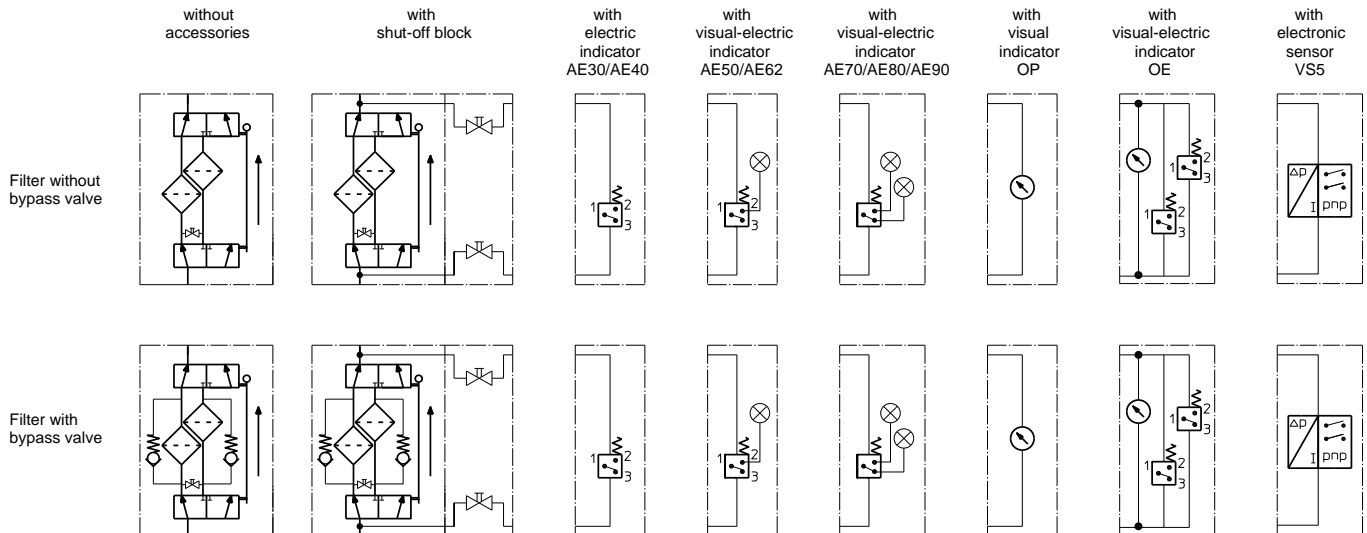

## Spare parts:

item	qty.	designation	dimension	article-no.
1	2	filter element	01.NL1000...	
2		<b>gaskets for filter housing:</b>		
2.1	2	O-ring	120 x 3,5	305146 (NBR) 305202 (FPM)
2.2	2	O-ring	120 x 3,5	305146 (NBR) 305202 (FPM)
2.3	2	O-ring	120 x 3,5	305146 (NBR) 305202 (FPM)
2.4	2	O-ring	85 x 4	305685 (NBR) 310285 (FPM)
2.5	6	O-ring	24,99 x 3,53	304381 (NBR) 305784 (FPM)
3	1	<b>gasket kit of switching over consisting of:</b>	DN80 (3")	354246 (NBR) 354249 (FPM)
3.1	4	O-ring	98 x 4	
3.2	4	O-ring	110,72 x 3,53	
3.3	4	gasket ring	DN80	
3.4	4	O-ring	34 x 3,5	
3.5	2	support ring	40 x 34,4 x 5	
3.6	4	O-ring	74 x 3,5	
3.7	4	O-ring	7 x 2	
4	12	screw plug	NPT 1/2"	307766
5	1	shut-off block		
6	1	clogging indicator, visual-electric	OE	see sheet-no. 1628
7	1	clogging indicator, visual	OP	see sheet-no. 1628
8	1	clogging indicator, visual-electric	AE	see sheet-no. 1609
9	1	clogging sensor, electronic	VS5	see sheet-no. 1641
10	2	screw plug	G 1/4	306968
11	1	pressure balance valve	DN10	310316

## Test methods:

Filter elements are tested according to the following ISO standards:

ISO 2941	Verification of collapse/burst resistance
ISO 2942	Verification of fabrication integrity
ISO 2943	Verification of material compatibility with fluids
ISO 3723	Method for end load test
ISO 3724	Verification of flow fatigue characteristics
ISO 3968	Evaluation of pressure drop versus flow characteristics
ISO 16889	Multi-pass method for evaluating filtration performance

**North America**  
44 Apple Street  
Tinton Falls, NJ 07724  
Toll Free: 800 656-3344  
(North America only)  
Tel: +1 732 212-4700

**Greater China**  
No. 7, Lane 280,  
Linhong Road  
Changning District, 200335  
Shanghai, P.R. China  
Tel: +86 21 5200-0099

**Europe/Africa/Middle East**  
Auf der Heide 2  
53947 Nettersheim, Germany  
Tel: +49 2486 809-0

**Asia-Pacific**  
100G Pasir Panjang Road  
#07-08 Interlocal Centre  
Singapore 118523  
Tel: +65 6825-1668

Friedensstraße 41  
68804 Altludersheim, Germany  
Tel: +49 6205 2094-0

An den Nahewiesen 24  
55450 Langenlonsheim, Germany  
Tel: +49 6704 204-0

**EATON**  
Powering Business Worldwide

**For more information, please  
email us at [filtration@eaton.com](mailto:filtration@eaton.com)  
or visit [www.eaton.com/filtration](http://www.eaton.com/filtration)**

© 2021 Eaton. All rights reserved. All trademarks and registered trademarks are the property of their respective owners. All information and recommendations appearing in this brochure concerning the use of products described herein are based on tests believed to be reliable. However, it is the user's responsibility to determine the suitability for his own use of such products. Since the actual use by others is beyond our control, no guarantee, expressed or implied, is made by Eaton as to the effects of such use or the results to be obtained. Eaton assumes no liability arising out of the use by others of such products. Nor is the information herein to be construed as absolutely complete, since additional information may be necessary or desirable when particular or exceptional conditions or circumstances exist or because of applicable laws or government regulations.