

Series DWFA 1505 CLASS 150 PSI

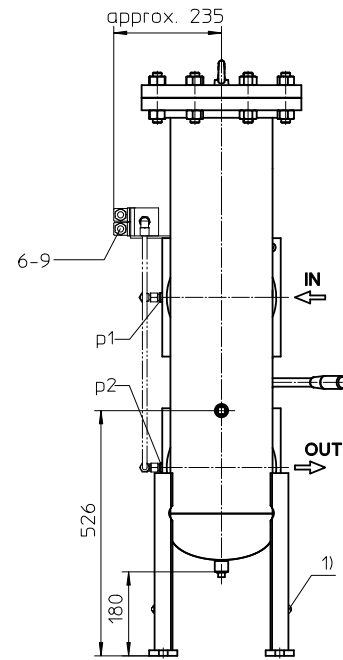

p1/p2 = mini-measuring connection G1/4

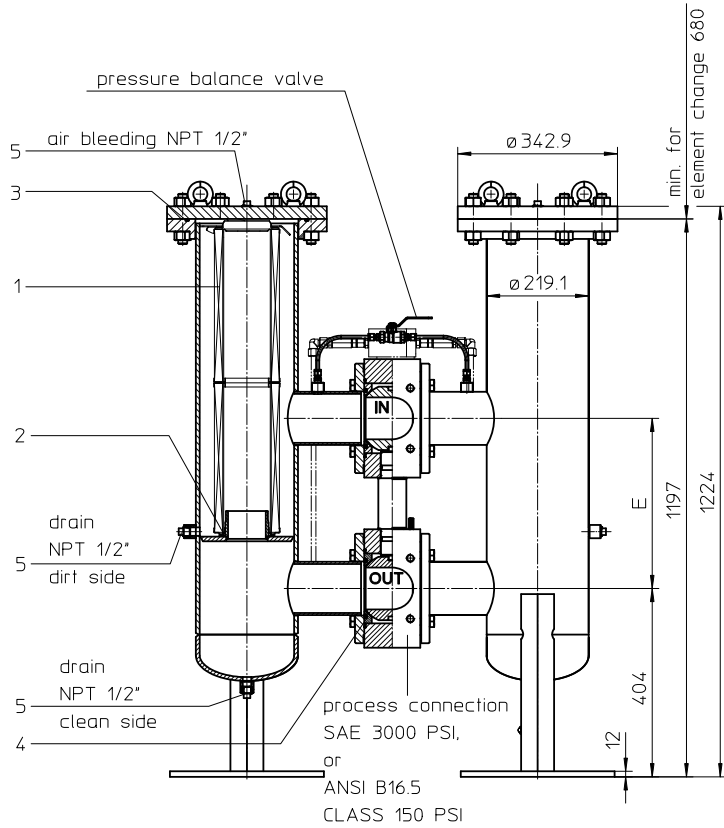
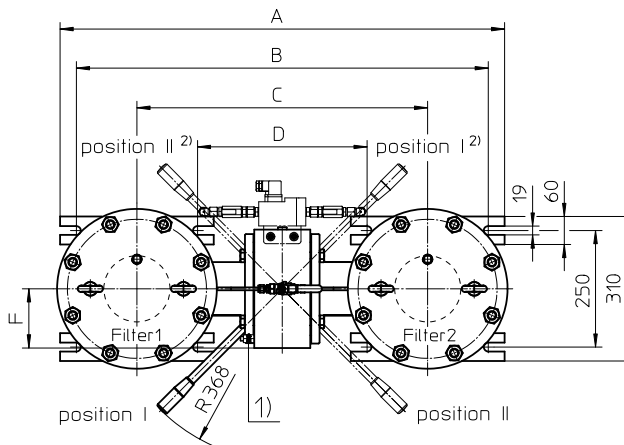

- 1) Connection for the potential equalization, only for application in the explosive area.

Switch lever standard in the front.

- 2) On request: The switch lever can be moved to backside of the changeover valve, opposite to the inlet and outlet.

Please specify this configuration on the order.

Position I: Filter 1 in operation
Position II: Filter 2 in operation

Dimensions:

process connection	A	B	C	D	E	SAE	F	ANSI	weight	volume tank
4" (DN100)	954	884	624	364	365	127		255	325 kg	2x 31 l
5" (DN125)	988	918	658	398	395	135		276	307 kg	2x 31 l

Dimensions: mm

Designs and performance values are subject to change.



Powering Business Worldwide

Pressure Filter, change over Series DWFA 1505 CLASS 150 PSI

Description:

Pressure filter change over series DWFA 1505 have a working pressure up to 16 bar. Pressure peaks can be absorbed with a sufficient safety margin.

A changeover ball valve between the two filter housings makes it possible to switch from the dirty filter side to the clean filter side without interrupting operation. The filters can be installed as a suction filter, pressure filter or return line filter.

The filter element consists of star-shaped, pleated filter material, which is supported on the inside by a perforated core tube and is bonded to the end caps with a high-quality adhesive. The flow direction is from outside to inside.

For cleaning the stainless steel mesh element (see special leaflets 21070-4 and 39448-4) or changing the filter element, remove the cover and take out the element. The mesh elements are not guaranteed to maintain 100% performance after cleaning.

For filtration finer than 25 µm, use the disposable elements made of microglass. Filter elements as fine as 3 µm are available; finer filter elements are available upon request.

Eaton filter elements are known for high intrinsic stability and an excellent filtration capability, a high dirt-retaining capacity and a long service life.

Eaton filter are suitable for all petroleum based fluids, HW-emulsions, most synthetic hydraulic fluids and lubrication oils.

Ship classifications available upon request.

Type index:

Complete filter: (ordering example)

DWFA. 1505. 10VG. 10. E. P. -. FS. B. -. IS21.

1	2	3	4	5	6	7	8	9	10	11
---	---	---	---	---	---	---	---	---	----	----

KH. OE

12	13
----	----

1 series:

DWFA = double welded filter, according to ASME-code

2 nominal size: 1505

3 filter material:

80G, 40G, 25G, 10G stainless steel wire mesh
25VG, 16VG, 10VG, 6VG, 3VG microglass
25API, 10API microglass according to API

4 filter element collapse rating:

10 = Δp 10 bar

5 filter element design:

E = without by-pass
S = with by-pass valve Δp 2,0 bar

6 sealing material:

P = Nitrile (NBR)
V = Viton (FPM)

7 filter element specification:

- = standard
VA = stainless steel
IS06 = for HFC application, see sheet-no. 31601

8 process connection:

FS = SAE-flange 3000 PSI
FA11 = flange ANSI CLASS 150 PSI,
sealing surface Rz = 160 µm (not finer than 40 µm)
FA12 = flange ANSI CLASS 150 PSI,
sealing surface Rz = 16 µm

9 process connection size:

B = 4" (DN100) standard
C = 5" (DN125)

10 filter housing specification:

- = standard
IS12 = internal parts of change over armature stainless steel,
see sheet-no. 41028

11 specification pressure vessel:

IS21 = ASME VIII Div.1 with U-stamp, see sheet-no. 43415

12 shut-off :

- = without
KH = with shut-off ball valve

13 clogging indicator or clogging sensor:

- = without
AE = visual-electric, see sheet-no. 1609
OP = visual, see sheet-no. 1614
OE = visual-electric, see sheet-no. 1614
VS5 = sensor, see sheet-no. 1641

To add an indicator/sensor to your filter, use the corresponding indicator data sheet to find the indicator details and add them to the filter assembly model code.

Filter element: (ordering example)

01E. 1501. 10VG. 10. E. P. -

1	2	3	4	5	6	7
---	---	---	---	---	---	---

1 series:

01E = filter element according to company standard

2 nominal size: 1501

3 - 7 see type index-complete filter

Accessories:

- drain- and bleeder connection, see sheet-no. 1651
- lifting mechanism, see sheet-no. 1662

Technical data:

operating temperature:	-10 °C to +100 °C
operating medium:	mineral oil, other media on request
max. operating pressure:	16 bar
test pressure acc. to ASME VIII Div. 1:	1,3 x operating pressure = 21 bar
test pressure acc. to API 614, Chapter 1:	1,5 x operating pressure = 24 bar
standard process connection:	SAE-flange 3000 PSI
housing material:	carbon steel (ASTM)
housing material changeover 4":	carbon steel
housing material changeover 5":	EN-GJS-400-18-LT
sealing material:	Nitrile (NBR) or Viton (FPM), other materials on request
installation position:	vertical
drain- and bleeder connections:	NPT ½"
measure connections:	G ¼
operating pressure adapter flanges:	according to B16.5 CLASS 150 PSI (max. 16 bar)

Classified under the Pressure Equipment Directive 2014/68/EU for mineral oil (fluid group 2), Article 4, Para. 3.
 Classified under ATEX Directive 2014/34/EU according to specific application (see questionnaire sheet-no. 34279-4).

Pressure drop flow curves:

Filter calculation/sizing

The pressure drop of the assembly at a given flow rate Q is the sum of the housing Δp and the element Δp and is calculated as follows:

$$\Delta p_{assembly} = \Delta p_{housing} + \Delta p_{element}$$

$$\Delta p_{housing} = (\text{see } \Delta p = f(Q) - \text{characteristics})$$

$$\Delta p_{Element} (mbar) = Q \left(\frac{l}{min} \right) \times \frac{MSK}{10} \left(\frac{mbar}{l/min} \right) \times v \left(\frac{mm^2}{s} \right) \times \frac{p}{0,876} \left(\frac{kg}{dm^3} \right)$$

For ease of calculation, our Filter Selection tool is available online at: www.eatonpowersource.com/calculators/filtration/

Material gradient coefficients (MSK) for filter elements

The material gradient coefficients in mbar/(l/min) apply to mineral oil (HLP) with a density of 0.876 kg/dm³ and a kinematic viscosity of 30 mm²/s (139 SUS). The pressure drop changes proportionally to the change in kinematic viscosity and density.

DWFA	VG					G				API	
	3VG	6VG	10VG	16VG	25VG	10G	25G	40G	80G	10 API	25 API
1505	0,160	0,111	0,071	0,062	0,042	0,0058	0,0043	0,0040	0,0027	0,039	0,018

$\Delta p = f(Q)$ – characteristics according to ISO 3968

The pressure drop characteristics apply to mineral oil (HLP) with a density of 0,876 kg/dm³. The pressure drop changes proportionally to the density. The flow curve for DN125 available on request.

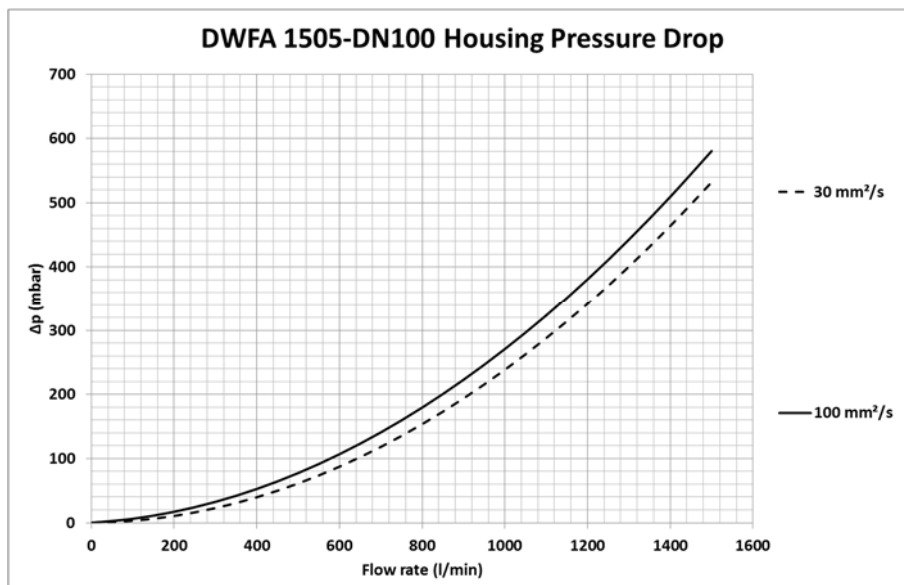

Symbols:

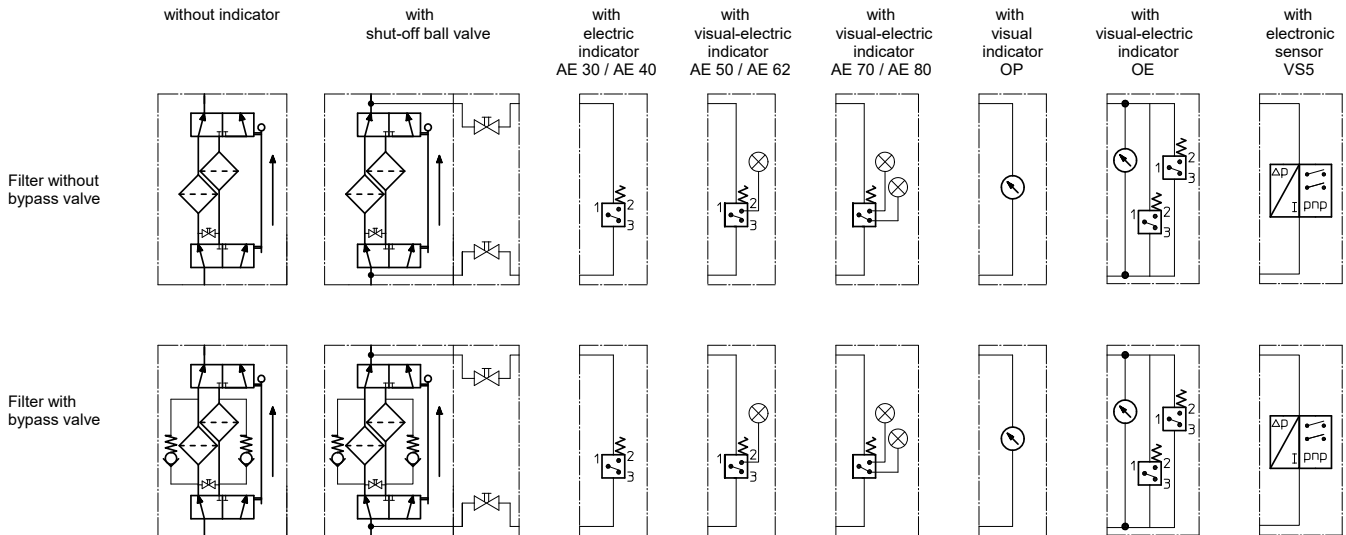

Spare parts:

item	qty.	designation	dimension	Article-no.
1	2	filter element	01E.1501...	
2	2	O-ring	93 x 5	307588 (NBR) 307589 (FPM)
3	2	O-ring	9.975" ID x 0.210 CS	ST521Z6B (BUNA-N)
4	4	gasket kit of change over UKK	4" (DN100)	
	4	gasket kit of change over UKK	5" (DN125)	
5	6	screw plug	NPT 1/2"	ST260Z35
6	1	clogging indicator, visual-electric	AE	see sheet-no.1609
7	1	clogging indicator, visual	OP	see sheet-no 1614
8	1	clogging indicator, visual-electric	OE	see sheet-no 1614
9	1	clogging sensor, electronic	VS5	see sheet-no 1641

Test methods:

Filter elements are tested according to the following ISO standards:

ISO 2941	Verification of collapse/burst resistance
ISO 2942	Verification of fabrication integrity
ISO 2943	Verification of material compatibility with fluids
ISO 3723	Method for end load test
ISO 3724	Verification of flow fatigue characteristics
ISO 3968	Evaluation of pressure drop versus flow characteristics
ISO 16889	Multi-pass method for evaluating filtration performance

North America
44 Apple Street
Tinton Falls, NJ 07724
Toll Free: 800 656-3344
(North America only)
Tel: +1 732 212-4700

China
No. 3, Lane 280,
Linhong Road
Changning District, 200335
Shanghai, P.R. China
Tel: +86 21 5200-0099

Europe/Africa/Middle East
Auf der Heide 2
53947 Nettersheim, Germany
Tel: +49 2486 809-0

Friedensstraße 41
68804 Altlußheim, Germany
Tel: +49 6205 2094-0

An den Nahewiesen 24
55450 Langenlonsheim, Germany
Tel: +49 6704 204-0

Singapore
100G Pasir Panjang Road #07-08
Singapore 118523
Tel: +65 6825-1668

Brazil
Av. Ermano Marchetti, 1435 -
Água Branca, São Paulo - SP,
05038-001, Brazil
Tel: +55 11 3616-8461

For more information, please
email us at filtration@eaton.com
or visit www.eaton.com/filtration

© 2019 Eaton. All rights reserved. All trademarks and registered trademarks are the property of their respective owners. All information and recommendations appearing in this brochure concerning the use of products described herein are based on tests believed to be reliable. However, it is the user's responsibility to determine the suitability for his own use of such products. Since the actual use by others is beyond our control, no guarantee, expressed or implied, is made by Eaton as to the effects of such use or the results to be obtained. Eaton assumes no liability arising out of the use by others of such products. Nor is the information herein to be construed as absolutely complete, since additional information may be necessary or desirable when particular or exceptional conditions or circumstances exist or because of applicable laws or government regulations.