

# Series DWF 3005 PN 16

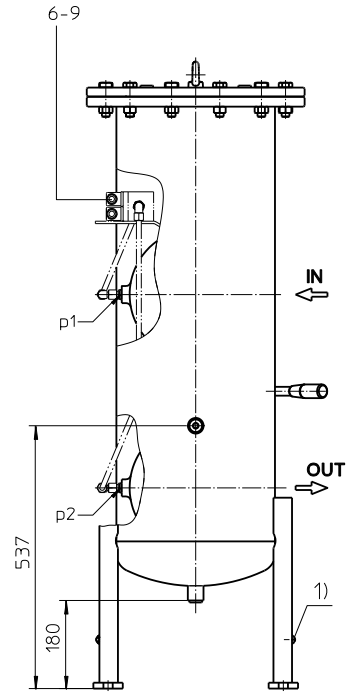

p1/p2 = mini-measuring connection G1/4

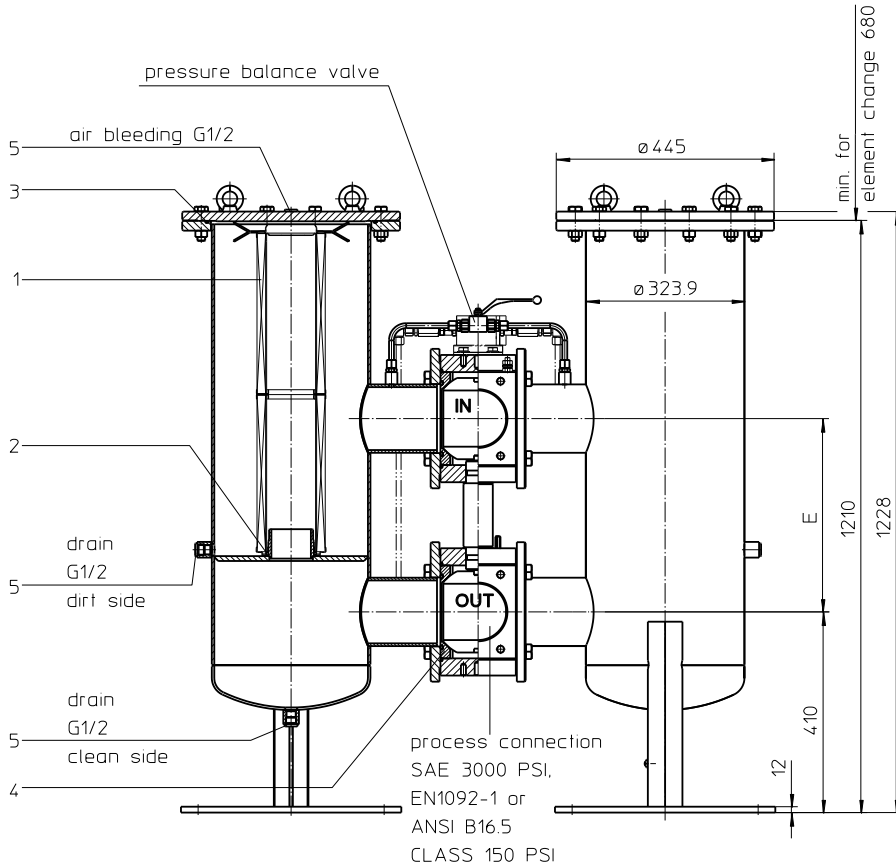
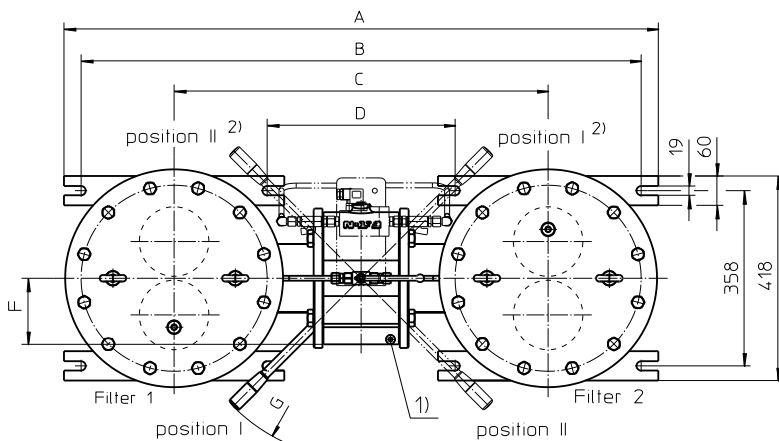

- 1) Connection for the potential equalization, only for application in the explosive area.

**Switch lever standard in the front.**

- 2) On request: The switch lever can be moved to backside of the changeover valve, opposite to the inlet and outlet. Please specify this configuration on the order.

Position I: Filter 1 in operation  
Position II: Filter 2 in operation

### Dimensions:

process connection	A	B	C	D	E	SAE	F	DIN EN	ANSI	G	weight kg	volume tank
4" (DN100)	1170	1100	720	340	365	127	231	255	255	370	240	2x 76 l
5" (DN125)	1214	1144	764	384	395	135	242	276	276	370	296	2x 76 l
6" (DN150)	1236	1166	786	406	440	-	207	207	207	430	382	2x 76 l



Powering Business Worldwide

Dimensions: mm  
Designs and performance values are subject to change.

# Pressure filter, change over Series DWF 3005 PN 16

## Description:

Pressure filter change over series DWF 3005 have a working pressure up to 16 bar. Pressure peaks can be absorbed with a sufficient safety margin.

A changeover ball valve between the two filter housings makes it possible to switch from the dirty filter side to the clean filter side without interrupting operation. The filters can be installed as a suction filter, pressure filter or return line filter.

The filter element consists of star-shaped, pleated filter material, which is supported on the inside by a perforated core tube and is bonded to the end caps with a high-quality adhesive. The flow direction is from outside to inside.

For cleaning the stainless steel mesh element (see special leaflets 21070-4 and 39448-4) or changing the filter element, remove the cover and take out the element. The mesh elements are not guaranteed to maintain 100% performance after cleaning.

For filtration finer than 25 µm, use the disposable elements made of microglass. Filter elements as fine as 3 µm are available; finer filter elements are available upon request.

Eaton filter elements are known for high intrinsic stability and an excellent filtration capability, a high dirt-retaining capacity and a long service life.

Eaton filters are suitable for all petroleum based fluids, HW-emulsions, most synthetic hydraulic fluids and lubrication oils.

Ship classifications available upon request.

## Type index:

**Complete filter:** (ordering example)

<b>DWF.</b>	<b>3005.</b>	<b>10VG.</b>	<b>10.</b>	<b>E.</b>	<b>P.</b>	<b>-.</b>	<b>FS.</b>	<b>C.</b>	<b>-.</b>	<b>-.</b>
1	2	3	4	5	6	7	8	9	10	11

### KH. OE

12	13
----	----

- |    |                                                                                                                                                                                                                                                                                                                               |
|----|-------------------------------------------------------------------------------------------------------------------------------------------------------------------------------------------------------------------------------------------------------------------------------------------------------------------------------|
| 1  | <b>series:</b><br>DWF = double welded filter                                                                                                                                                                                                                                                                                  |
| 2  | <b>nominal size:</b> 3005                                                                                                                                                                                                                                                                                                     |
| 3  | <b>filter material:</b><br>80G, 40G, 25G, 10G stainless steel wire mesh<br>25VG, 16VG, 10VG, 6VG, 3VG microglass<br>25API, 10API microglass according to API                                                                                                                                                                  |
| 4  | <b>filter element collapse rating:</b><br>10 = Δp 10 bar                                                                                                                                                                                                                                                                      |
| 5  | <b>filter element design:</b><br>E = without by-pass<br>S = with by-pass valve Δp 2,0 bar                                                                                                                                                                                                                                     |
| 6  | <b>sealing material:</b><br>P = Nitrile (NBR)<br>V = Viton (FPM)                                                                                                                                                                                                                                                              |
| 7  | <b>filter element specification:</b><br>- = standard<br>VA = stainless steel<br>IS06 = for HFC application, see sheet-no. 31601                                                                                                                                                                                               |
| 8  | <b>process connection:</b><br>FS = SAE-flange 3000 PSI (only with connection 4" and 5")<br>FD1 = flange EN1092-1, design B1<br>FD2 = flange EN1092-1, design B2<br>FA11 = flange ANSI CLASS 150 PSI,<br>sealing surface Rz = 160 µm (not finer than 40 µm)<br>FA12 = flange ANSI CLASS 150 PSI,<br>sealing surface Rz = 16 µm |
| 9  | <b>process connection size:</b><br>B = 4" (DN100)<br>C = 5" (DN125) standard<br>D = 6" (DN150)                                                                                                                                                                                                                                |
| 10 | <b>filter housing specification:</b><br>- = standard<br>IS12 = internal parts of change over armature stainless steel,<br>see sheet-no. 41028                                                                                                                                                                                 |
| 11 | <b>specification pressure vessel:</b><br>- = standard (PED 2014/68/EU)<br>IS20 = ASME VIII Div.1 with ASME equivalent material,<br>see sheet-no. 55217                                                                                                                                                                        |
| 12 | <b>shut-off :</b><br>- = without<br>KH = with shut-off ball valve                                                                                                                                                                                                                                                             |
| 13 | <b>clogging indicator or clogging sensor:</b><br>- = without<br>AE = visual-electric, see sheet-no. 1609<br>OP = visual, see sheet-no. 1614<br>OE = visual-electric, see sheet-no. 1614<br>VS5 = electronic, see sheet-no. 1641                                                                                               |

To add an indicator/sensor to your filter, use the corresponding indicator data sheet to find the indicator details and add them to the filter assembly model code.

**Filter element:** (ordering example)

<b>01E.</b>	<b>1501.</b>	<b>10VG.</b>	<b>10.</b>	<b>E.</b>	<b>P.</b>	<b>-</b>
1	2	3	4	5	6	7

- |   |                                                                      |
|---|----------------------------------------------------------------------|
| 1 | <b>series:</b><br>01E = filter element according to company standard |
| 2 | <b>nominal size:</b> 1501                                            |
| 3 | - 7 see type index-complete filter                                   |

## Accessories:

- drain- and bleeder connection, see sheet-no. 1651
- lifting mechanism, see sheet-no. 1662

## Technical data:

operating temperature:	-10 °C to +100 °C
operating medium:	mineral oil, other media on request
max. operating pressure:	16 bar
test pressure:	23 bar
standard process connection:	SAE-flange 3000 PSI
housing material:	carbon steel
housing material changeover 4":	carbon steel
housing material changeover 5"/6":	EN-GJS-400-18-LT
sealing material:	Nitrile (NBR) or Viton (FPM), other materials on request
installation position:	vertical
drain- and bleeder connections:	G ½
measure connections:	G ¼

Classified under the Pressure Equipment Directive 2014/68/EU for mineral oil (fluid group 2), Article 4, Para. 3.  
 Classified under ATEX Directive 2014/34/EU according to specific application (see questionnaire sheet-no. 34279).

## Pressure drop flow curves:

### Filter calculation/sizing

The pressure drop of the assembly at a given flow rate Q is the sum of the housing  $\Delta p$  and the element  $\Delta p$  and is calculated as follows:

$$\Delta p_{assembly} = \Delta p_{housing} + \Delta p_{element}$$

$$\Delta p_{housing} = (\text{see } \Delta p = f(Q) \text{ - characteristics})$$

$$\Delta p_{element} (mbar) = Q \left( \frac{l}{min} \right) \times \frac{MSK}{10} \left( \frac{mbar}{l/min} \right) \times v \left( \frac{mm^2}{s} \right) \times \frac{p}{0,876} \left( \frac{kg}{dm^3} \right)$$

For ease of calculation, our Filter Selection tool is available online at: [www.eaton.com/hydraulic-filter-evaluation](http://www.eaton.com/hydraulic-filter-evaluation)

### Material gradient coefficients (MSK) for filter elements

The material gradient coefficients in mbar/(l/min) apply to mineral oil (HLP) with a density of 0,876 kg/dm<sup>3</sup> and a kinematic viscosity of 30 mm<sup>2</sup>/s (139 SUS). The pressure drop changes proportionally to the change in kinematic viscosity and density.

DWF	VG					G				API	
	3VG	6VG	10VG	16VG	25VG	10G	25G	40G	80G	10 API	25 API
3005	0,080	0,056	0,036	0,031	0,021	0,0029	0,0021	0,0020	0,0014	0,019	0,009

### $\Delta p=f(Q)$ – characteristic according ISO 3968

The pressure drop characteristics apply to mineral oil (HLP) with a density of 0,876 kg/dm<sup>3</sup>. The pressure drop changes proportionally to the density. The flow curves for DN100 and DN150 available on request.

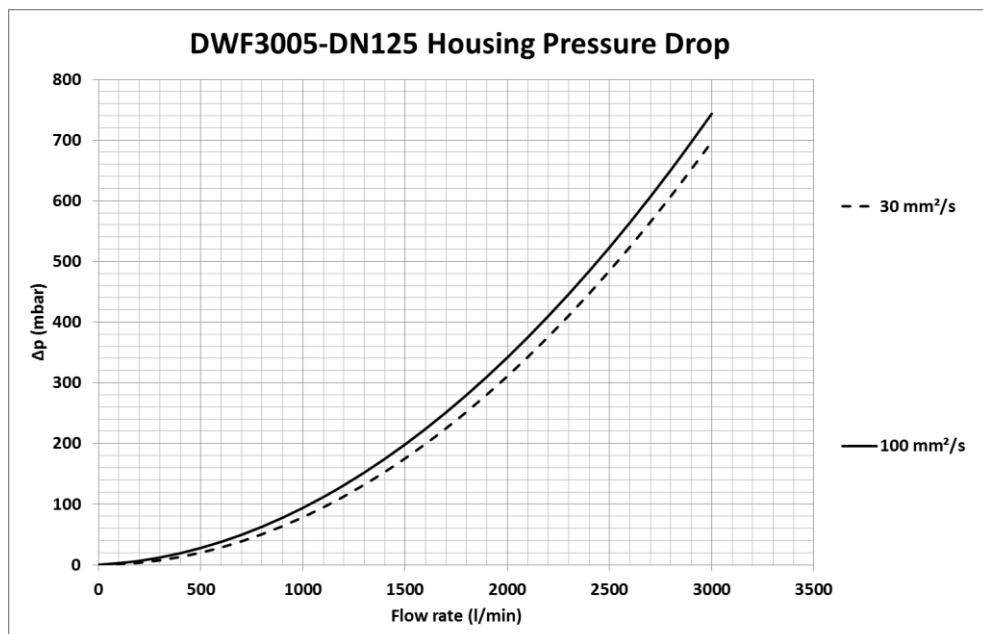

## Symbols:

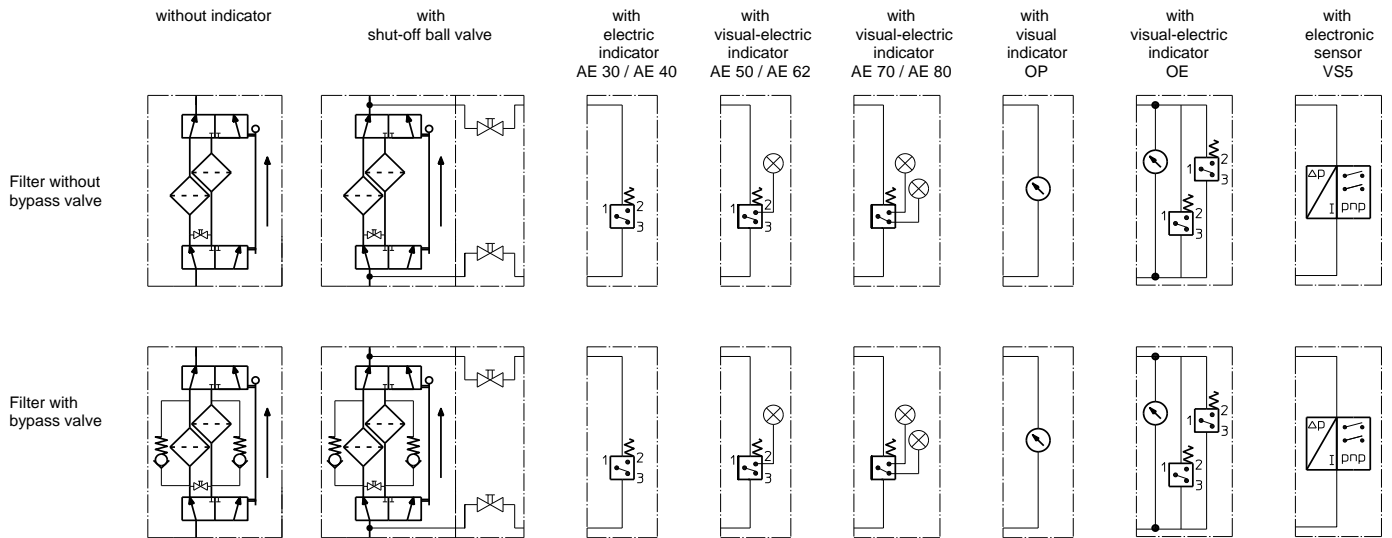

## Spare parts:

item	qty.	designation	dimension	article-no.
1	4	filter element	01E.1501...	
2	4	O-ring	93 x 5	307588 (NBR)   307589 (FPM)
3	2	O-ring	339 x 5	352792 (NBR)   352793 (FPM)
4	4	gasket kit of changeover UKK	4" (DN100)	
	4	gasket kit of changeover UKK	5" (DN125)	
	4	gasket kit of changeover UKK	6" (DN150)	
5	6	screw plug	G 1/2	304678
6	1	clogging indicator, visual-electric	AE	see sheet-no. 1609
7	1	clogging indicator, visual	OP	see sheet-no. 1614
8	1	clogging indicator, visual-electric	OE	see sheet-no. 1614
9	1	clogging sensor, electronic	VS5	see sheet-no. 1641

## Test methods:

Filter elements are tested according to the following ISO standards:

ISO 2941	Verification of collapse/burst resistance
ISO 2942	Verification of fabrication integrity
ISO 2943	Verification of material compatibility with fluids
ISO 3723	Method for end load test
ISO 3724	Verification of flow fatigue characteristics
ISO 3968	Evaluation of pressure drop versus flow characteristics
ISO 16889	Multi-pass method for evaluating filtration performance

**North America**  
44 Apple Street  
Tinton Falls, NJ 07724  
Toll Free: 800 656-3344  
(North America only)  
Tel: +1 732 212-4700

**Greater China**  
No. 7, Lane 280,  
Linhong Road  
Changning District, 200335  
Shanghai, P.R. China  
Tel: +86 21 5200-0099

**Europe/Africa/Middle East**  
Auf der Heide 2  
53947 Nettersheim, Germany  
Tel: +49 2486 809-0

**Asia-Pacific**  
100G Pasir Panjang Road  
#07-08 Interlocal Centre  
Singapore 118523  
Tel: +65 6825-1668

Friedensstraße 41  
68804 Altlufheim, Germany  
Tel: +49 6205 2094-0

An den Nahewiesen 24  
55450 Langenlonsheim, Germany  
Tel: +49 6704 204-0

**EATON**  
Powering Business Worldwide

**For more information, please  
email us at [filtration@eaton.com](mailto:filtration@eaton.com)  
or visit [www.eaton.com/filtration](http://www.eaton.com/filtration)**

© 2021 Eaton. All rights reserved. All trademarks and registered trademarks are the property of their respective owners. All information and recommendations appearing in this brochure concerning the use of products described herein are based on tests believed to be reliable. However, it is the user's responsibility to determine the suitability for his own use of such products. Since the actual use by others is beyond our control, no guarantee, expressed or implied, is made by Eaton as to the effects of such use or the results to be obtained. Eaton assumes no liability arising out of the use by others of such products. Nor is the information herein to be construed as absolutely complete, since additional information may be necessary or desirable when particular or exceptional conditions or circumstances exist or because of applicable laws or government regulations.