

Series DU 40

914 PSI

- 1) Connection for the potential equalization, only for application in the explosive area.

Connections III and IV to be used for pressure relief and air bleeding respective filter side.

Position I: left filter side in operation
 Position II: right filter side in operation

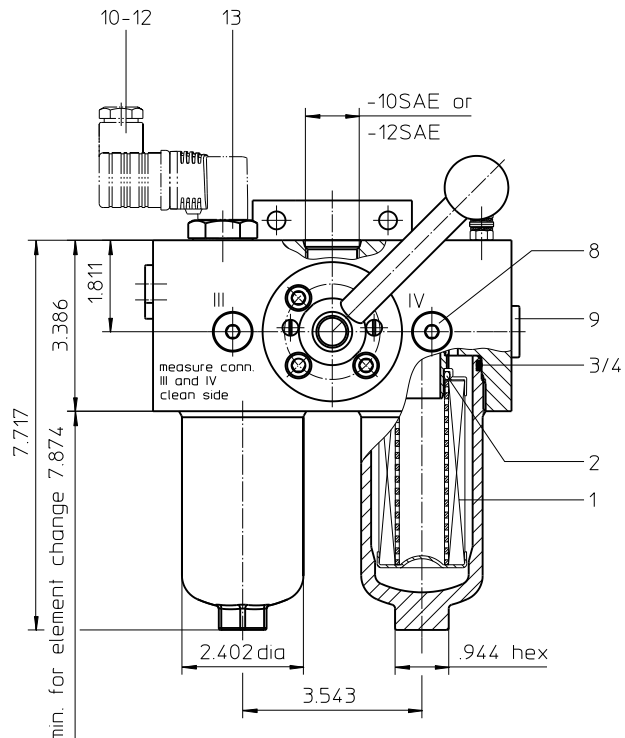
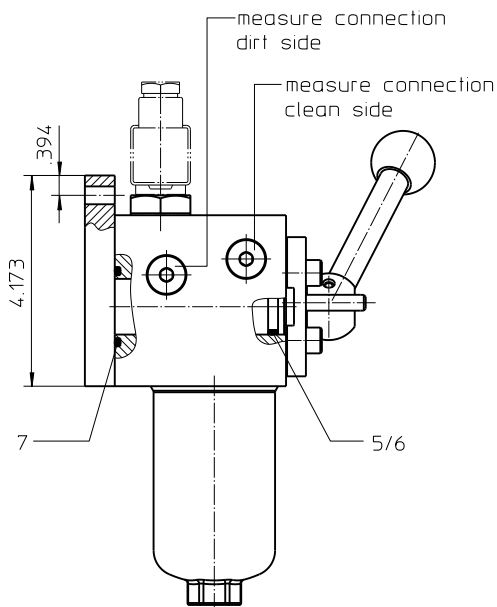
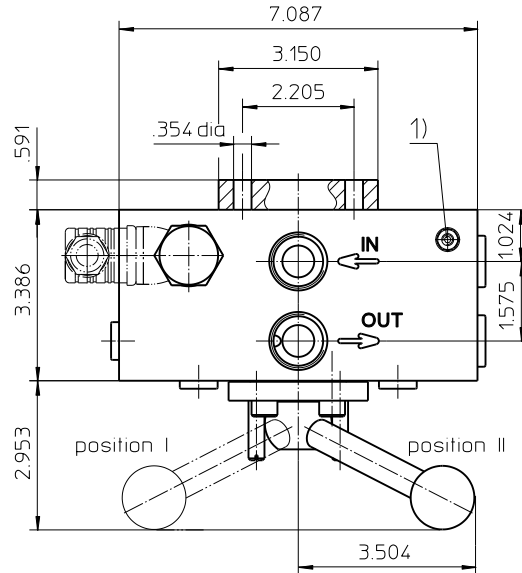

Weight: approx. 26 lbs.

Dimensions: mm

Designs and performance values are subject to change.



Powering Business Worldwide

Pressure Filter

Series DU 40

914 PSI

Description:

Pressure filters changeover series DU 40 are suitable for operating pressure up to 914 PSI. The pressure peaks are absorbed by a sufficient margin of safety.

Duplex filters can be serviced without interruption of operation. The upper part has a three-way-changeover valve which allows to change-over the flow from the dirty filter-side to the clean filter-side without interrupting the operation. The changeover procedure does not lead to a cross sectional contraction. The closed filter-side has to be air-bleed by vent III respectively by vent IV. Then change filter element.

For cleaning the stainless steel mesh element or changing the filterer element, filter bowl has to be disassembled. The mesh elements are not guaranteed to maintain 100% performance after cleaning.

For filtration finer than 25 µm, use the disposable elements made of microglass. Filter elements as fine as 3 µm are available; finer filter elements are available upon request.

Eaton filter elements are known for high intrinsic stability and an excellent filtration capability, a high dirt-retaining capacity and a long service life.

Eaton filter are suitable for all petroleum based fluids, HW-emulsions, most synthetic hydraulic fluids and lubrication oils.

Type index:

Complete filter: (ordering example)

DU. 40. 10VG. 30. E. P. -. UG. 4. -. -. AE

1	2	3	4	5	6	7	8	9	10	11	12
---	---	---	---	---	---	---	---	---	----	----	----

- 1 | **series:**
DU = pressure filter change over
- 2 | **nominal size:** 40
- 3 | **filter material:**
80G, 40G, 25G, 10G stai nless steel wire mesh
25VG, 16VG, 10VG, 6VG, 3VG microglass
- 4 | **filter element collapse rating:**
30 = Δp 435 PSI
- 5 | **filter element design:**
E = single-end open
- 6 | **sealing material:**
P = Nitrile (NBR)
V = Viton (FPM)
- 7 | **filter element specification:**
- = standard
IS06 = for HFC application, see sheet-no. 31601
- 8 | **process connection:**
UG = thread connection
- 9 | **process connection size:**
3 = -10 SAE
4 = -12 SAE
- 10 | **filter housing specification:**
- = standard
IS06 = for HFC application, see sheet-no. 31605
- 11 | **specification pressure vessel:**
- = standard (PED 2014/68/EU)
- 12 | **clogging indicator or clogging sensor:**
- = without
AOR = visual, see sheet-no. 1606
AOC = visual, see sheet-no. 1606
AE = visual-electric, see sheet-no. 1615
VS5 = electronic, see sheet-no. 1619

To add an indicator/sensor to your filter, use the corresponding indicator data sheet to find the indicator details and add them to the filter assembly model code.

Filter element: (ordering example)

01NL. 40. 10VG. 30. E. P. -

1	2	3	4	5	6	7
---	---	---	---	---	---	---

- 1 | **series:**
01NL = standard filter element according to DIN 24550, T3
- 2 | **nominal size:** 40
- 3 | - 7 | see type index-complete filter

Accessories:

- gauge port- and bleeder connections, see sheet-no. 1650

Technical data:

max. operating temperature:	+14°F to +212°F
operating medium:	mineral oil, other media on request
max. operating pressure:	914 PSI
test pressure:	1300 PSI
standard process connection:	thread connection
housing material:	AL, carbon steel (filter bowl)
sealing material:	Nitrile (NBR) or Viton (FPM), other materials on request
installation position:	vertical
measure- and bleeder connections	BSPP ¼
volume tank:	2x .05 Gal.

Classified under the Pressure Equipment Directive 2014/68/EU for mineral oil (fluid group 2), Article 4, Para. 3.
 Classified under ATEX Directive 2014/34/EU according to specific application (see questionnaire sheet-no. 34279-4).

Pressure drop flow curves:

Filter calculation/sizing

The pressure drop of the assembly at a given flow rate Q is the sum of the housing Δp and the element Δp and is calculated as follows:

$$\Delta p_{assembly} = \Delta p_{housing} + \Delta p_{element}$$

$$\Delta p_{housing} = (\text{see } \Delta p = f(Q) - \text{characteristics})$$

$$\Delta p_{element} (PSI) = Q (GPM) \times \frac{MSK}{1000} \left(\frac{PSI}{GPM} \right) \times v (SUS) \times \frac{\rho}{0.876} \left(\frac{kg}{dm^3} \right)$$

For ease of calculation our Filter Selection tool is available online at www.eaton.com/hydraulic-filter-evaluation

Material gradient coefficients (MSK) for filter elements

The material gradient coefficients in psi/gpm apply to mineral oil (HLP) with a density of 0.876 kg/dm³ and a kinematic viscosity of 139 SUS (30 mm²/s). The pressure drop changes proportionally to the change in kinematic viscosity and density.

DU	VG					G			
	3VG	6VG	10VG	16VG	25VG	10G	25G	40G	80G
40	9.591	6.991	4.853	3.107	2.705	0.2553	0.1893	0.1766	0.1210

$\Delta p = f(Q)$ – characteristics according to ISO 3968

The pressure drop characteristics apply to mineral oil (HLP) with a density of 0.876 kg/dm³. The pressure drop changes proportionally to the density.

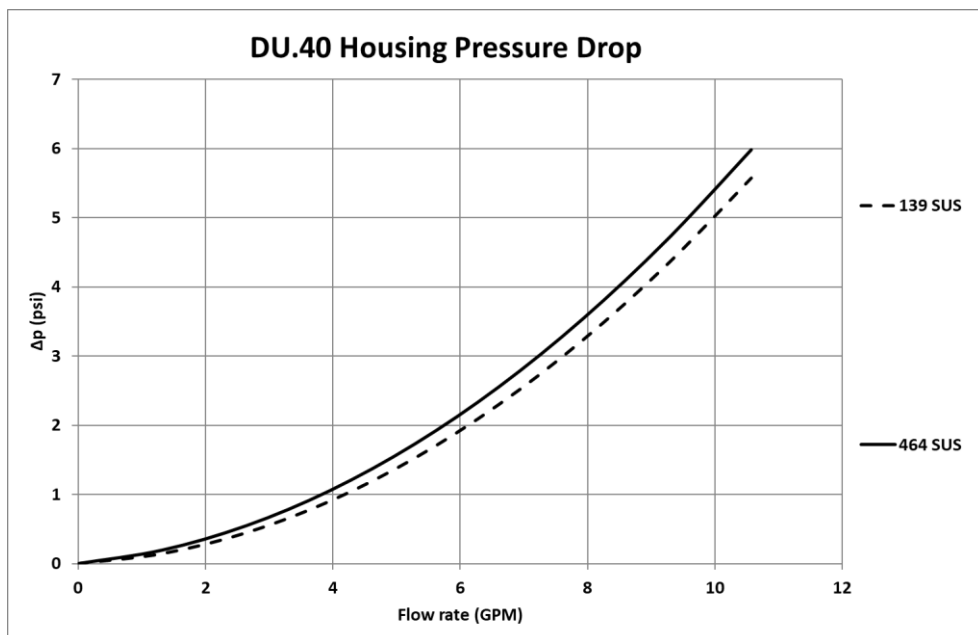

Symbols:

without indicator

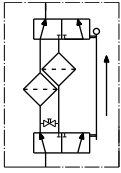

with electric indicator
AE 30 and AE 40

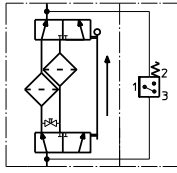

with visual-electric indicator
AE 50 and AE 62

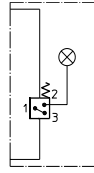

with visual-electric indicator
AE 70 and AE 80

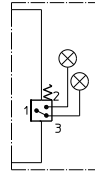

with visual indicator
AOR/AOC

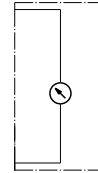

with electronic sensor
VS5

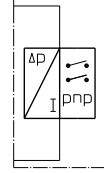

Spare parts:

item	qty.	designation	dimension	article-no.	
1	2	filter element	01NL.40...		
2	2	O-ring	22 x 3,5	304341 (NBR)	304392 (FPM)
3	2	O-ring	54 x 3	304657 (NBR)	304720 (FPM)
4	2	support ring	60 x 2,6 x 1	311779	
5	1	O-ring	23 x 3	307285 (NBR)	311019 (FPM)
6	1	support ring	28 x 23,6 x 1	350525	
7	1	O-ring	32,9 x 3,53	318850 (NBR)	338231 (FPM)
8	4	screw plug	BSPP ¼	305003	
9	2	screw plug	BSPP ½	304678	
10	1	clogging indicator, visual	AOR or AOC	see sheet-no. 1606	
11	1	clogging indicator, visual-electric	AE	see sheet-no. 1615	
12	1	clogging sensor, electronic	VS5	see sheet-no. 1619	
13	1	screw plug	20913-4	309817	

item 13 execution only without clogging indicator or clogging sensor

Test methods:

Filter elements are tested according to the following ISO standards:

ISO 2941	Verification of collapse/burst resistance
ISO 2942	Verification of fabrication integrity
ISO 2943	Verification of material compatibility with fluids
ISO 3723	Method for end load test
ISO 3724	Verification of flow fatigue characteristics
ISO 3968	Evaluation of pressure drop versus flow characteristics
ISO 16889	Multi-pass method for evaluating filtration performance

North America

44 Apple Street
Tinton Falls, NJ 07724
Toll Free: 800 656-3344
(North America only)
Tel: +1 732 212-4700

Europe/Africa/Middle East

Auf der Heide 2
53947 Nettersheim, Germany
Tel: +49 2486 809-0

Friedensstraße 41
68804 Altlußheim, Germany
Tel: +49 6205 2094-0

An den Nahewiesen 24
55450 Langenlonsheim, Germany
Tel: +49 6704 204-0

Greater China

No. 7, Lane 280,
Linhong Road
Changning District, 200335
Shanghai, P.R. China
Tel: +86 21 5200-0099

Asia-Pacific

100G Pasir Panjang Road
#07-08 Interlocal Centre
Singapore 118523
Tel: +65 6825-1668

For more information, please
email us at filtration@eaton.com
or visit www.eaton.com/filtration

© 2021 Eaton. All rights reserved. All trademarks and registered trademarks are the property of their respective owners. All information and recommendations appearing in this brochure concerning the use of products described herein are based on tests believed to be reliable. However, it is the user's responsibility to determine the suitability for his own use of such products. Since the actual use by others is beyond our control, no guarantee, expressed or implied, is made by Eaton as to the effects of such use or the results to be obtained. Eaton assumes no liability arising out of the use by others of such products. Nor is the information herein to be construed as absolutely complete, since additional information may be necessary or desirable when particular or exceptional conditions or circumstances exist or because of applicable laws or government regulations.