

Series DU 1050-2050

DN100 PN32

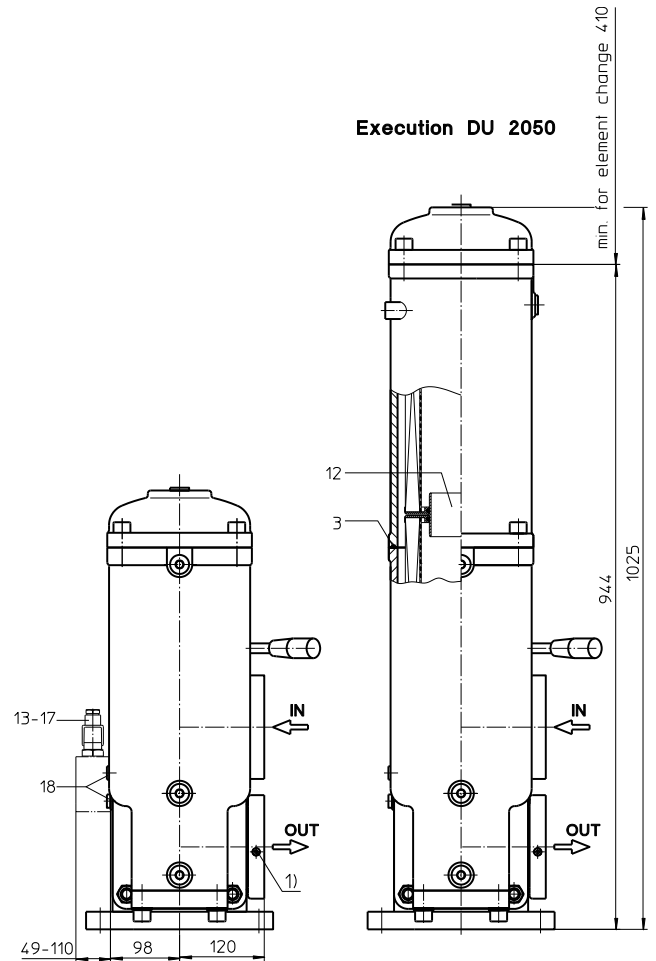
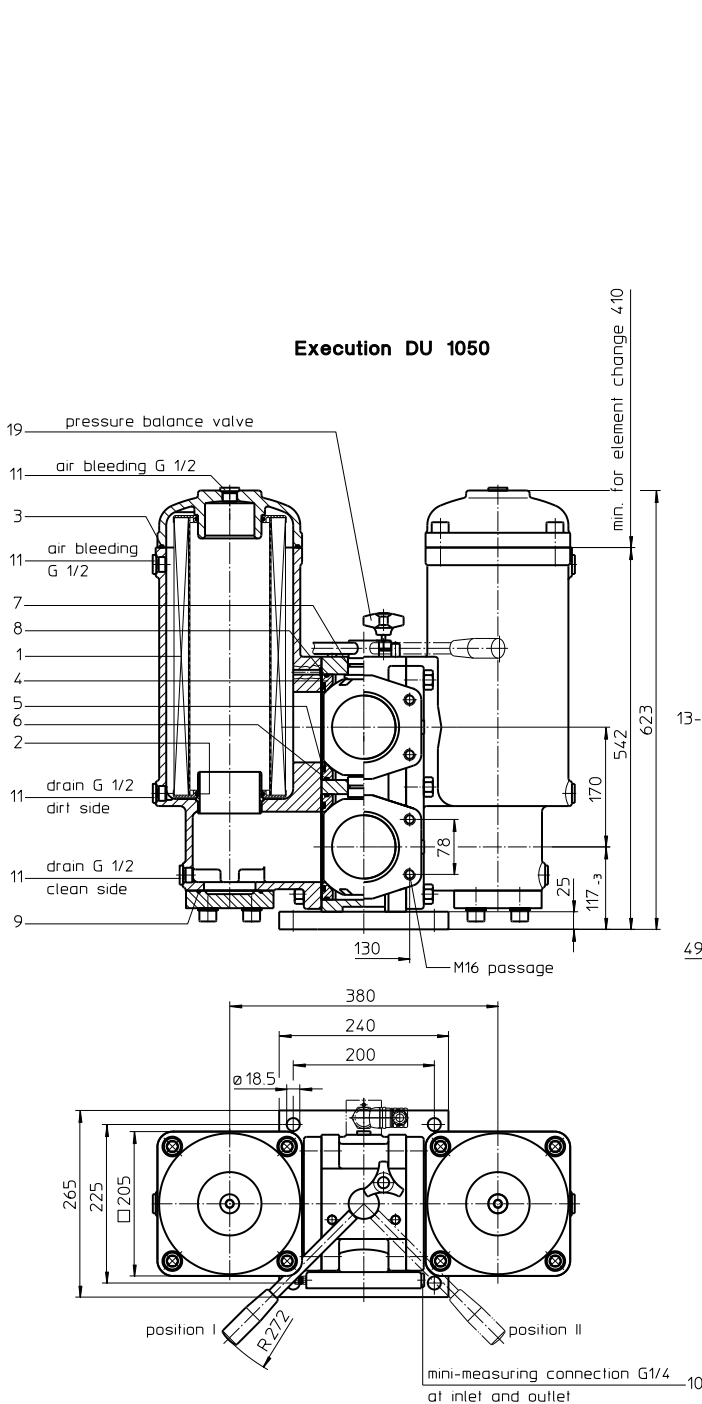

1) Connection for the potential equalization, only for application in the explosive area.

Position I: Left filter-side in operation
Position II: Right filter-side in operation

Weight DU1050: approx. 155 kg
Weight DU2050: approx. 195 kg

Dimensions: mm

Designs and performance values are subject to change.

Pressure Filter, change over Series DU 1050-2050 DN100 PN32

Description:

Pressure filter change over series DU 1050-2050 have a working pressure up to 32 bar. Pressure peaks can be absorbed with a sufficient safety margin.

A changeover ball valve between the two filter housings makes it possible to switch from the dirty filter side to the clean filter side without interrupting operation. These filters can be installed as suction filters.

The filter element consists of star-shaped, pleated filter material, which is supported on the inside by a perforated core tube and is bonded to the end caps with a high-quality adhesive. The flow direction is from outside to inside.

For cleaning the stainless steel mesh element (see special leaflets 21070-4 and 39448-4) or changing the filter element, remove the cover and take out the element. The mesh elements are not guaranteed to maintain 100% performance after cleaning.

For filtration finer than 40 µm, use the disposable elements made of microglass. Filter elements as fine as 5 µm(c) are available; finer filter elements are available upon request.

Eaton filter elements are known for a high intrinsic stability and an excellent filtration capability, a high dirt-retaining capacity and a long service life.

Eaton filter can be used for petroleum-based fluids, HW emulsions, water glycols, most synthetic fluids and lubrication fluids. Consult factory for specific fluid applications.

The internal valves are integrated in the filter cover. After reaching the bypass pressure setting, the bypass valve will send unfiltered partial flow around the filter.

Ship classifications available upon request.

Type index:

Complete filter: (ordering example)

DU.1050.10VG.10. B. P. -. FS. B. -. -. -. AE

1	2	3	4	5	6	7	8	9	10	11	12	13
---	---	---	---	---	---	---	---	---	----	----	----	----

- 1 | **series:**
DU = pressure filter, change over
- 2 | **nominal size:** 1050, 2050
- 3 | **filter-material:**
80G, 40G, 25G stainless steel wire mesh
25VG, 16VG, 10VG, 6VG, 3VG microglass
25API, 10API microglass according to API
10P paper
- 4 | **filter element collapse rating:**
10 = Δp 10 bar
- 5 | **filter element design:**
B = both sides open
- 6 | **sealing material:**
P = Nitrile (NBR)
V = Viton (FPM)
- 7 | **filter element specification:**
- = standard
VA = stainless steel
IS06 = for HFC application, see sheet-no. 31601
IS07 = for oil/amonia mixtures (NH₃), see sheet-no. 31602
- 8 | **process connection:**
FS = SAE-flange connection 3000 PSI
- 9 | **process connection size:**
B = 4"
A = 3" (with counter flange BFS.B.E.88,9x3,2....)
- 10 | **filter housing specification:**
- = standard
IS12 = internal parts of change over armature stainless steel, see sheet-no. 41028
- 11 | **pressure vessel specification:**
- = standard (PED 2014/68/EU)
IS20 = ASME VIII Div.1 with ASME equivalent material, see sheet-no. 55217 (max. operating pressure 16 bar)
IS14 = pressure vessel parts are calculated acc. to EN 13445 see sheet-no. 69828 (max. operating pressure 10 bar)
- 12 | **internal valve:**
- = without
S = with bypass valve Δp 2,0 bar
S1 = with bypass valve Δp 3,5 bar
- 13 | **clogging indicator or clogging sensor:**
- = without
AOR = visual, see sheet-no.1606
AOC = visual, see sheet-no.1606
AE = visual-electric, see sheet-no.1609
OP = visual, see sheet-no.1628
OE = visual-electric, see sheet-no.1628
VS5 = electronic, see sheet-no.1641

To add an indicator/sensor to your filter, use the corresponding indicator data sheet to find the indicator details and add them to the filter assembly model code.

Filter element: (ordering example)

01NR. 1000. 10VG. 10. B. P. -

1	2	3	4	5	6	7
---	---	---	---	---	---	---

- 1 | **series:**
01NR = standard-return-line filter element according to DIN 24550, T4
- 2 | **nominal size:** 1000, 1001 (only with DU2050)
- 3 | **- 7** | see type index complete filter

Accessories:

- gauge port and bleeder connection, see sheet-no. 1650
- drain- and bleeder connection, see sheet-no. 1651
- SAE-counter flanges, see sheet-no. 1652
- shut-off valve, see sheet-no. 1655

Technical data:

operating temperature:	-10°C to +100°C
operating medium:	mineral oil, other media on request
max. operating pressure:	32 bar
test pressure:	64 bar
max. operating pressure with IS20:	16 bar
test pressure with IS20:	32 bar
max. operating pressure with IS14:	10 bar
test pressure with IS14:	20 bar
process connection:	SAE-flange connection 3000 PSI
housing material:	EN-GJS-400-18-LT
sealing material:	Nitrile (NBR) or Viton (FPM), other materials on request
installation position:	vertical
measuring connections:	G ¼
drain- and bleeder connections:	G ½
volume tank DU1050:	2x 13,7 l
volume tank DU2050:	2x 23,9 l

Classified under the Pressure Equipment Directive 2014/68/EU for mineral oil (fluid group 2), Article 4, Para. 3.
 Classified under ATEX Directive 2014/34/EU according to specific application (see questionnaire sheet-no. 34279-4).

Pressure drop flow curves:

Filter calculation/sizing

The pressure drop of the assembly at a given flow rate Q is the sum of the housing Δp and the element Δp and is calculated as follows:

$$\Delta p_{assembly} = \Delta p_{housing} + \Delta p_{element}$$

$$\Delta p_{housing} = (\text{see } \Delta p = f(Q) \text{ - characteristics})$$

$$\Delta p_{Element} (mbar) = Q \left(\frac{l}{min} \right) \times \frac{MSK}{10} \left(\frac{mbar}{l/min} \right) \times v \left(\frac{mm^2}{s} \right) \times \frac{p}{0,876} \left(\frac{kg}{dm^3} \right)$$

For ease of calculation our Filter Selection tool is available online at www.eaton.com/hydraulic-filter-evaluation

Material gradient coefficients (MSK) for filter elements

The material gradient coefficients in mbar/(l/min) apply to mineral oil (HLP) with a density of 0,876 kg/dm³ and a kinematic viscosity of 30 mm²/s (139 SUS). The pressure drop changes proportionally to the change in kinematic viscosity and density.

DU	VG					G			P	API	
	3VG	6VG	10VG	16VG	25VG	25G	40G	80G	10P	10API	25API
1050	0,197	0,137	0,087	0,076	0,052	0,0050	0,0046	0,0032	0,042	0,044	0,020
2050	0,098	0,068	0,044	0,038	0,026	0,0025	0,0023	0,0016	0,021	0,022	0,010

$\Delta p = f(Q)$ – characteristics according to ISO 3968

The pressure drop characteristics apply to mineral oil (HLP) with a density of 0,876 kg/dm³. The pressure drop changes proportionally to the density.

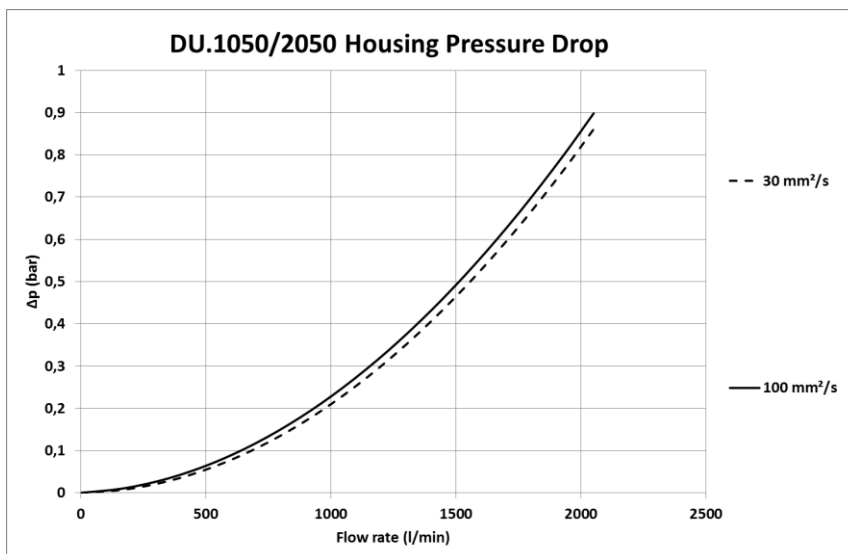

Symbols:

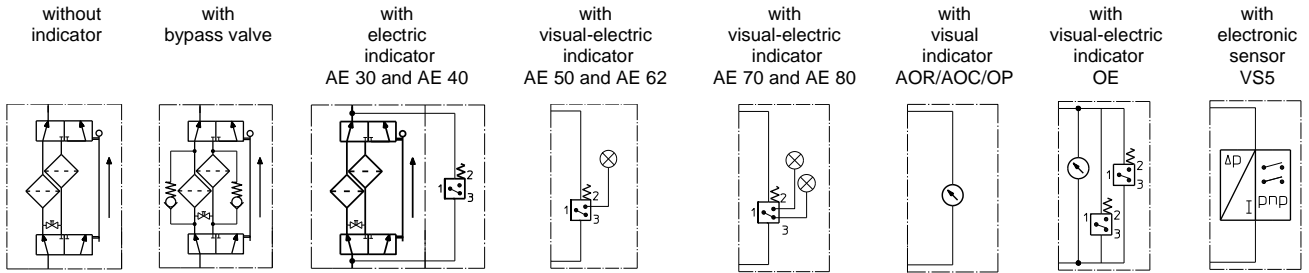

Spare parts:

item	qty.	designation	dimension		article-no.	
			DU 1050	DU 2050		
1	2	filte relement (DU1050)	01NR.1000...	01NR.1000...or 1001		
	4	filter element (DU2050)	01NR.1000...	01NR.1000...or 1001		
2	4	O-ring (DU1050)	90 x 4		306941 (NBR)	307031 (FPM)
	8	O-ring (DU2050)	90 x 4		306941 (NBR)	307031 (FPM)
3	2	O-ring (DU1050)	185 x 4		305593 (NBR)	306309 (FPM)
	4	O-ring (DU2050)	185 x 4		305593 (NBR)	306309 (FPM)
4	4	gasket	DN 100		312275	
5	4	O-ring	114 x 6		314419 (NBR)	316531 (FPM)
6	4	O-ring	140 x 4		305145 (NBR)	305201 (FPM)
7	2	O-ring	38 x 3		304340 (NBR)	317013 (FPM)
8	4	O-ring	8 x 2		310004 (NBR)	316530 (FPM)
9	2	O-ring	85,32 x 3,53		305590 (NBR)	306308 (FPM)
10	2	screw plug	G ¼		305003	
11	8	screw plug (DU1050)	G ½		304678	
	10	screw plug (DU2050)	G ½		304678	
12	2	connecting pipe (DU2050)	Ø 90		313233	
13	1	clogging indicator, visual	AOR or AOC		see sheet no. 1606	
14	1	clogging indicator, visual r, optisch	OP		see sheet no. 1628	
15	1	clogging indicator, visual-electric	OE		see sheet no. 1628	
16	1	clogging indicator, visual-electric	AE		see sheet no. 1609	
17	1	clogging sensor, electronic	VS5		see sheet no. 1641	
18	2	screw plug	G ¼		305003	
19	1	pressure balance valve	DN10		305000	

item 18 execution only without clogging indicator or clogging sensor

Test methods:

Filter elements are tested according to the following ISO standards:

ISO 2941	Verification of collapse/burst resistance
ISO 2942	Verification of fabrication integrity
ISO 2943	Verification of material compatibility with fluids
ISO 3723	Method for end load test
ISO 3724	Verification of flow fatigue characteristics
ISO 3968	Evaluation of pressure drop versus flow characteristics
ISO 16889	Multi-pass method for evaluating filtration performance

North America

44 Apple Street
Tinton Falls, NJ 07724
Toll Free: 800 656-3344
(North America only)
Tel: +1 732 212-4700

Greater China

No. 7, Lane 280,
Linhong Road
Changning District, 200335
Shanghai, P.R. China
Tel: +86 21 5200-0099

Europe/Africa/Middle East

Auf der Heide 2
53947 Nettersheim, Germany
Tel: +49 2486 809-0

Friedensstraße 41
68804 Altlußheim, Germany
Tel: +49 6205 2094-0

An den Nahewiesen 24
55450 Langenlonsheim, Germany
Tel: +49 6704 204-0

Asia-Pacific

100G Pasir Panjang Road
#07-08 Interlocal Centre
Singapore 118523
Tel: +65 6825-1668

For more information, please

email us at filtration@eaton.com

or visit www.eaton.com/filtration

© 2021 Eaton. All rights reserved. All trademarks and registered trademarks are the property of their respective owners. All information and recommendations appearing in this brochure concerning the use of products described herein are based on tests believed to be reliable. However, it is the user's responsibility to determine the suitability for his own use of such products. Since the actual use by others is beyond our control, no guarantee, expressed or implied, is made by Eaton as to the effects of such use or the results to be obtained. Eaton assumes no liability arising out of the use by others of such products. Nor is the information herein to be construed as absolutely complete, since additional information may be necessary or desirable when particular or exceptional conditions or circumstances exist or because of applicable laws or government regulations.

EATON

Powering Business Worldwide