

Series DU 2005-4005

464 PSI

Assignment of connections and functions:

- A: process inlet SAE 5" 3000 PSI
- B: process outlet SAE 5" 3000 PSI
- C1/C2: air bleeding BSPP 1/2
- D1/D2: drain BSPP 1/2, dirt side
- E1/E2: drain BSPP 1/2, clean side
- F1/F2: air bleeding BSPP 1/2

Switch lever standard in the front.

- 2) On request: The switch lever can be moved to backside of the changeover valve, opposite to the inlet and outlet.

Please specify this configuration on the order.

- Position I: Left filter-side in operation
- Position II: Right filter-side in operation

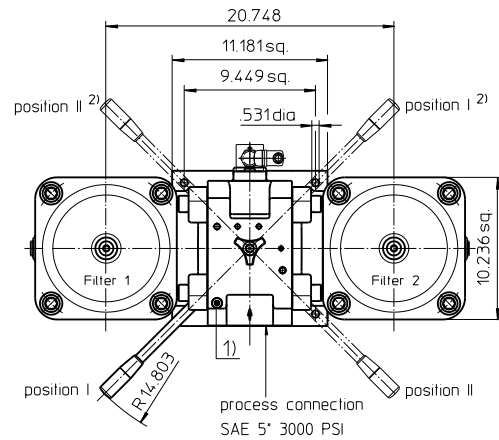

- 1) Connection for the potential equalization, only for application in the explosive area.

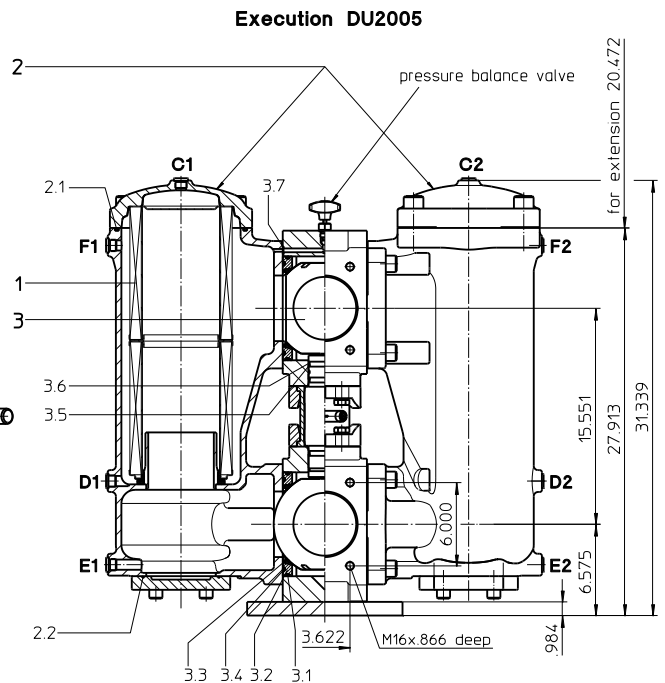
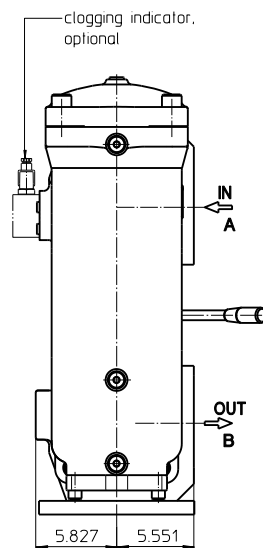
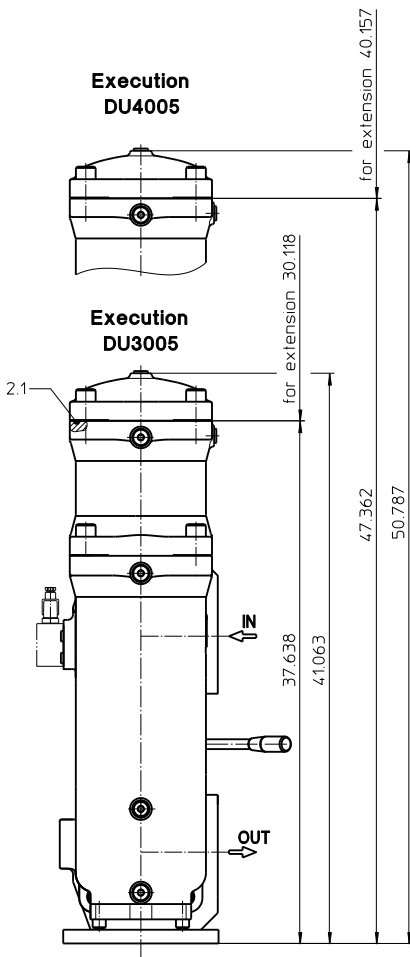

Weight DU2005: approx. 754 lbs.
 Weight DU3005: approx. 893 lbs.
 Weight DU4005: approx. 970 lbs.

Dimensions: inches

Designs and performance values are subject to change.

Pressure Filter, changeover Series DU 2005-4005 464 PSI

Description:

Pressure filter, change over series DU 2005-4005 have a working pressure up to 464 PSI. Pressure peaks can be absorbed with a sufficient safety margin.

A changeover ball valve between the two filter housings makes it possible to switch from the dirty filter side to the clean filter side without interrupting operation. These filters can be installed as suction filters.

The filter element consists of star-shaped, pleated filter material, which is supported on the inside by a perforated core tube and is bonded to the end caps with a high-quality adhesive. The flow direction is from outside to inside.

For cleaning the stainless steel mesh element (see special leaflets 21070-4 and 39448-4) or changing the filter element, remove the cover and take out the element. The mesh elements are not guaranteed to maintain 100% performance after cleaning.

For filtration finer than 40 µm, use the disposable elements made of microglass. Filter elements as fine as 5 µm(c) are available; finer filter elements are available upon request.

Eaton filter elements are known for a high intrinsic stability and an excellent filtration capability, a high dirt-retaining capacity and a long service life.

Eaton filter can be used for petroleum-based fluids, HW emulsions, water glycols, most synthetic fluids and lubrication fluids. Consult factory for specific fluid applications.

Ship classifications available upon request.

Type index:

Complete filter: (ordering example)

DU.2005.10VG.10. E. P. -. FS. C. -. -. -. AE

1	2	3	4	5	6	7	8	9	10	11	12	13
---	---	---	---	---	---	---	---	---	----	----	----	----

- 1 series:**
DU = pressure filter, changeover
- 2 nominal size:** 2005, 3005, 4005
- 3 filter-material:**
80G, 40G, 25G stainless steel wire mesh
25VG, 16VG, 10VG, 6VG, 3VG microglass
25API, 10API microglass according to API
10P paper
- 4 filter element collapse rating:**
10 = Δp 145 PSI
- 5 filter element design:**
E = without by-pass valve
S = with by-pass valve Δp 29 PSI
S1 = with by-pass valve Δp 51 PSI
- 6 sealing material:**
P = Nitrile (NBR)
V = Viton (FPM)
- 7 filter element specification:**
- = standard
VA = stainless steel
IS06 = for HFC application, see sheet-no. 31601
- 8 process connection:**
FS = SAE-flange connection 3000 PSI
- 9 process connection size:**
C = 5"
- 10 filter housing specification:**
- = standard
IS12 = internal parts of change over armature stainless steel, see sheet-no. 41028
- 11 pressure vessel specification:**
- = standard (PED 2014/68/EU)
IS20 = ASME VIII Div.1 with ASME equivalent material, see sheet-no. 55217 (max. operating pressure 232 PSI)
IS14 = pressure vessel parts are calculated acc. to EN 13445 see sheet-no. 69828 (max. operating pressure 145 PSI)
IS63 = for operating pressure to 914 PSI, see sheet-no. 68796
- 12 internal valve:**
- = without
- 13 clogging indicator or clogging sensor:**
- = without
AOR = visual, see sheet-no.1606
AOC = visual, see sheet-no.1606
AE = visual-electric, see sheet-no.1609
OP = visual, see sheet-no.1628
OE = visual-electric, see sheet-no.1628
VS5 = electronic, see sheet-no.1641

To add an indicator/sensor to your filter, use the corresponding indicator data sheet to find the indicator details and add them to the filter assembly model code.

Filter element: (ordering example)

01E. 2001. 10VG. 10. E. P. -

1	2	3	4	5	6	7
---	---	---	---	---	---	---

- 1 series:**
01E = filter element according to company standard
- 2 nominal size:** 2001, 3001, 4001
- 3 - 7** see type index complete filter

Accessories:

- gauge port and bleeder connection, see sheet-no. 1650
- drain- and bleeder connection, see sheet-no. 1651
- SAE-counter flanges, see sheet-no. 1652
- shut-off valve, see sheet-no. 1655

Technical data:

operating temperature:	+14 °F to +212 °F
operating medium:	mineral oil, other media on request
max. operating pressure:	464 PSI
test pressure:	900 PSI
max. operating pressure with IS20:	232 PSI
test pressure with IS20:	464 PSI
max. operating pressure with IS14:	145 PSI
test pressure with IS14:	290 PSI
max. operating pressure with IS63:	914 PSI
test pressure with IS63:	1827 PSI
process connection:	SAE-flange connection 3000 PSI
housing material:	EN-GJS-400-18-LT
sealing material:	Nitrile (NBR) or Viton (FPM), other materials on request
installation position:	vertical
measuring connections:	BSPP ¼
drain- and bleeder connections:	BSPP ½
volume tank DU2005:	2x 7.6 Gal.
volume tank DU3005:	2x 10.0 Gal.
volume tank DU4005:	2x 12.5 Gal.

Classified under the Pressure Equipment Directive 2014/68/EU for mineral oil (fluid group 2), Article 4, Para. 3.
 Classified under ATEX Directive 2014/34/EU according to specific application (see questionnaire sheet-no. 34279-4).

Pressure drop flow curves:

Filter calculation/sizing

The pressure drop of the assembly at a given flow rate Q is the sum of the housing Δp and the element Δp and is calculated as follows:

$$\Delta p_{assembly} = \Delta p_{housing} + \Delta p_{element}$$

$$\Delta p_{housing} = (\text{see } \Delta p = f(Q) - \text{characteristics})$$

$$\Delta p_{element} (PSI) = Q (GPM) \times \frac{MSK}{1000} \left(\frac{PSI}{GPM} \right) \times v (SUS) \times \frac{\rho}{0.876} \left(\frac{kg}{dm^3} \right)$$

For ease of calculation our Filter Selection tool is available online at: www.eaton.com/hydraulic-filter-evaluation

Material gradient coefficients (MSK) for filter elements

The material gradient coefficients in psi/gpm apply to mineral oil (HLP) with a density of 0.876 kg/dm³ and a kinematic viscosity of 139 SUS (30 mm²/s). The pressure drop changes proportionally to the change in kinematic viscosity and density.

DU	VG					G			P	API	
	3VG	6VG	10VG	16VG	25VG	25G	40G	80G	10P	10API	25API
2005	0.177	0.123	0.079	0.068	0.047	0.0059	0.0055	0.0038	0.041	0.040	0.018
3005	0.118	0.082	0.052	0.046	0.031	0.0040	0.0037	0.0025	0.027	0.027	0.012
4005	0.088	0.061	0.039	0.034	0.023	0.0030	0.0028	0.0019	0.020	0.020	0.009

$\Delta p = f(Q)$ - characteristics according to ISO 3968

The pressure drop characteristics apply to mineral oil (HLP) with a density of 0.876 kg/dm³. The pressure drop changes proportionally to the density.

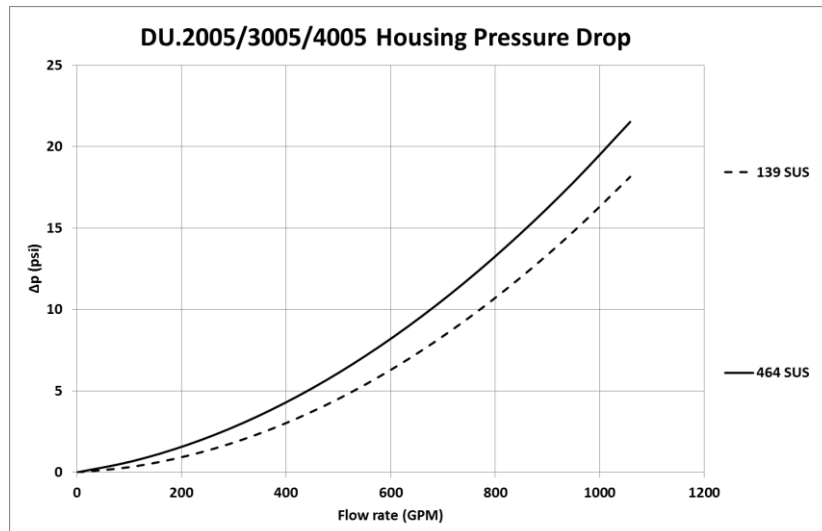

Symbols:

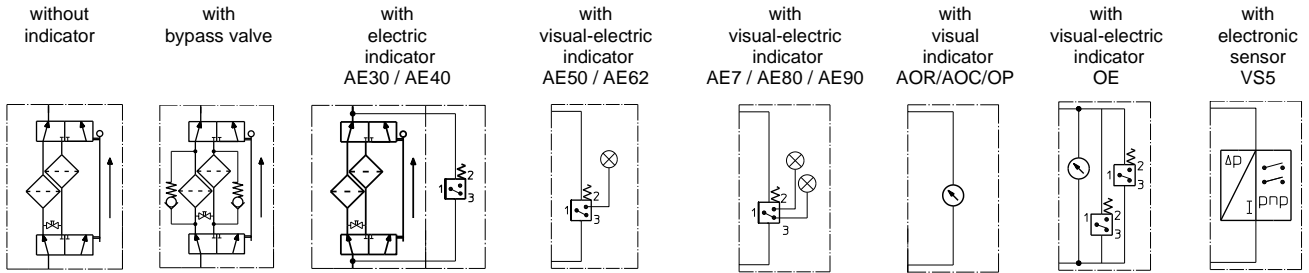

Spare parts:

item	qty.	designation	dimension			article-no.	
			DU 2005	DU 3005	DU 4005		
1	2	filter element	01.E2001...	01.E3001...	01.E4001...		
2		gaskets for filter housing					
2.1	2	O-ring (DU2005)		240 x 5		307592 (NBR)	328793 (FPM)
	4	O-ring (DU3005/4005)		240 x 5		307592 (NBR)	328793 (FPM)
2.2	2	O-ring		136,12 x 3,53		320162 (NBR)	320163 (FPM)
3	1	gasket kit of switching over consisting of:		5" (DN125)		322726 (NBR)	322727 (FPM)
3.1	4	O-ring		175 x 5			
3.2	4	O-ring		160 x 5			
3.3	4	O-ring		135 x 3			
3.4	4	gasket ring		5" (DN125)			
3.5	4	O-ring		53 x 3,55			
3.6	4	support ring		60 x 54,9 x 5			
3.7	2	O-ring		10 x 2			

Test methods:

Filter elements are tested according to the following ISO standards:

ISO 2941	Verification of collapse/burst resistance
ISO 2942	Verification of fabrication integrity
ISO 2943	Verification of material compatibility with fluids
ISO 3723	Method for end load test
ISO 3724	Verification of flow fatigue characteristics
ISO 3968	Evaluation of pressure drop versus flow characteristics
ISO 16889	Multi-pass method for evaluating filtration performance

North America
44 Apple Street
Tinton Falls, NJ 07724
Toll Free: 800 656-3344
(North America only)
Tel: +1 732 212-4700

Greater China
No. 7, Lane 280,
Linhong Road
Changning District, 200335
Shanghai, P.R. China
Tel: +86 21 5200-0099

Europe/Africa/Middle East
Auf der Heide 2
53947 Nettersheim, Germany
Tel: +49 2486 809-0

Friedensstraße 41
68804 Altlußheim, Germany
Tel: +49 6205 2094-0

Asia-Pacific
100G Pasir Panjang Road
#07-08 Interlocal Centre
Singapore 118523
Tel: +65 6825-1668

An den Nahewiesen 24
55450 Langenlonsheim, Germany
Tel: +49 6704 204-0

**For more information, please
email us at filtration@eaton.com
or visit www.eaton.com/filtration**

© 2021 Eaton. All rights reserved. All trademarks and registered trademarks are the property of their respective owners. All information and recommendations appearing in this brochure concerning the use of products described herein are based on tests believed to be reliable. However, it is the user's responsibility to determine the suitability for his own use of such products. Since the actual use by others is beyond our control, no guarantee, expressed or implied, is made by Eaton as to the effects of such use or the results to be obtained. Eaton assumes no liability arising out of the use by others of such products. Nor is the information herein to be construed as absolutely complete, since additional information may be necessary or desirable when particular or exceptional conditions or circumstances exist or because of applicable laws or government regulations.