

# Series DU 101

## 464 PSI

**Assignment of connections and functions:**

- A: process inlet SAE 1 1/4" 3000 PSI
- B: process outlet SAE 1 1/4" 3000 PSI
- C1/C2: air bleeding BSPP 1/2
- D1/D2: drain BSPP 1/2, dirt side
- E1/E2: drain BSPP 1/2, clean side
- F1: measuring connection BSPP 1/4, dirt side
- F2: measuring connection BSPP 1/4, clean side
- G1/G2: air bleeding BSPP 1/2

Position I: Left filter-side in operation  
 Position II: Right filter-side in operation

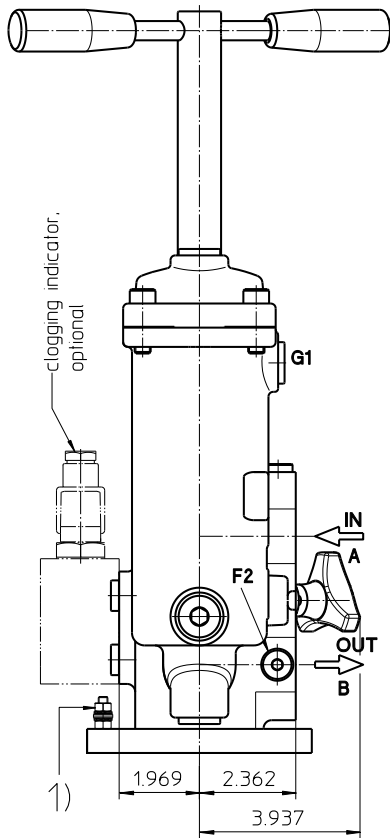
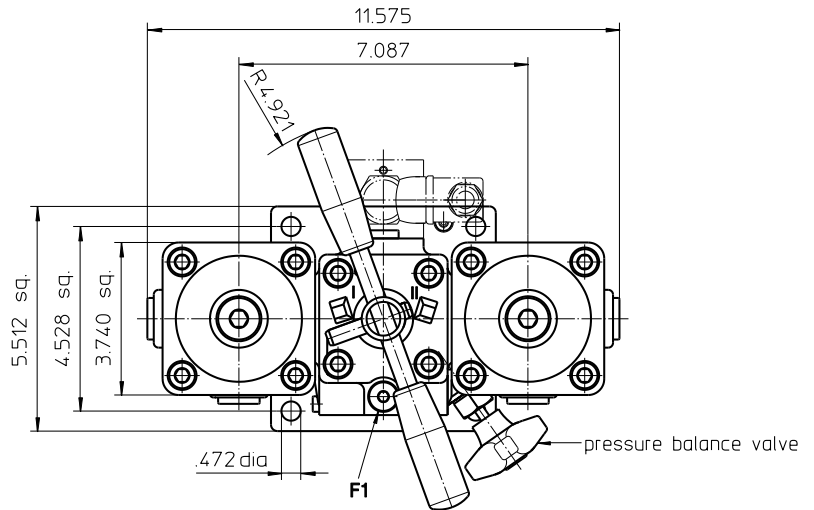

1) Connection for the potential equalization, only for application in the explosive area.

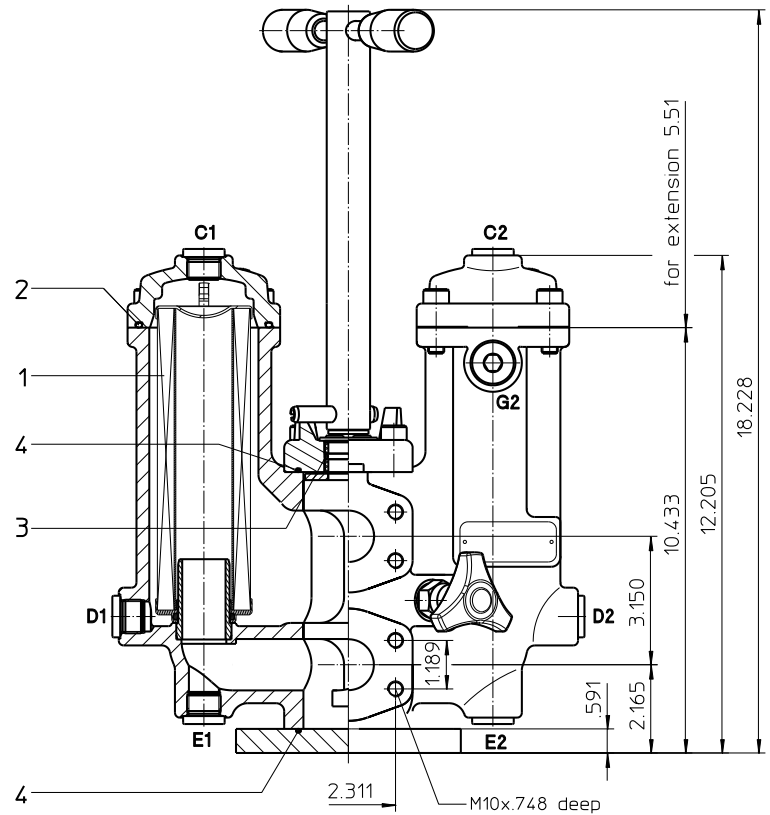

weight: approx. 51 lbs.

Dimensions: inches

Designs and performance values are subject to change.



Powering Business Worldwide

# Pressure Filter, changeover Series DU 101 464 PSI

## Description:

Pressure filter, change over series DU 101 have a working pressure up to 464 PSI. Pressure peaks can be absorbed with a sufficient safety margin.

A three-way-change-over valve which is integrated in the middle of the housing makes it possible to switch from the dirty filter-side to the clean filter-side without interrupting operation. These filters can be installed as suction filters.

The filter element consists of star-shaped, pleated filter material, which is supported on the inside by a perforated core tube and is bonded to the end caps with a high-quality adhesive. The flow direction is from outside to inside.

For cleaning the stainless steel mesh element or changing the filterer element, remove the cover and take out the element. The mesh elements are not guaranteed to maintain 100% performance after cleaning.

For filtration finer than 40 µm, use the disposable elements made of microglass. Filter elements as fine as 5 µm(c) are available; finer filter elements are available upon request.

Eaton filter elements are known for a high intrinsic stability and an excellent filtration capability, a high dirt-retaining capacity and a long service life.

Eaton filter can be used for petroleum-based fluids, HW emulsions, water glycols, most synthetic fluids and lubrication fluids. Consult factory for specific fluid applications.

Ship classifications available upon request.

## Type index:

**Complete filter:** (ordering example)

<b>DU. 101.</b>	<b>10VG.</b>	<b>16.</b>	<b>E.</b>	<b>P.</b>	<b>-.</b>	<b>FS.</b>	<b>6.</b>	<b>-.</b>	<b>-.</b>	<b>-.</b>	<b>AE</b>	
1	2	3	4	5	6	7	8	9	10	11	12	13

**1 series:**

DU = pressure filter, changeover

**2 nominal size:** 101

**3 filter-material:**

80G, 40G, 25G stainless steel wire mesh  
25VG, 16VG, 10VG, 6VG, 3VG microglass  
25API, 10API microglass according to API  
10P paper

**4 filter element collapse rating:**

16 = Δp 232 PSI

**5 filter element design:**

E = single end open  
S = with bypass valve Δp 29 PSI  
S1 = with bypass valve Δp 51 PSI

**6 sealing material:**

P = Nitrile (NBR)  
V = Viton (FPM)

**7 filter element specification:**

- = standard  
VA = stainless steel  
IS06 = for HFC application, see sheet-no. 31601

**8 process connection:**

FS = SAE-flange connection 3000 PSI

**9 process connection size:**

6 = 1 ¼" (standard)  
5 = 1" (with counter flange BFS.6.A.33,7x2,6.ST.P.3000)

**10 filter housing specification:**

- = standard  
IS12 = internal parts of change over armature stainless steel, see sheet-no. 41028

**11 pressure vessel specification:**

- = standard (PED 2014/68/EU)  
IS20 = ASME VIII Div.1 with ASME equivalent material, see sheet-no. 55217 (max. operating pressure 232 PSI)  
IS63 = for operating pressure to 914 PSI, see sheet-no. 68796

**12 internal valve:**

- = without

**13 clogging indicator or clogging sensor:**

- = without  
AOR = visual, see sheet-no.1606  
AOC = visual, see sheet-no.1606  
AE = visual-electric, see sheet-no.1609  
OP = visual, see sheet-no.1628  
OE = visual-electric, see sheet-no.1628  
VS5 = electronic, see sheet-no.1641

To add an indicator/sensor to your filter, use the corresponding indicator data sheet to find the indicator details and add them to the filter assembly model code.

**Filter element:** (ordering example)

<b>01N.</b>	<b>100.</b>	<b>10VG.</b>	<b>16.</b>	<b>E.</b>	<b>P.</b>	<b>-</b>
1	2	3	4	5	6	7

**1 series:**

01N = filter element according to company standard

**2 nominal size:** 100

**3 - 7** see type index complete filter

## Accessories:

- gauge port and bleeder connection, see sheet-no. 1650
- drain- and bleeder connection, see sheet-no. 1651 resp. 1659
- SAE-counter flanges, see sheet-no. 1652
- shut-off valve, see sheet-no. 1655

## Technical data:

operating temperature:	+14°F to +212°F
operating medium:	mineral oil, other media on request
max. operating pressure:	464 PSI
test pressure:	900 PSI
max. operating pressure with IS20:	232 PSI
test pressure with IS20:	464 PSI
max. operating pressure with IS63:	914 PSI
test pressure with IS63:	1827 PSI
process connection:	SAE-flange connection 3000 PSI
housing material:	EN-GJS-400-18-LT
sealing material:	Nitrile (NBR) or Viton (FPM), other materials on request
installation position:	vertical
measuring connections:	BSPP ¼
drain- and bleeder connections:	BSPP ½
volume tank:	2x .23 Gal.

Classified under the Pressure Equipment Directive 2014/68/EU for mineral oil (fluid group 2), Article 4, Para. 3.  
Classified under ATEX Directive 2014/34/EU according to specific application (see questionnaire sheet-no. 34279-4).

## Pressure drop flow curves:

### Filter calculation/sizing

The pressure drop of the assembly at a given flow rate Q is the sum of the housing  $\Delta p$  and the element  $\Delta p$  and is calculated as follows:

$$\Delta p_{assembly} = \Delta p_{housing} + \Delta p_{element}$$

$$\Delta p_{housing} = (\text{see } \Delta p = f(Q) \text{ - characteristics})$$

$$\Delta p_{element} (PSI) = Q (GPM) \times \frac{MSK}{1000} \left( \frac{PSI}{GPM} \right) \times \nu (SUS) \times \frac{\rho}{0.876} \left( \frac{kg}{dm^3} \right)$$

For ease of calculation our Filter Selection tool is available online at: [www.eaton.com/hydraulic-filter-evaluation](http://www.eaton.com/hydraulic-filter-evaluation)

### Material gradient coefficients (MSK) for filter elements

The material gradient coefficients in psi/gpm apply to mineral oil (HLP) with a density of 0.876 kg/dm<sup>3</sup> and a kinematic viscosity of 139 SUS (30 mm<sup>2</sup>/s). The pressure drop changes proportionally to the change in kinematic viscosity and density.

DU	VG					G			P	API	
	3VG	6VG	10VG	16VG	25VG	25G	40G	80G	10P	10API	25API
101	2.473	1.717	1.099	0.957	0.654	0.0651	0.0607	0.0416	0.504	0.582	0.266

### $\Delta p = f(Q)$ – characteristics according to ISO 3968

The pressure drop characteristics apply to mineral oil (HLP) with a density of 0.876 kg/dm<sup>3</sup>. The pressure drop changes proportionally to the density.

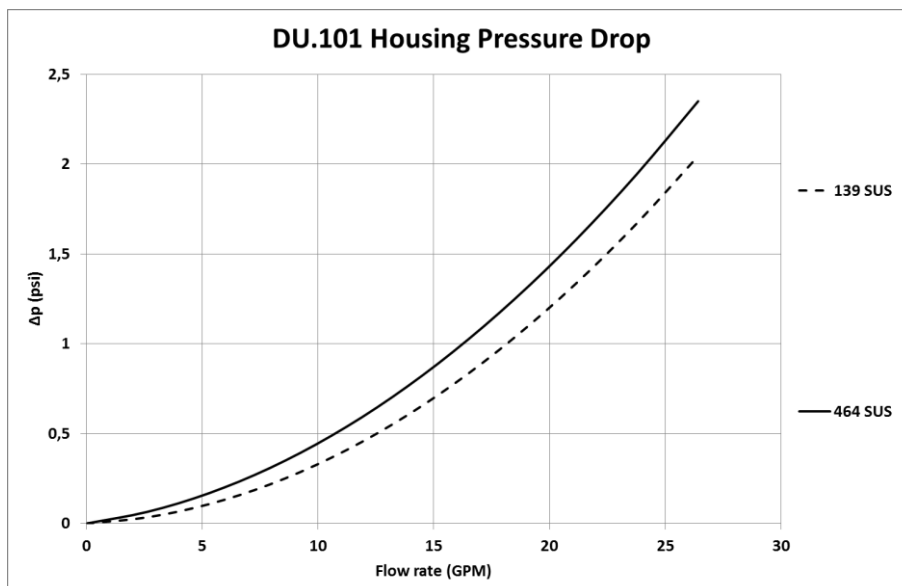

## Symbols:

without indicator

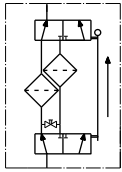

with electric indicator  
AE30 / AE40

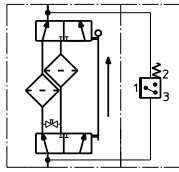

with visual-electric indicator  
AE50 / AE62

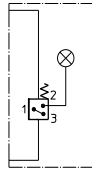

with visual-electric indicator  
AE70 / AE80 / AE90

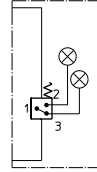

with visual indicator  
AOR/AOC/OP

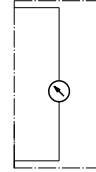

with visual-electric indicator  
OE

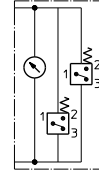

with electronic sensor  
VS5

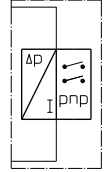

## Spare parts:

item	qty.	designation	dimension	article-no.	
1	2	filter element	01.N100...		
2	2	O-ring	76 x 4	305599 (NBR)	310291 (FPM)
3	1	O-ring	24 x 3	303038 (NBR)	304397 (FPM)
4	2	O-ring	60 x 2,5	305601 (NBR)	310267 (FPM)

## Test methods:

Filter elements are tested according to the following ISO standards:

ISO 2941	Verification of collapse/burst resistance
ISO 2942	Verification of fabrication integrity
ISO 2943	Verification of material compatibility with fluids
ISO 3723	Method for end load test
ISO 3724	Verification of flow fatigue characteristics
ISO 3968	Evaluation of pressure drop versus flow characteristics
ISO 16889	Multi-pass method for evaluating filtration performance

**North America**  
44 Apple Street  
Tinton Falls, NJ 07724  
Toll Free: 800 656-3344  
(North America only)  
Tel: +1 732 212-4700

**Greater China**  
No. 7, Lane 280,  
Linhong Road  
Changning District, 200335  
Shanghai, P.R. China  
Tel: +86 21 5200-0099

**Europe/Africa/Middle East**  
Auf der Heide 2  
53947 Nettersheim, Germany  
Tel: +49 2486 809-0

**Asia-Pacific**  
100G Pasir Panjang Road  
#07-08 Interlocal Centre  
Singapore 118523  
Tel: +65 6825-1668

Friedensstraße 41  
68804 Altlufheim, Germany  
Tel: +49 6205 2094-0

An den Nahewiesen 24  
55450 Langenlonsheim, Germany  
Tel: +49 6704 204-0

**For more information, please  
email us at [filtration@eaton.com](mailto:filtration@eaton.com)  
or visit [www.eaton.com/filtration](http://www.eaton.com/filtration)**

© 2021 Eaton. All rights reserved. All trademarks and registered trademarks are the property of their respective owners. All information and recommendations appearing in this brochure concerning the use of products described herein are based on tests believed to be reliable. However, it is the user's responsibility to determine the suitability for his own use of such products. Since the actual use by others is beyond our control, no guarantee, expressed or implied, is made by Eaton as to the effects of such use or the results to be obtained. Eaton assumes no liability arising out of the use by others of such products. Nor is the information herein to be construed as absolutely complete, since additional information may be necessary or desirable when particular or exceptional conditions or circumstances exist or because of applicable laws or government regulations.