

This manual is effective for all filters of the type DU40 and related specifications. It contains certain requirements and instructions which ensure unobjectionable operation of the filter. It can be completed with specific additional instructions by the operator himself if necessary.

1. Safety instructions

- The operating and maintenance instructions must be read carefully before working on the filter.
- The instructions in this manual must be followed!
- The manufacturer assumes no liability for damage caused by deviations from this manual..
- If actions are performed differently than described, the safety of the pressure equipment is not guaranteed!
- The operating parameters specified in the data sheet, in particular operating pressure, operating temperature range and operating medium, must be observed. Deviations from these parameters can damage pressure-bearing parts and seals. The compatibility of the filter components with the operating medium must be observed.
- The filter is under pressure in the operating state. No components of the filter may be loosened or removed during operation. Operating medium can escape under high pressure and at high temperature.
This does not include components on the pressure-relieved or switched-off side of the housing.
- There is a risk of injury and scalding from the operating medium escaping!
- The filter housing must not be opened before it is ensured that it is no longer under pressure!
- Touching components of the filter can cause burns, depending on the operating temperature.
- Attention when changing the filter elements! Filter housing might still have operating temperature. Risk of burn!
- Always wear protective gloves and safety glasses when working on the filter!
- If you come into contact with the operating medium, the manufacturer's instructions must be observed!
- Only original spare parts may be used.

For filters being used in hazardous locations the Eaton documentation N° 41269 "Supplementation of the Operating Manual for the use of filters in potential explosive areas.

2. Assembly

The filter is delivered ready for installation. The filter has to be fitted according to the fitting position the corresponding data sheet on a flat vertical surface.

The fitting of the filter has to be carried out in the way that the least possible transmission of tensile forces on the filter housing is given.

Ensure upon assembling that

1. no dirt and no impurities of foreign fluids penetrate the filter,
2. the connection for input and output are correctly connected to the pipe system,
3. the pipe system is connected with the filter; as stress free as possible,
4. the extension to demount and the accessibility to the service elements is quaranted.

Filter with electrical respectively electronic clogging indicators have to be installed according to the unit specific conditions and according to the technical parameters of the corresponding data sheets.

3. Commissioning

Before commissioning the completeness of the filter (filter elements and seals) and the clean ness have to be controlled. Air bleeding of the controlled filter has to be carried out according to the following instructions:

- 1 The positioning pin of the selector shaft has to be located in the middle position
2. Connection of high-pressure hoses M16 according to data sheet 1650 with connections III and IV, if these are equipped with screw couplings, or connection of suitable ventilation lines to the thread G ¼" (BSPP ½") of the above. Connections after unscrewing the screw plugs
3. Provision of an intercepting tank for the discharging medium
4. Connection of the unit volume flow (reduced volume flow; from <10 l/min (2.64 gpm/min)) until bubble-free operating fluid flows out of both air bleeding tubes
5. Disconnection of the unit volume flow
6. Remove the air bleeding tubes and close the air-bleed bore holes or air-bleed connections (air-bleed connections according to data sheet 1651)
7. Connection to the required filter side at the positioning pin of the selector shaft

The positioning pin of the selector shaft shows always in direction to the operating filter side.
The air bleeding has to be done parallel at all filters in the case of paralleling filters.

4. Change of element

The changing of the filter elements is necessary when reaching the unit specific pressure difference respectively reaching the maximum pressure difference given by the clogging indicator. If should is no unit specific definition, the change of the elements should be done at a maximum of $\Delta p = 6 \text{ bar}$ (87 PSI).

This has to be carried out as follows:

1. Switching over the positioning pin from the operating side to the other side
2. At the serviced filter side the connection III or IV has to be opened by connecting a high pressure tube M16 according to data sheet 1650 or should be connected to a suitable air-bleed line if no screw fittings are present. A vessel should be held ready to catch the emerging fluid
3. Unscrew the filter bowl
4. Remove the filter elements
5. Clean the filter bowl
6. Replace the new or the cleaned filter elements
7. Screw the filter bowl back on and tighten it. (tightening torque 80 Nm)
8. Close up any outlets

Now, the serviced filter side is ready for operation.

In general take care of the absolute cleanness during the changing of elements. No dirt respectively no impurities should penetrate the filter. The new elements should be taken out of their packing shortly before they are replaced in the filter housing because of mechanical damage. During the changing of the elements control the availability and quality of the seals. Damaged seals have to be replaced by new ones.

5. Cleaning of the filter element

Filter elements with filter materials such as glass fiber (VG) are not cleanable. They have to be replaced after the dirt retention capacity has been reached. Filter elements with filter material such as wire mesh (G) are cleanable and could be used again.

The cleaning of the filter elements has to be done according to the cleaning specification for Eaton-filter elements (metal), sheet-no. 21070-4 and 39448-4.

6. Pressure difference measuring

In case of filters installed with clogging indicators a permanent measuring of the pressure difference takes place. The indication corresponds to the kind of clogging indicators; either visual or visual-electrical respectively electronic. Additionally the connections III and IV could be installed on the selector shaft to be used for external pressure gauges

7. Change of sealings

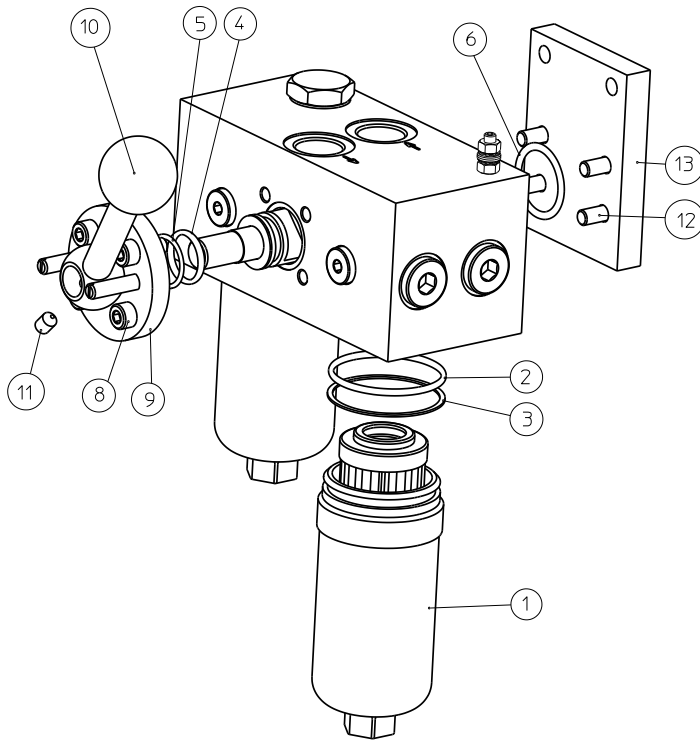

1. Disassemble the filter bowl (item 1). Remove and replace O-ring 54x3 (item 2) and support ring 60x2,6x1 (item 3). Assemble and tighten the filter bowl. (tightening torque 80 Nm (59 lb.-ft.))
2. Loosen the screws (item 8) and remove the cover (item 9) and the lever (item 10/11). Remove and replace the O-ring 23x3 (item 4) and the support ring 28x3.6x1 (item 5). Assemble the cover and lever and tighten the screws. (tightening torque 18-20 Nm (13 to 15 lb.-ft.))
3. Loosen the screws (item 12) and remove the plate (item 13). Remove and replace the O-ring 32.9x3.53 (item 6). Assemble the plate and tighten the screws. (tightening torque 18-20 Nm (13 to 15 lb.-ft.))

8. Service

The service will be performed by

EATON Technologies GmbH
Friedensstr. 41
D-68804 Altlußheim
Germany

phone: +49(0)6205-2094-0
fax: +49(0)6205-2094-40

Special questions about the operation of the filter will also be answered within this area.
Spare parts respectively wearing parts have to be ordered according to the spare part list of the filter-data-sheet.