

PRESSURE FILTER, change-over ball valve
Series DSF 1205-10005 232 PSI

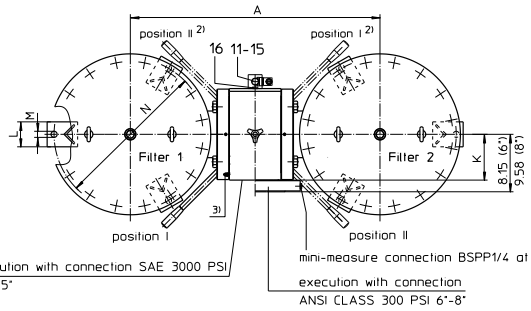

Position I: filter 1 in operation
Position II: filter 2 in operation
Switch lever standard in the front

2) On request: Switch lever backside opposite to inlet and outlet.

Please specify on order!

3) connection for the potential equalization at inlet and outlet resp. filter housing, only for application in the explosive area

execution with connection SAE 3000 PSI 2" - 5"
mini-measure connection BSPP1/4 at inlet and outlet
execution with connection ANSI CLASS 300 PSI 6"-8"

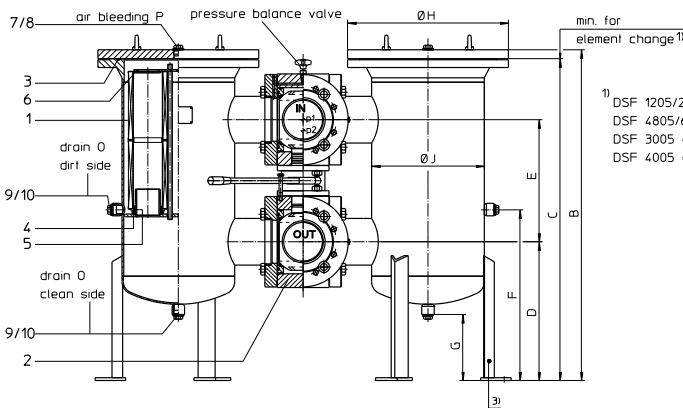

1) DSF 1205/2005/2405/3605 = 20.47 inch
DSF 4805/6005/10005 = 20.47 inch
DSF 3005 = 30.12 inch
DSF 4005 = 40.16 inch

3. Dimensions: inch

type	ANSI	A	B	C	D	E	F	G	H	J	K	L	M	N	O	P	weight lbs.	volume tank
DSF 1205	2"	24.02	39.72	38.78	14.37	6.89	18.11				2.91					1/2 BSPP	440	2x 7 Gal
	2 1/2"	22.04	39.72	38.78	14.37	10.63	18.11	7.28	13.38	8.62	3.54	2.76	.71	12.99		1/2 BSPP	440	2x 7 Gal
	3"	23.03	39.72	38.78	14.76	11.42	18.11				3.93					1 BSPP	440	2x 7 Gal
	4"	24.41	40.31	39.37	15.35	14.37	18.70				5.00					1 BSPP	440	2x 7 Gal
DSF 2005	2 1/2"	24.80	39.80	38.78	14.96	10.63	18.11				3.54					1 BSPP	616	2x 10 Gal
	3"	25.20	39.80	38.78	14.96	11.42	18.11	7.28	15.94	10.75	3.93	2.76	.71	14.96		1 BSPP	616	2x 10 Gal
	4"	26.38	41.18	40.16	15.75	14.37	19.49				5.00					1 BSPP	616	2x 11 Gal
	5"	28.74	42.76	41.73	16.53	15.55	21.06				5.59					1 BSPP	616	2x 12 Gal
DSF 2405	2 1/2"	26.77	41.46	40.35	15.35	10.63	18.90				3.54					1 BSPP	781	2x 15 Gal
	3"	27.56	41.46	40.35	15.75	11.42	18.90	7.28	18.11	12.76	3.93	2.76	.71	17.72		1 BSPP	781	2x 15 Gal
	4"	28.74	42.44	41.34	16.14	14.37	19.88				5.00					1 BSPP	781	2x 16 Gal
	5"	30.31	43.82	42.72	16.73	15.55	21.26				5.59					1 BSPP	781	2x 17 Gal
DSF 3005	2 1/2"	24.80	39.80	38.77	14.96	10.63	18.11				3.54					1 BSPP	682	2x 14 Gal
	3"	25.20	39.80	38.77	14.96	11.42	18.11				3.93					1 BSPP	682	2x 14 Gal
	4"	26.38	41.18	40.15	15.75	14.37	19.49	7.28	15.94	10.75	5.00	2.76	.71	14.96		1 BSPP	682	2x 14.5 Gal
	5"	28.74	42.75	41.73	16.53	15.55	21.06				5.59					1 BSPP	682	2x 15 Gal
DSF 3605	3"	29.92	42.75	41.73	16.53	17.32	21.06	6.89			-					1 BSPP	1276	2x 15 Gal
	4"	30.71	45.35	44.10	18.90	11.42	22.63				3.93	3.54	.87	21.65		1 BSPP	1276	2x 26 Gal
	5"	31.89	45.35	44.10	18.90	14.37	22.63	9.25	22.83	15.98	5.00	3.54	.87	21.65		1 BSPP	1276	2x 26 Gal
	6"	34.25	46.93	45.67	19.69	15.55	24.21				5.59					1 BSPP	1276	2x 27 Gal
DSF 4005	2 1/2"	24.80	49.52	48.50	14.96	10.63	18.11				3.54					1 BSPP	748	2x 17 Gal
	3"	25.20	49.52	48.50	14.96	11.42	18.11	7.28	15.94	10.75	3.93	2.76	.71	14.96		1 BSPP	748	2x 17 Gal
	4"	26.38	50.90	49.88	15.75	14.37	19.49				5.00					1 BSPP	748	2x 17.5 Gal
	5"	28.74	52.48	51.45	16.53	15.55	21.06				5.59					1 BSPP	748	2x 18 Gal
DSF 4805	4"	35.83	47.87	46.46	20.47	14.34	25.00				5.00					1 BSPP	1760	2x 45.5 Gal
	5"	35.83	47.87	46.46	20.47	15.55	25.00	9.25	28.15	20.00	5.59	3.54	.87	25.59		1 BSPP	1760	2x 43.5 Gal
	6"	40.94	48.66	47.24	20.87	17.32	25.79				-					1 BSPP	1760	2x 45 Gal
	8"	42.91	54.17	52.76	22.05	20.47	31.30				-					1 BSPP	1760	2x 52 Gal
DSF 10005	5"	46.10	53.14	51.57	24.80	15.55	30.12				5.59					1 BSPP	2090	2x 94.5 Gal
	6"	49.21	53.14	51.57	24.80	17.32	30.12	11.22	35.83	27.99	-	4.72	.87	35.43		1 BSPP	2090	2x 94.5 Gal
	8"	50.79	58.66	57.09	25.98	20.47	35.63				-					1 BSPP	2090	2x 108 Gal

1. Type index:

1.1. Complete filter: (ordering example)

DSF. 3605. 10VG. 10. E. P. -. FS. B. -. AE

1	2	3	4	5	6	7	8	9	10	11
---	---	---	---	---	---	---	---	---	----	----

- series:
DSF = duplex filter
- nominal size: 1205, 2005, 2405, 3005, 3605, 4005, 4805, 6005, 10005
- filter material and filter fineness:
80 G = 80 µm, 40 G = 40 µm, 25 G = 25 µm, 10 G = 10 µm stainless steel wire mesh,
25 VG = 20 µm_(c), 16 VG = 15 µm_(c), 10 VG = 10 µm_(c), 6 VG = 7 µm_(c), 3 VG = 5 µm_(c), glass fiber
25 API = 20 µm, 10 API = 10 µm glass fiber according to API
25 P = 25 µm, 10 P = 10 µm paper
- resistance of pressure difference for filter element:
10 = Δp 145 PSI
- filter element design:
E = without by-pass valve S = with by-pass valve Δp 29 PSI
- sealing material:
P = Nitrile (NBR) V = Viton (FPM)
- filter element specification:
- = standard
VA = stainless steel
ISO6 = for HFC application, see sheet-no. 31601
- connection:
FS = SAE-flange connection 3000 PSI, only for 2" - 5"
FA 1 = ANSI-flange connection CLASS 300 PSI sealing surface rough grind 1600-3600 µin, only for 6" - 8"
FA 2 = ANSI-flange connection CLASS 300 PSI sealing surface rough grind < 640 µin, only for 6" - 8"
- connection size:

filter-nominal size	DSF 1205	DSF 2005	DSF 2405	DSF 3005	DSF 3605
connection size	8-9-A-B	9-A-B-C	9-A-B-C	9-A-B-C-D	A-B-C-D
filter-nominal size	DSF 4005	DSF 4805	DSF 6005	DSF 10005	
connection size	9-A-B-C	B-C-D-E	B-C-D-E	C-D-E	

8 = 2" 9 = 2 1/2" A = 3" B = 4" C = 5" D = 6" E = 8"

10 filter housing specification:

- = standard
- ISO6 = for HFC application, see sheet-no. 31605

11 clogging indicator or clogging sensor:

- = without
- OP = visual, see sheet-no.1628
- OE = visual-electric, see sheet-no 1628
- AE = visual-electric, see sheet-no.1609
- VS5 = electronic, see sheet-no.1641

1.2. Filter element: (ordering example)

01E. 1201. 10VG. 10. E. P. -

1	2	3	4	5	6	7
---	---	---	---	---	---	---

- series:
01E. = filter element according to company standard
- nominal size: 1201, 2001, 3001, 4001
- 7 see type index-complete filter

2. Accessories:

- measure-and bleeder -connections see sheet-no. 1650
 - evacuation- and bleeder-connections see sheet-no. 1651
 - shut-off valve see sheet-no. 1655
 - SAE-counter flanges see sheet-no. 1652
 - adaptor for ANSI-flange 300 PSI (2"-5") see sheet-no. 1658
 - lifting mechanism see sheet-no. 1661
- Changes of measures and design are subject to alteration!

4. Spare parts:

4.1. Depending on different series:

item	designation	qty.	dimension and article-no. DSF 1205	dimension and article-no. DSF 2005	qty.	dimension and article-no. DSF 2405	dimension and article-no. DSF 3005	qty.	dimension and article-no. DSF 3605	dimension and article-no. DSF 4005	qty.	dimension and article-no. DSF 4805	dimension and article-no. DSF 6005	dimension and article-no. DSF 10005			
1	filter element	2	01E.1201	01E.2001	4	01E.1201	01E.3001	6	01E.1201	01E.4001	8	01E.1201	01E.2001	10	01E.2001		
2	change over UKK	1	2"- 4" ANSI	2 ½"- 5" ANSI	1	2 ½"- 5" ANSI	2 ½"- 6" ANSI	1	3"- 6" ANSI	2 ½"- 5" ANSI	1	4"- 8" ANSI	4"- 8" ANSI	1	5"- 8" ANSI		
3	O-ring	2	225 x 5 308652 (NBR) 311473 (FPM)	275 x 5 307414 (NBR) 310288 (FPM)	2	330 x 5 303080 (NBR) 310275 (FPM)	275 x 5 307414 (NBR) 310288 (FPM)	2	429 x 6 308659 (NBR) 310273 (FPM)	275 x 5 307414 (NBR) 310288 (FPM)	2	516 x 6 301962 (NBR) 311474 (FPM)	516 x 6 301962 (NBR) 311474 (FPM)	2	722 x 8 308145 (NBR) 311805 (FPM)		
4	O-ring	2	85 x 10 304386 (NBR) 304541 (FPM)	125 x 10 304388 (NBR) 306006 (FPM)	4	85 x 10 304386 (NBR) 304541 (FPM)	125 x 10 304388 (NBR) 306006 (FPM)	6	85 x 10 304386 (NBR) 304541 (FPM)	125 x 10 304388 (NBR) 306006 (FPM)	8	85 x 10 304386 (NBR) 304541 (FPM)	125 x 10 304388 (NBR) 306006 (FPM)	6	125 x 10 304388 (NBR) 306006 (FPM)	10	125 x 10 304388 (NBR) 306006 (FPM)
5	O-ring	2	93 x 5 307589 (NBR) 307589 (FPM)	135 x 5 306016 (NBR) 307045 (FPM)	4	93 x 5 307589 (NBR) 307589 (FPM)	135 x 5 306016 (NBR) 307045 (FPM)	6	93 x 5 307589 (NBR) 307589 (FPM)	135 x 5 306016 (NBR) 307045 (FPM)	8	93 x 5 307589 (NBR) 307589 (FPM)	135 x 5 306016 (NBR) 307045 (FPM)	6	135 x 5 306016 (NBR) 307045 (FPM)	10	135 x 5 306016 (NBR) 307045 (FPM)
6	spring	2	Da = 95 304414	Da = 95 304414	2	pressure plate	Da = 95 304414	2	pressure plate	Da = 95 304414	2	pressure plate	pressure plate	2	pressure plate		
7	screw plug	2	½ BSPP 309730	1 BSPP 309732	2				1 BSPP 309732					2	1 ½ BSPP 318556		
8	gasket	2	A 22 x 27 305564	A 33 x 39 308257	2				A 33 x 39 308257					2	A 48 x 55 309764		
9	screw plug	4	1 BSPP 309732	1 BSPP 309732	4				1 BSPP 309732					4	1 ½ BSPP 318556		
10	gasket	4	A 33 x 39 308257	A 33 x 39 308257	4				A 33 x 39 308257					4	A 48 x 55 309764		

4.2. Depending on the series:

item	qty.	designation	dimension	article-no.
11	1	clogging indicator, visual	OP	see sheet-no. 1628
12	1	clogging indicator, visual-electrical	OE	see sheet-no. 1628
13	1	clogging indicator, visual-electrical	AE	see sheet-no. 1609
14	1	clogging sensor, electrical	VS5	see sheet-no. 1641
15	2	O-ring	14 x 2	304342 (NBR) 304722 (FPM)
16	2	screw plug	G ¼	305003

item 16 execution only without clogging indicator or clogging sensor

5. Description:

Duplex filters of the series DSF 1205-10005 are suitable for a working pressure up to 232 PSI.

Pressure peaks can be absorbed with a sufficient margin of safety.

Change-over ball valve between the two filter housings makes it possible to switch from the dirty filter-side to the clean filter-side without interrupting operation. The filters can be installed as suction filter, pressure filter or return-line filter.

The filter element consist of star-shaped, pleated filter material which is supported on the inside by a perforated core tube and is bonded to the end caps with a high-quality adhesive. The flow direction is from outside to the inside.

For cleaning (see special leaflet 21070-4 and 34448-4) the mesh element respectively to change the glass fiber element remove the cover and take out the element.

Filter finer than 40 µm should use throw-away elements made of paper or glass fiber. Filter elements as fine as 5 µm(c) are available; finer filter elements on request.

Eaton filter elements are known as elements with a high intrinsic stability and an excellent filtration capability, a high dirt-retaining capacity and a long service life.

Eaton filter are suitable for all petroleum based fluids, HW-emulsions, most synthetic hydraulic fluids and lubrication oils.

Ship classifications available upon request.

6. Technical data:

temperature range:	+14°F to +212°F
operating medium:	mineral oil, other media on request
max. operating pressure:	232 PSI
test pressure:	332 PSI
connection system:	SAE-flange 3000 PSI or ANSI-flange B16.5 CLASS 300 PSI
housing material:	C-steel
sealing material:	Nitrile (NBR) or Viton (FPM), other materials on request
installation position:	vertical
mini-measuring connection:	½ BSPP

Classified under the Pressure Equipment Directive 2014/68/EU for mineral oil (fluid group 2), Article 4, Para. 3.

Classified under ATEX Directive 2014/34/EU according to specific application (see questionnaire sheet-no. 34279-4).

7. Symbols:

without indicator

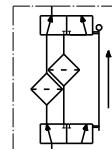

with visual - electric indicator AE 50 and AE 62

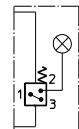

with visual indicator OP

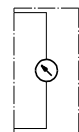

with electronic clogging sensor VS5

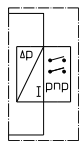

with electric indicator AE 30 and AE 40

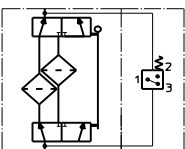

with visual - electric indicator AE 70 and AE 80

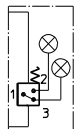

with visual - electric indicator OE

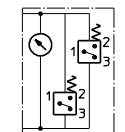

8. Pressure drop flow curves:

Precise flow rates see 'Interactive Product Specifier', respectively Δp-curves; depending on filter fineness and viscosity.

9. Test methods:

ISO 2941	Verification of collapse/burst resistance
ISO 2942	Verification of fabrication integrity
ISO 2943	Verification of material compatibility with fluids
ISO 3723	Method for end load test
ISO 3724	Verification of flow fatigue characteristics
ISO 3968	Evaluation of pressure drop versus flow characteristics
ISO 16889	Multi-pass method for evaluating filtration performance