

PRESSURE FILTER, change-over
Series DSF 1201-10001 DN 50-250 PN 16

Sheet No.
2133 P

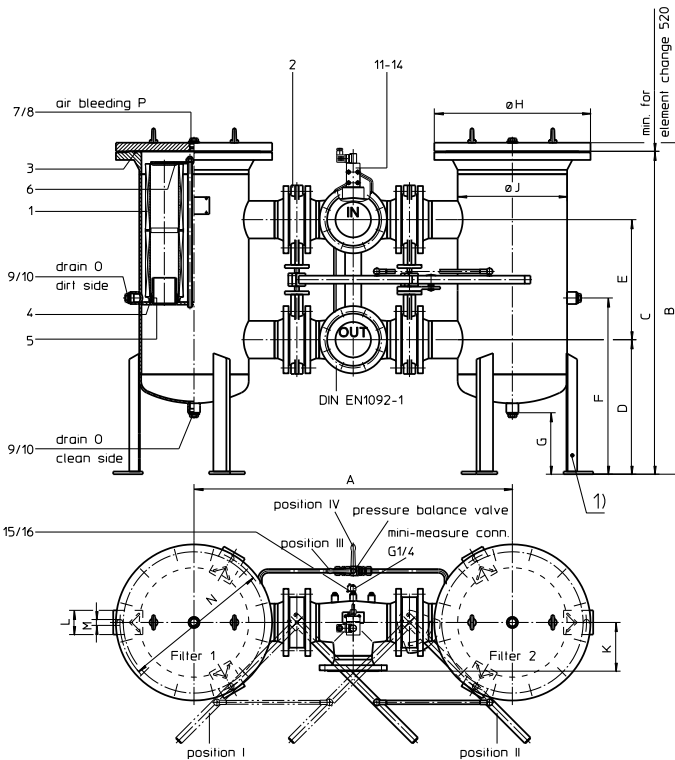

1) connection for the potential equalization, only for application in the explosive area

with pressure balance valve:
 Pos III: valve open
 Pos IV: valve closed

Connection standard as in drawing.
 On request: inlet - on top and backside
 outlet - bottom and backside

Please specify on order!

Pos. I: filter 1 in operation
 Pos. II: filter 2 in operation

3. Dimensions:

type	connection DN	A	B	C	D	E	F	G	H	J	K	L	M	N	O	P	weight kg	volume tank				
DSF 1201	50	796	1035	1015	395	330	490	183	340	219	111	70	18	330	G1	G ½	200	2x 26,0 l				
	65	822				347					123											
	80	862				400					138											
	100	914				421					159											
DSF 2001	65	902	1100	1075	425	347	550	186	405	273	123	70	18	380	G1	G1	280	2x 44,0 l				
	80	942				400					138											
	100	984				421					159											
	125	1032				446					181											
DSF 2401	65	952	1115	1085	425	347	540	183	460	324	123	70	18	450	G1	G1	355	2x 63,0 l				
	80	992				400					138											
	100	1034				421					159											
	125	1082				446					181											
DSF 3601	65	1092	1185	1155	445	492	610				200	90	22	550	G1	G1	580	2x 109,0 l				
	80	1144				400					138											
	100	1182				421					159											
	125	1212				446					181											
DSF 4001	65	902	1596	1570	425	347	550	186	405	273	123	70	18	380	G1	G1	340	2x 70,0 l				
	80	942				400					138											
	100	984				421					159											
	125	1032				446					181											
DSF 4801	100	1274	1240	1200	520	421	655				159	90	22	650	G1	G1	800	2x 171,0 l				
	125	1322				446					181							2x 171,0 l				
	150	1352				1290					1250							530	492	705	200	2x 180,0 l
DSF 6001	200	1440	1390	1350	560	543	765				242	120	22	900	G1 ½	G1 ½	950	2x 199,0 l				
	125	1592				1340					1300							620	446	755	181	2x 355,0 l
DSF 10001	150	1632	1390	1350	630	492	805	283	910	711	200	120	22	900	G1 ½	G1 ½	950	2x 374,0 l				
	200	1700				1490					1450							650	543	870	242	2x 411,0 l
	250	1800				1620					1580							680	618	1000	288	2x 460,0 l

1. Type index:

1.1. Complete filter: (ordering example)

DSF. 3601. 10VG. 10. E. P. -. FD1. B. -. AE

1	2	3	4	5	6	7	8	9	10	11
---	---	---	---	---	---	---	---	---	----	----

- 1 series:
DSF = duplex filter
- 2 nominal size: 1201, 2001, 2401, 3601, 4001, 4801, 6001, 10001
- 3 filter material and filter fineness:
80 G = 80 µm, 40 G = 40 µm, 25 G = 25 µm stainless steel wire mesh,
25 VG = 20 µm_(c), 16 VG = 15 µm_(c), 10 VG = 10 µm_(c), 6 VG = 7 µm_(c), 3 VG = 5 µm_(c) glass fibre
25 API = 20 µm, 10 API = 10 µm glass fibre according to API
10 P = 10 µm paper
- 4 resistance of pressure difference for filter element:
10 = Δp 10 bar
- 5 filter element design:
E = without by-pass valve
S = with by-pass valve Δp 2,0 bar
- 6 sealing material:
P = Nitrile (NBR)
V = Viton (FPM)
- 7 filter element specification:
- = standard
VA = stainless steel
IS06 = for HFC application, see sheet-no. 31601
- 8 process connection:
FD1 = flange connection DIN EN1092-1, design B1
FD2 = flange connection DIN EN1092-1, design B2
- 9 process connection size:

DN	filter nominal size									
8 = 50	1201									
9 = 65	1201	2001	2401		4001					
A = 80	1201	2001	2401	3601	4001					
B = 100	1201	2001	2401	3601	4001	4801	6001			
C = 125		2001	2401	3601	4001	4801	6001	10001		
D = 150			2401	3601		4801	6001	10001		
E = 200						4801	6001	10001		
F = 250								10001		

- 10 filter housing specification:
- = standard
IS06 = for HFC application, see sheet-no. 31605
- 11 clogging indicator or clogging sensor:
- = without
OP = visual, see sheet-no.1628; OE = visual-electric, see sheet-no 1628;
AE = visual-electric, see sheet-no.1609; VS5 = electronic, see sheet-no.1641

1.2. Filter element: (ordering example)

01E. 1201. 10VG. 10. E. P. -

1	2	3	4	5	6	7
---	---	---	---	---	---	---

- 1 series:
01E. = filter element according to company standard
- 2 nominal size: 1201, 2001, 4001
- 3 - 7 see type index-complete filter

2. Accessories:

- measure-and bleeder -connections, see sheet-no. 1650
- evacuation- and bleeder-connections, see sheet-no. 1651
- counter flanges, see sheet-no. 1653
- shut-off valve, see sheet-no. 1655
- lifting mechanism, see sheet-no. 1661

Changes of measures and design are subject to alteration!



Friedenstrasse 41, 68804 Altlusheim, Germany

phone +49 (0)6205 - 2094-0
 fax +49 (0)6205 - 2094-40

e-mail filtration@eaton.com
 url www.eaton.com/filtration

4. Spare parts:

4.1. Depending on different series:

item	designation	qty.	dimension and article-no. DSF 1201	dimension and article-no. DSF 2001	qty.	dimension and article-no. DSF 2401	qty.	dimension and article-no. DSF 3601	qty.	dimension and article-no. DSF 4001	qty.	dimension and article-no. DSF 4801	qty.	dimension and article-no. DSF 6001	qty.	dimension and article-no. DSF 10001
1	filter element	2	01E.1201	01E.2001	4	01E.1201	6	01E.1201	2	01E.4001	8	01E.1201	6	01E.2001	10	01E.2001
2	stop flap ¹⁾	4	DN 50-100	DN 65-125	4	DN 65-150	4	DN 80-150	4	DN 65-125	4	DN 100-200	4	DN 100-200	4	DN 125-250
3	O-ring	2	225 x 5 308652 (NBR) 311473 (FPM)	275 x 5 307414 (NBR) 310288 (FPM)	2	330 x 5 303080 (NBR) 310275 (FPM)	2	429 x 6 308659 (NBR) 310273 (FPM)	2	275 x 5 307414 (NBR) 310288 (FPM)	2	516 x 6 301962 (NBR) 311474 (FPM)	2	516 x 6 301962 (NBR) 311474 (FPM)	2	722 x 8 308145 (NBR) 311805 (FPM)
4	O-ring	2	85 x 10 304386 (NBR) 304541 (FPM)	125 x 10 304388 (NBR) 306006 (FPM)	4	85 x 10 304386 (NBR) 304541 (FPM)	6	85 x 10 304386 (NBR) 304541 (FPM)	2	125 x 10 304388 (NBR) 306006 (FPM)	8	85 x 10 304386 (NBR) 304541 (FPM)	6	125 x 10 304388 (NBR) 306006 (FPM)	10	125 x 10 304388 (NBR) 306006 (FPM)
5	O-ring	2	93 x 5 307588 (NBR) 307589 (FPM)	135 x 5 306016 (NBR) 307045 (FPM)	4	93 x 5 307588 (NBR) 307589 (FPM)	6	93 x 5 307588 (NBR) 307589 (FPM)	2	135 x 5 306016 (NBR) 307045 (FPM)	8	93 x 5 307588 (NBR) 307589 (FPM)	6	135 x 5 306016 (NBR) 307045 (FPM)	10	135 x 5 306016 (NBR) 307045 (FPM)
6	spring	2	Da = 95 304414		2	pressure plate		2	Da = 95 304414		2	pressure plate				
7	screw plug	2	G ½ 309730	G 1 309732	2	G1 309732				2	G 1 ½ 318556					
8	gasket	2	A 22 x 27 305564	A 33 x 39 308257	2	A 33 x 39 308257				2	A 48 x 55 309764					
9	screw plug	4	G1 309732	G1 309732	4	G1 309732				4	G 1 ½ 318556					
10	gasket	4	A 33 x 39 308257	A 33 x 39 308257	4	A 33 x 39 308257				4	A 48 x 55 309764					

¹⁾ dimension of stop flap = connection size

4.2. Depending on the series:

item	qty.	designation	dimension	article-no.
11	1	clogging indicator, visual	OP	see sheet-no. 1628
12	1	clogging indicator, visual-electric	OE	see sheet-no. 1628
13	1	clogging indicator, visual-electric	AE	see sheet-no. 1609
14	1	clogging sensor, electronic	VS5	see sheet-no. 1641
15	2	gasket	A 14 x 18	306330
16	2	screw plug	G ¼	309734

5. Description:

Duplex filters of the series DSF 1201-10001 are suitable for a working pressure up to 16 bar.

Pressure peaks can be absorbed with a sufficient margin of safety.

Four mechanically connected change-over flaps enabling the change-over without service-interruption from the clean to the dirty filter-side.

The filters can be installed as suction filter, pressure filter or return-line filter.

The filter element consist of star-shaped, pleated filter material which is supported on the inside by a perforated core tube and is bonded to the end caps with a high-quality adhesive. The flow direction is from outside to the inside.

Filter finer than 40 µm should use throw-away elements made of paper or glass fibre. Filter elements as fine as 5 µm_(c) are available; finer filter elements on request.

Eaton filter elements are known as elements with a high intrinsic stability and an excellent filtration capability, a high dirt-retaining capacity and a long service life.

Eaton filter are suitable for all petroleum based fluids, HW-emulsions, most synthetic hydraulic fluids and lubrication oils.

Ship classifications available upon request.

6. Technical data:

operating temperature:	- 10°C to + 100°C
operating medium:	mineral oil, other media on request
max. operating pressure:	16 bar
test pressure:	23 bar
connection system:	flange connection DIN EN1092-1, 16 bar
housing material:	C-steel
sealing material:	Nitrile (NBR) or Viton (FPM), other materials on request
installation position:	vertical
mini-measuring connection:	G ¼

Classified under the Pressure Equipment Directive 2014/68/EU for mineral oil (fluid group 2), Article 4, Para. 3.

Classified under ATEX Directive 2014/34/EU according to specific application (see questionnaire sheet-no. 34279-4).

7. Symbols:

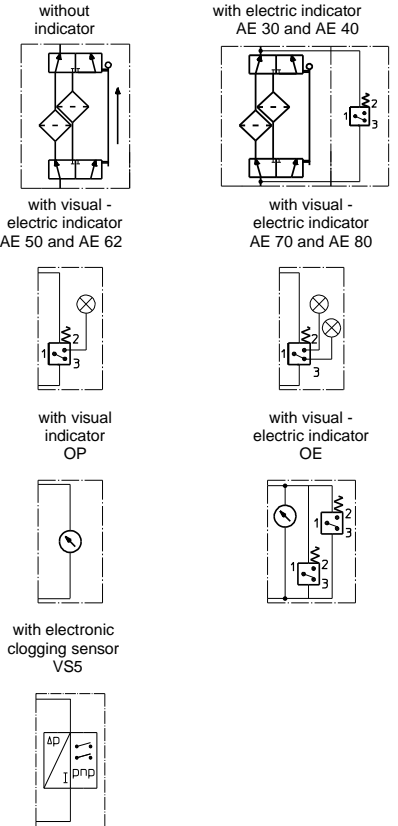

8. Pressure drop flow curves:

Precise flow rates see 'Interactive Product Specifier', respectively Δp-curves; depending on filter fineness and viscosity.

9. Test methods:

Filter elements are tested according to the following ISO standards:

ISO 2941	Verification of collapse/burst resistance
ISO 2942	Verification of fabrication integrity
ISO 2943	Verification of material compatibility with fluids
ISO 3723	Method for end load test
ISO 3724	Verification of flow fatigue characteristics
ISO 3968	Evaluation of pressure drop versus flow characteristics
ISO 16889	Multi-pass method for evaluating filtration performance